

TAP 1/2" - 13 UNC
1.5" DEEP
CLASS 3 R.H.

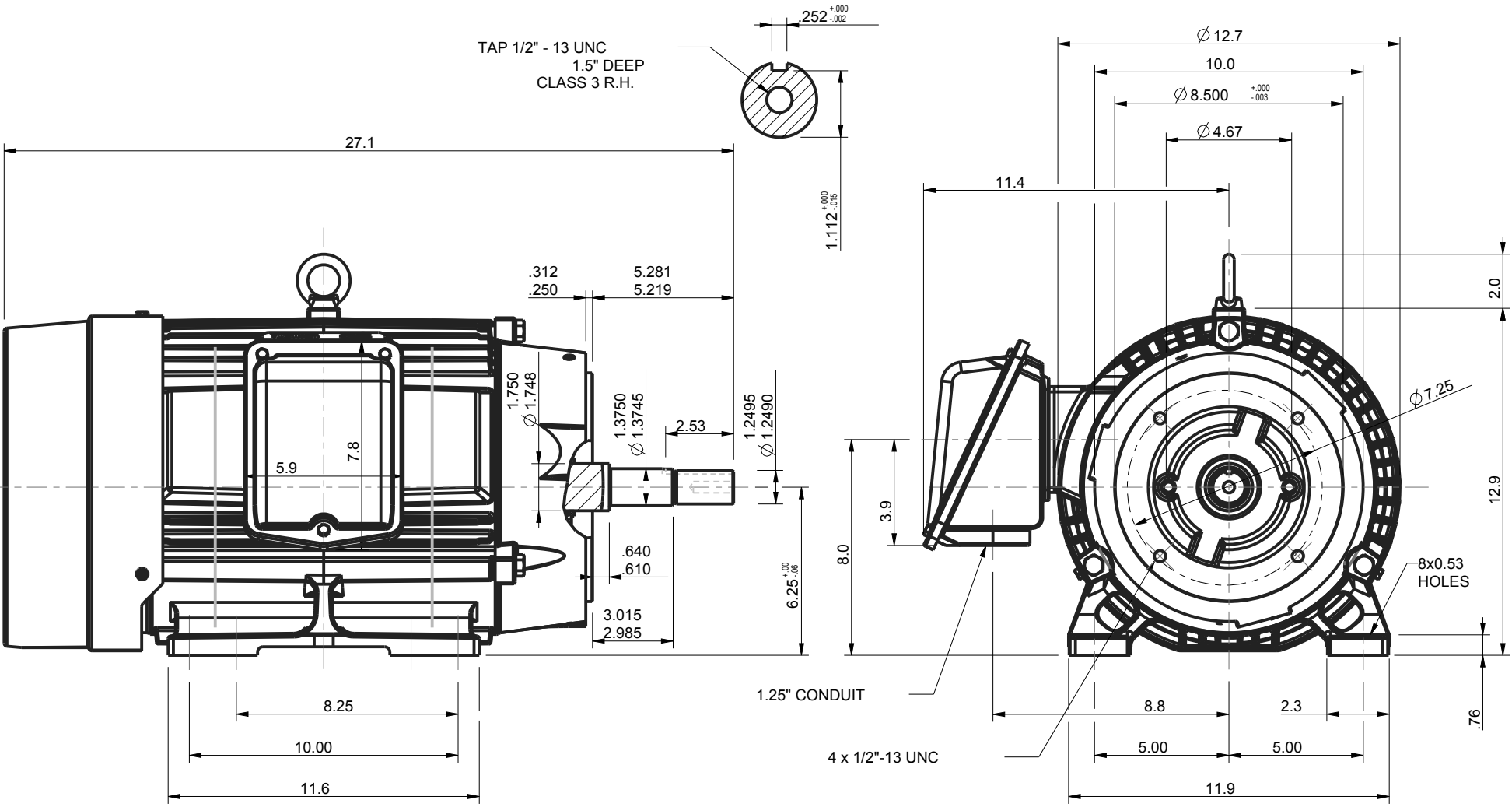

UNITS: INCHES

ROTATION FROM NDE

CCW
 CW

NOTES:
 1. MAIN CONDUIT BOX MAY BE ROTATED IN 90° INCREMENTS
 2. STANDARD PRODUCT USES BI-DIRECTIONAL FAN. OPPOSITE ROTATION AVAILABLE ONLY BY CONNECTION CHANGE.
 3. KEY DIMENSIONS EQUAL 0.250"x 0.250"x 2.53" (MOTOR SUPPLIED WITH KEY)

TOSHIBA RESERVES THE RIGHT TO MAKE CHANGES OF TECHNICAL IMPROVEMENT AND THE DATA MAY CHANGE WITHOUT NOTICE PRELIMINARY

DO NOT USE FOR CONSTRUCTION, INSTALLATION, OR APPLICATION PURPOSES UNLESS THE DRAWING IS MARKED AS CERTIFIED CERTIFIED

TOSHIBA
 www.toshiba.com/tic
 TOSHIBA INTERNATIONAL CORPORATION

SEVERE DUTY
EQP **SD**

TOTALLY ENCLOSED FAN COOLED
 HORIZONTAL FOOT MOUNTED
 3 PHASE INDUCTION MOTOR
 254JM/256JM F1 ASSEMBLY

DRAWING #: MDSL108-04
 REV. DATE: 05/10/18 REV. #: 4 PER.: M. O'DOWD
 REV. DESCIP.: UPDATED TITLE BLOCK, NOTES, &
 DIMENSIONS



Issued Date	9/24/2019	Transmit #	
Issued By	dschoeck	Issued Rev	

TYPICAL MOTOR PERFORMANCE DATA

Model: 0106SDJC41M-P

HP	kW	Pole	FL RPM	Frame	Voltage	Hz	Phase	FL Amps
10	7.5	6	1170	256JM	575	60	3	10.8
Enclosure	IP	Ins. Class	S.F.	Duty	NEMA Nom. Eff.	NEMA Design	kVA Code	Ambient (°C)
TEFC	55	F	1.15	CONT	91	B	G	40 C

Load	HP	kW	Amperes	Efficiency (%)	Power Factor (%)
Full Load	10	7.5	10.8	91.2	80.2
¾ Load	7.50	5.6	7.8	91.1	76.0
½ Load	5.00	3.7	6.1	89.5	66.3
¼ Load	2.50	1.9	4.8	82.6	46.4
No Load			4.3		5.4
Locked Rotor			62		50.1

Torque				Rotor wk ² Inertia (lb-ft ²)
Full Load (lb-ft)	Locked Rotor (% FLT)	Pull Up (% FLT)	Break Down (% FLT)	
44.9	255	250	285	2.65

Safe Stall Time(s)		Sound Pressure dB(A) @ 1M	Bearings*		Approx. Motor Weight (lbs)
Cold	Hot		DE	NDE	
35	15	-	6309ZZC3	6309ZZC3	0

*Bearings are the only recommended spare part(s).

Motor Options:
Mounting:Footed,Shaft:JM Shaft

Customer	
Customer PO	
Sales Order	
Project #	

Tag:

All characteristics are average expected values.

TOSHIBA INTERNATIONAL CORPORATION · HOUSTON, TEXAS U.S.A.

Engineering	garce	Doc. Written By	D. Suarez	Doc.# / Rev	MPCF-1119 / 1
Engr. Date	8/21/2015	Doc. Approved By	M. Campbell	Doc. Issued	9/20/2019



Issued Date	9/24/2019	Transmit #	
Issued By	dschoeck	Issued Rev	

SPEED TORQUE/CURRENT CURVE

Model: 0106SDJC41M-P

HP	kW	Pole	FL RPM	Frame	Voltage	Hz	Phase	FL Amps
10	7.5	6	1170	256JM	575	60	3	10.8
Enclosure	IP	Ins. Class	S.F.	Duty	NEMA Nom. Eff.	NEMA Design	kVA Code	Ambient (°C)
TEFC	55	F	1.15	CONT	91	B	G	40 C
Locked Rotor Amps	Rotor wk ² Inertia (lb-ft ²)	Torque						
		Full Load (lb-ft)	Locked Rotor (%)	Pull Up (%)	Break Down (%)			
62	2.65	44.9	255	250	285			

Design Values

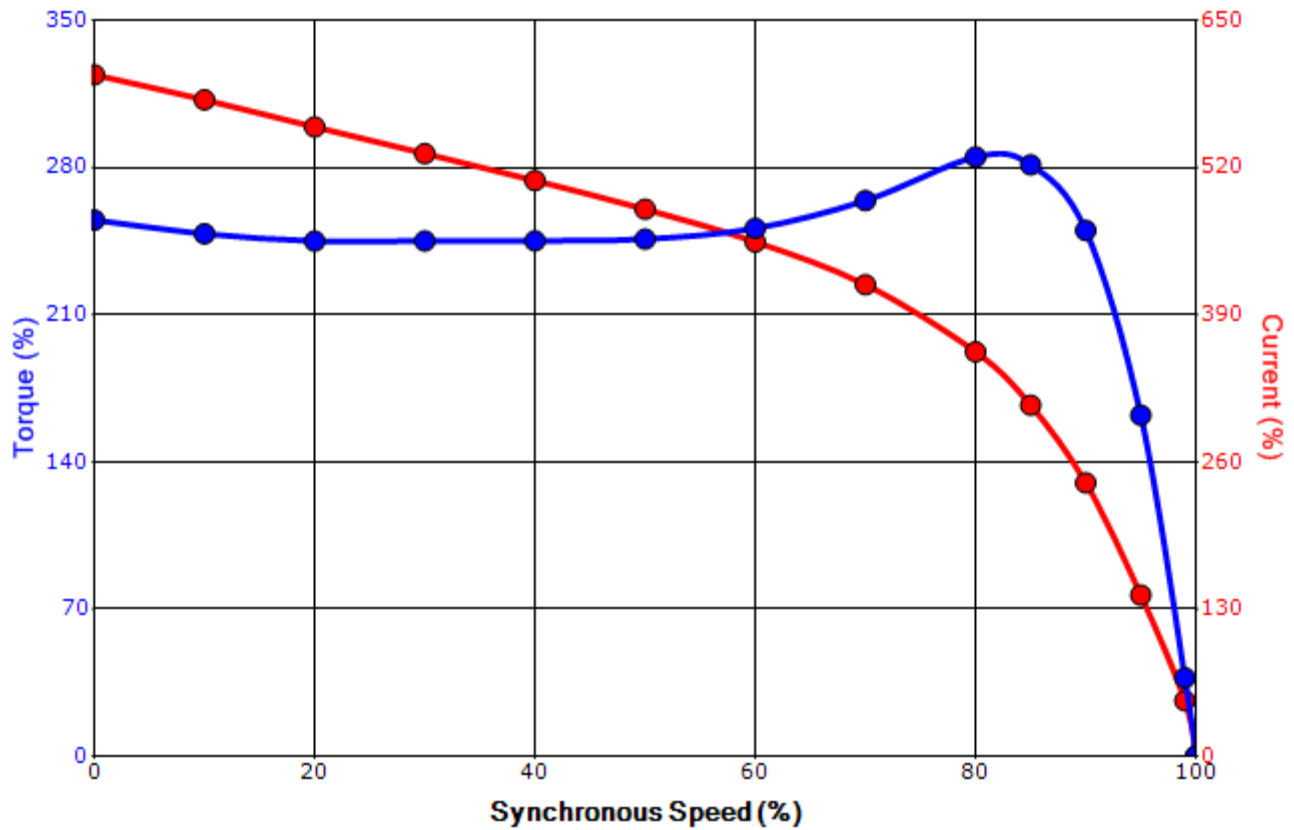

Customer		wk ² Load Inertia (lb-ft ²)	-
Customer PO		Load Type	-
Sales Order		Voltage (%)	100
Project #		Accel. Time	-

Tag:

All characteristics are average expected values.

TOSHIBA INTERNATIONAL CORPORATION · HOUSTON, TEXAS U.S.A.

Engineering	garce	Doc. Written By	D. Suarez	Doc.# / Rev	MPCF-1121/1
Engr. Date	8/21/2015	Doc. Approved By	M. Campbell	Doc. Issued	9/20/2019

Motor Connection Diagrams
6 Leads

Across the Line Starting / Run - Delta:



Alternate Starting Connection - Wye:



Switch L1 and L2 to reverse rotation