

PRODUCT INFORMATION PACKET

Model No: 110047.00

Catalog No: 110047.00

General Purpose Motor, 0.75 HP, 3 Ph, 60 Hz, 208-230/460 V, 1800 RPM, 56C Frame, TEFC



Regal and are trademarks of Regal Rexnord Corporation or one of its affiliated companies.
©2022 Regal Rexnord Corporation, All Rights Reserved. MC017097E

Nameplate Specifications

Output HP	0.75 Hp	Output KW	0.56 kW
Frequency	60 Hz	Voltage	208-230/460 V
Current	2.8/1.4 A	Speed	1725 rpm
Service Factor	1.15	Phase	3
Efficiency	77 %	Power Factor	65
Duty	Continuous	Insulation Class	B
Design Code	B	KVA Code	K
Frame	56C	Enclosure	Totally Enclosed Fan Cooled
Thermal Protection	No Protection	Ambient Temperature	40 °C
Drive End Bearing Size	6203	Opp Drive End Bearing Size	6203
UL	Recognized	CSA	Y
CE	N	IP Code	54
Number of Speeds	1		

Technical Specifications

Electrical Type	Squirrel Cage Induction Run	Starting Method	Across The Line
Poles	4	Rotation	Reversible
Resistance Main	26.24 Ohms	Mounting	Round
Motor Orientation	Horizontal	Drive End Bearing	Ball
Opp Drive End Bearing	Ball	Frame Material	Rolled Steel
Shaft Type	NEMA 56	Overall Length	10.48 in
Frame Length	5.00 in	Shaft Diameter	0.625 in
Shaft Extension	1.88 in	Assembly/Box Mounting	F1 ONLY
Outline Drawing	028776-500	Connection Drawing	005010.01

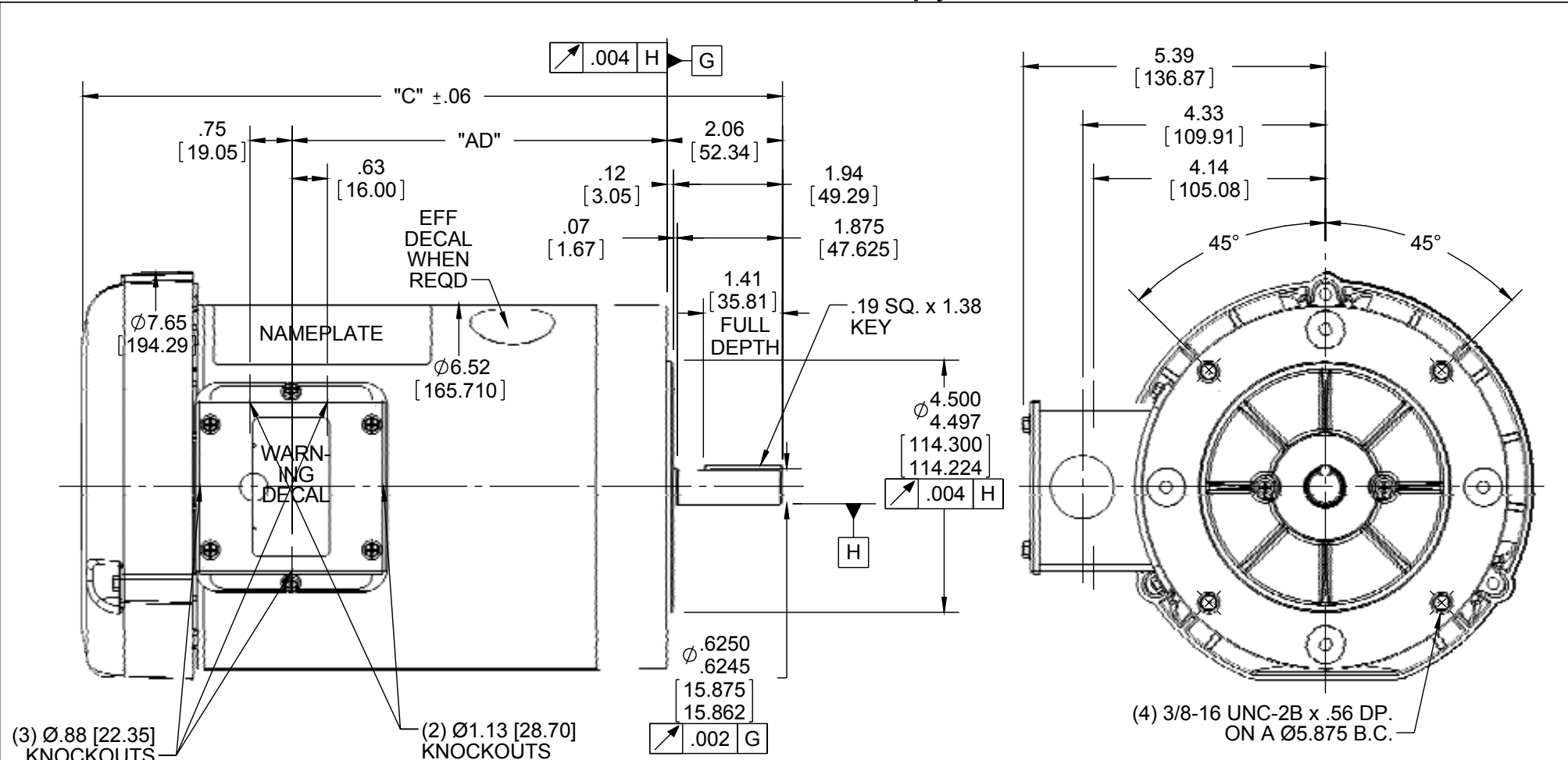

NOTE:
1) GASKETS THROUGHOUT

ORACLE REV
004

DASH NO.	"C"	"AD"
450	9.98	4.19
500	10.48	4.69
550	10.98	5.19
600	11.48	5.69
625	11.73	5.94

DASH NO.	"C"	"AD"
650	11.98	6.19
675	12.23	6.44
700	12.48	6.69
750	12.98	7.19
800	13.48	7.69

DRAWING REVISION E
ECO ECO-0092098
ECO DESCRIPTION
ADDED #450 (114176)
COPYRIGHT REGAL BELOIT AMERICA, INC. ALL RIGHTS RESERVED. PROPRIETARY AND CONFIDENTIAL INFORMATION - THIS DOCUMENT IS THE PROPERTY OF REGAL BELOIT AMERICA, INC. ("OWNER") AND CONTAINS OWNER'S PROPRIETARY INFORMATION. ANY PERSON, CORPORATION OR OTHER FIRM RECEIVING IT IS DEEMED, BY RECEIVING IT, TO AGREE THAT IT, AND/OR ANY PART OF IT, SHALL NOT BE DISCLOSED TO ANY PERSON, CORPORATION OR OTHER ENTITY, DUPLICATED, AND/OR USED, EXCEPT AS EXPRESSLY APPROVED IN WRITING IN ADVANCE BY OWNER. THIS DOCUMENT SHALL BE RETURNED TO OWNER UPON REQUEST. IT MAY BE SUBJECT TO CERTAIN RESTRICTIONS UNDER APPLICABLE EXPORT CONTROL LAWS AND REGULATIONS.

TOLERANCES UNLESS OTHERWISE SPECIFIED:
DEC. INCH mm ANGLE
.X ±0.1 [±2.5] ±0.5°
.XX ±0.01 [±0.25]
.XXX ±0.005 [±0.127]
.XXXX ±0.0005 [±0.0127]
REMOVE BURRS & BREAK SHARP EDGES: .003/.015 [.076/.381] X 45°
CORNER FILLETS: R.02 [.51]
MACHINED SURFACES: 125/3.2 INCH/mm
mm SHOWN IN [BRACKETS]

DRAWN BY KMM
DATE 08/01/07
APPROVED BY
DATE
REFERENCE
THIRD ANGLE PROJECTION

REGAL™ Regal Beloit America, Inc.

OUTLINE
56C FRAME TEFC - "C" FACE

SIZE A	DRAWING NUMBER 028776	PROCESS/FINISH GENERAL PURPOSE	SHEET 1 OF 1
------------------	---------------------------------	-----------------------------------	-----------------

005010-01

VIEW FROM OUTSIDE OF MOTOR AT SWITCH END.



VOLTAGE	L1	L2	L3	JOIN & INSULATE
HIGH	T1	T2	T3	(T4,T7) (T5,T8) (T6,T9)
LOW	T1,T7	T2,T8	T3,T9	T4,T5,T6

				TOLERANCES UNLESS SPECIFIED		REGAL ™ Regal Beloit America, Inc.		DRAWN RDW 04/12/02				
				DEC.	INCHES			CHK				
				.X	±.1			APPD				
				.XX	±.01			SCALE 1=1				
				.XXX	±.005	TITLE		REF FIG.2-51				
A	UPDATED TO REGAL LOGO			SAJ	06/26/15	AJY	.XXXX	±.0005	MAT'L. DECAL - 004014	FMF		
NO.	REVISION			BY & DATE	CHK	ANG	±1/2"	FINISH	PREV			
THIS DRAWING IN DESIGN AND DETAIL IS OUR PROPERTY AND MUST NOT BE USED EXCEPT IN CONNECTION WITH OUR WORK ALL RIGHTS OF DESIGN AND INVENTION ARE RESERVED THIS IS AN ELECTRONICALLY GENERATED DOCUMENT - DO NOT SCALE THIS PRINT				RFP	04/12/02		CAD FILE	00501001		SIZE	DRAWING NO.	REV.
				DIST	BRF-NLV			A	005010-01		A	

P.O. BOX 8003
 WAUSAU, WI 54401-8003
 PH. 715-675-3311



DATA VOLTS: 460

CERTIFICATION DATA SHEET

CONN. DIAGRAM: 005010.01
 OUTLINE: 028776-500
 WINDING: T634188

CAT #: 110047.00

FR 3

TYPICAL MOTOR PERFORMANCE DATA

HP	KW	SYNC RPM	FL RPM	FRAME	ENCLOSURE	TYPE	KVA CODE	DESIGN
0.75	0.56	1800	1745	56C	TEFC	TFR	K	B

PH	HZ	VOLTS	AMPS	START TYPE	DUTY	INSL	S.F.	AMB	ELEV.
3	60	208-230/460	2.8/1.4	ACROSS THE LINE	CONT	B	1.15	40	3300

F.L. EFF	77.3	3/4 LD EFF	75.6	1/2 LD EFF	70.3	GTD EFF	0.0	ELECT. TYPE	SQ CAGE IND RUN
F.L. PF	64.6	3/4 LD PF	54.7	1/2 LD PF	42.5				

F.L. TORQUE	574 LB-FT	LR AMPS @ 460 V	8.1	L.R. TORQUE	1,691 LB-FT 295%	B.D. TORQUE	2,137 LB-FT 372%	F.L. RISE (°C)	60

PRESSURE @ 3	52 dBA	POWER	61 dBA	ROTOR WK ²	0.06 LB-FT ²	MAX. LOAD WK ²	0.1 LB-FT ²	SAFE STALL TIME	10 SEC.	STARTS/HOUR	0	MOTOR WGT	0 LB.

***** SUPPLEMENTAL INFORMATION *****

DE BRACKET TYPE	ODE BRACKET TYPE	MOUNT TYPE	MOTOR ORIENTATION	SEVERE DUTY	HAZARDOUS LOCATION	DRIP COVER	SCREENS	PAINT
C-FACE	STANDARD	ROUND	HORIZONTAL	NO	NONE	NO	NONE	JE - LEESON (ENAM)

BEARINGS		GREASE	SHAFT TYPE	SPECIAL DE	SPECIAL ODE	SHAFT MATERIAL	FRAME MATERIAL
DE	ODE						
BALL	BALL	POLYREX EM	STANDARD 56	NONE	NONE	1144 STRESSPROOF (C-223)	ROLLED STEEL
6203	6203						

THERMOSTATS	PROTECTORS	WDG RTD's	BRG RTD's	THERMISTORS	CONTROL	SPACE HEATERS
NONE	NOT	NONE	NONE	NONE	FALSE	NA

R1 (ohms/ph)	R2 (ohms/ph)	X1 (ohms/ph)	X2 (ohms/ph)	Xm (ohms/ph)	VIBRATION (in/sec)	FLOAT
0	0	0	0	0	0.150	ODE

* N O T E S *		INVERTER TORQUE: NONE INV. HP SPEED RANGE: NONE ENCODER: NONE NONE NONE NONE PPR

DATE: 2/2/2018	BRAKE: NONE NONE NONE FT-LB: NA VOLTAGE: NONE HZ: UL: Y-(LEESON UL REC)
----------------	---

Data Sheet

Date: 2/2/2018

110047.00



Data @ 460 V

Motor Load Data

Load	0%	25%	50%	75%	100%	115%	125%	LR
Current (Amps)	1.10	1.14	1.19	1.28	1.40	1.50	1.56	8.1
Torque (ft-lb)	0.00	144	287	431	574	660	718	1,691
RPM	1800	1787	1774	1760	1745	1,735	1730	0
Efficiency (%)		54.9	70.3	75.6	77.3	78.7	79.3	
P.F. (%)	13.0	28.6	42.5	54.7	64.6	67.8	70.1	0.0

Motor Speed Data

	LR	Pull-Up	BD	Rated	Idle
Speed (RPM)	0	300	1550	1745	1800
Current (Amps)	8.1	8.0	4.9	1.40	1.10
Torque (ft-lb)	1,691	1,643	2,137	574	0.00

Information Block				
HP	0.8			
Sync. RPM	1800			
Frame	140			
Enclosure	TEFC			
Construction	TFR			
Voltage	208-230/460 V			
Frequency	60 Hz			
Design	B			
LR Code letter	K			
Service Factor	1.15			
Temp Rise @ FL	60 °C			
Duty	CONT			
Ambient	40 °C			
Elevation	1,000 feet			
Rotor/Shaft wk ²	0.06 Lb-Ft ²			
Ref Wdg	T634188 FR			
Sound Pressure @ 1M	52 dBA			
VFD Rating	NONE			
Outline Dwg	028776-500			
Conn. Diag	005010.01			
Additional Specifications:				
0				
0				
EQUIV CKT (OHMS / PHASE)				
R1	R2	X1	X2	Xm
0.0000	0.0000	0.0000	0.0000	0.0000

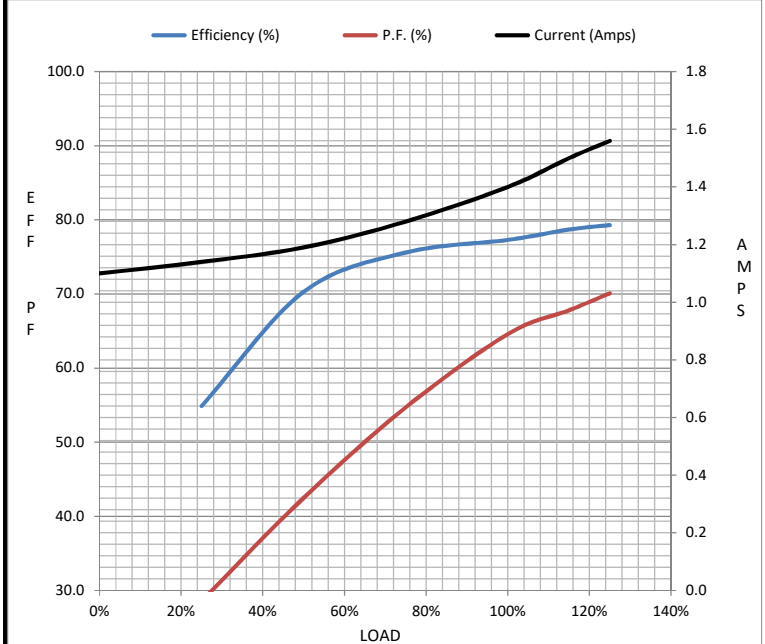

Speed - Torque Curve

