

NEMA MOUNTING HOLES  
 DRILL THRU  
 NEMA HOLE SIZE  
 Ø21 (Ø13/16")  
 12 PLACES

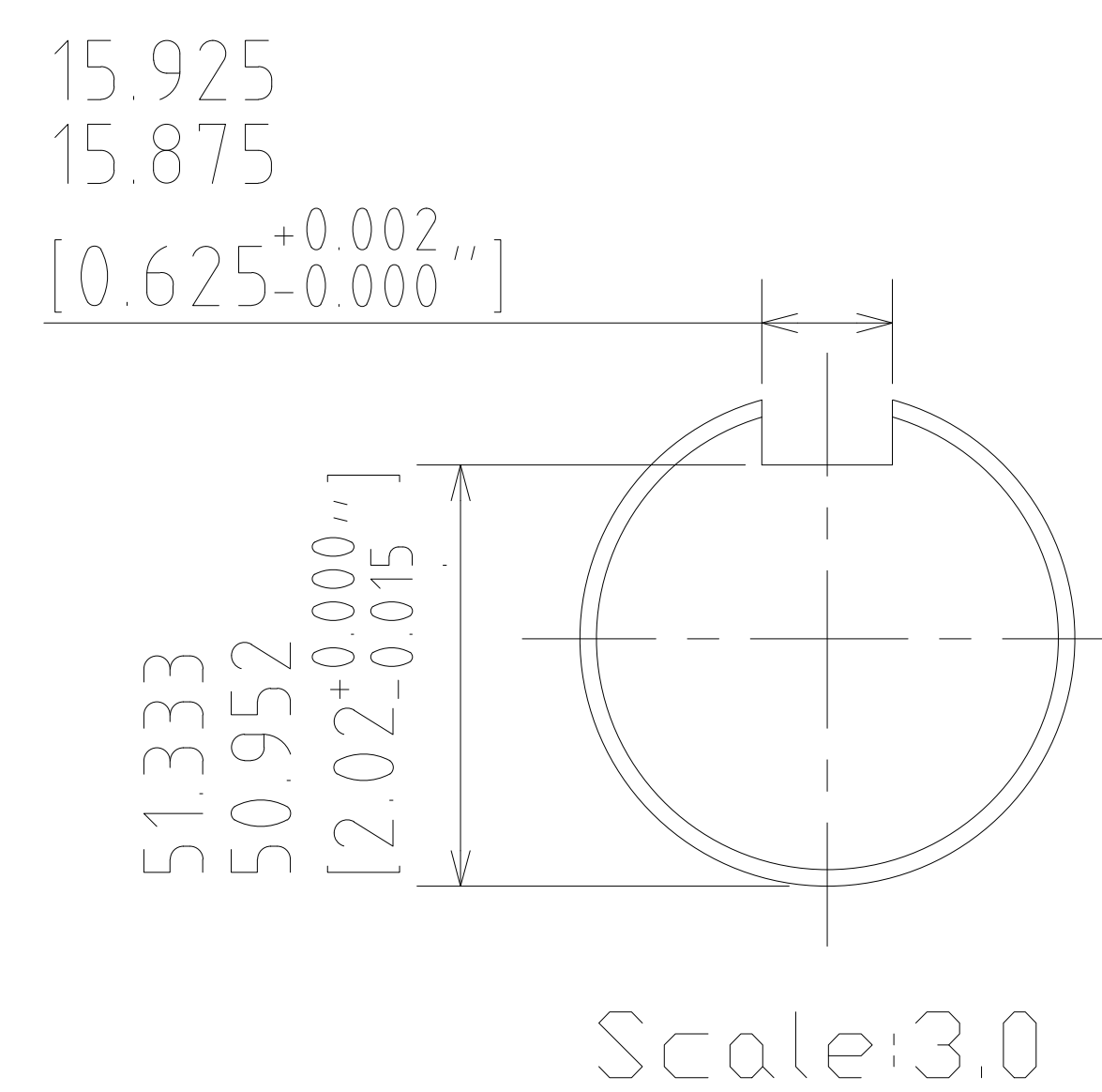

UNITS: INCHES

ROTATION FROM NDE

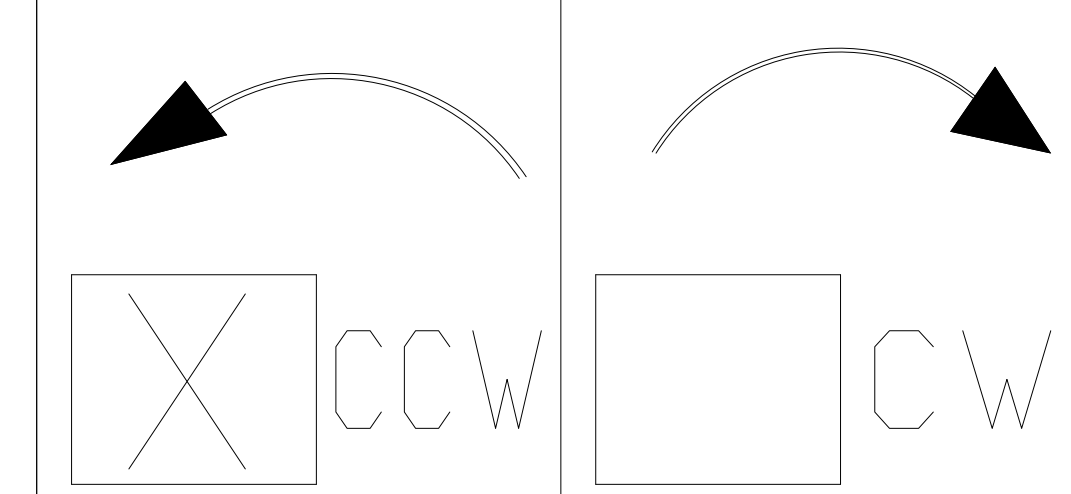

NOTES:

1. MAIN CONDUIT BOX MAY BE ROTATED IN 90° INCREMENTS
2. STANDARD PRODUCT USES BI-DIRECTIONAL FAN. OPPOSITE ROTATION AVAILABLE ONLY BY CONNECTION CHANGE.
3. KEY DIMENSIONS EQUAL 5/8"-5/8"-3" (MOTOR SUPPLIED WITH KEY)

TOSHIBA RESERVES THE RIGHT TO MAKE CHANGES OF TECHNICAL IMPROVEMENT AND THE DATA MAY CHANGE WITHOUT NOTICE  PRELIMINARY

DO NOT USE FOR CONSTRUCTION, INSTALLATION, OR APPLICATION PURPOSES UNLESS THE DRAWING IS MARKED AS CERTIFIED  CERTIFIED

**TOSHIBA** SEVERE DUTY **EQP Global SD**  
 www.toshiba.com/tic  
 TOSHIBA INTERNATIONAL CORPORATION

TOTALLY ENCLOSED FAN COOLED  
 HORIZONTAL FOOT MOUNT  
 3 PHASE INDUCTION MOTOR  
 S444/5TS F1 ASSEMBLY

DRAWING #: MDSL V700-11  
 REV. DATE: Nov-12-18 REV. #: \_\_\_\_\_ PER: MAI HUYEN  
 REV. DESCRIP: \_\_\_\_\_

**TYPICAL MOTOR PERFORMANCE DATA**

Model: 1504SDSA41B-P

HP	kW	Pole	FL RPM	Frame	Voltage	Hz	Phase	FL Amps
150	110	4	1785	S445T	230/460	60	3	338/169
Enclosure	IP	Ins. Class	S.F.	Duty	NEMA Nom. Eff.	NEMA Design	kVA Code	Ambient (°C)
TEFC	55	F	1.15	CONT	95.8	B		40 C

Load	HP	kW	Amperes	Efficiency (%)	Power Factor (%)
Full Load	150.00	111.9	168	96.1	86.5
¾ Load	112.50	83.9	128	95.6	85.6
½ Load	75.00	55.9	91	94.2	81.7
¼ Load	37.50	28.0	58	89.6	66.6
No Load			44.0		
Locked Rotor			1064		24.7

Torque				Rotor wk <sup>2</sup>
Full Load (lb-ft)	Locked Rotor (% FLT)	Pull Up (% FLT)	Break Down (% FLT)	Inertia (lb-ft <sup>2</sup> )
441	155	105	230	67.94

Safe Stall Time(s)		Sound Pressure dB(A) @ 1M	Bearings*		Approx. Motor Weight (lbs)
Cold	Hot		DE	NDE	
35	15	84	6318C3	6316C3	

\*Bearings are the only recommended spare part(s).

**Motor Options:**  
Product Family:EQP Global SD  
Mounting:Footed,Shaft:T Shaft

Customer	
Customer PO	
Sales Order	
Project #	

Tag:

All characteristics are average expected values.

**TOSHIBA INTERNATIONAL CORPORATION · HOUSTON, TEXAS U.S.A.**

Engineering	mccampbell	Doc. Written By	D. Suarez	Doc.# / Rev	MPCF-1119 / 0
Engr. Date	11/12/2018	Doc. Approved By	M. Campbell	Doc. Issued	6/8/2011

**SPEED TORQUE/CURRENT CURVE**

Model: 1504SDSA41B-P

HP	kW	Pole	FL RPM	Frame	Voltage	Hz	Phase	FL Amps
150	110	4	1785	S445T	230/460	60	3	338/169
Enclosure	IP	Ins. Class	S.F.	Duty	NEMA Nom. Eff.	NEMA Design	kVA Code	Ambient (°C)
TEFC	55	F	1.15	CONT	95.8	B		40 C
Locked Rotor Amps	Rotor wk <sup>2</sup> Inertia (lb-ft <sup>2</sup> )	Torque						Break Down (%)
		Full Load (lb-ft)	Locked Rotor (%)	Pull Up (%)				
1064	67.94	441	155	105			230	

**Design Values**

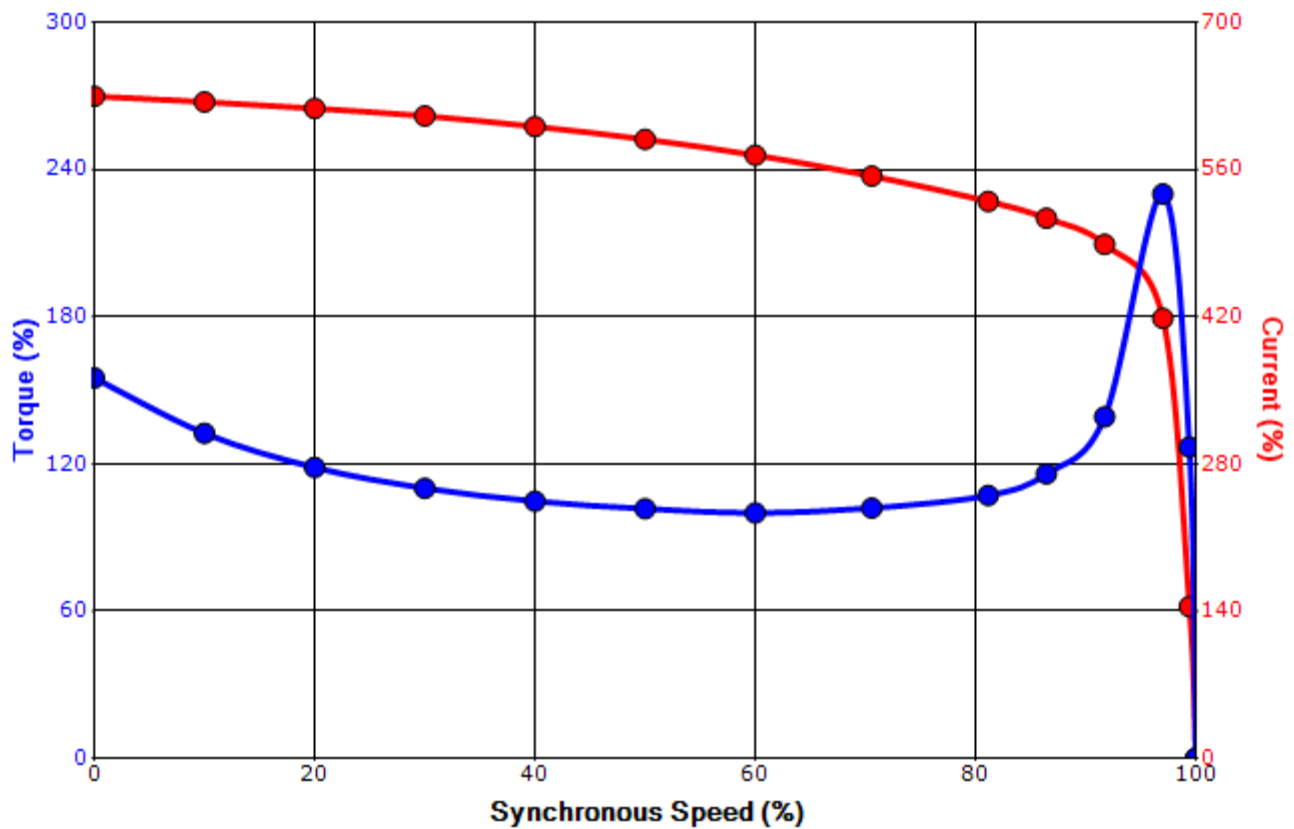

Customer		wk <sup>2</sup> Load Inertia (lb-ft <sup>2</sup> )	-
Customer PO		Load Type	-
Sales Order		Voltage (%)	100
Project #		Accel. Time	-

Tag:

All characteristics are average expected values.

**TOSHIBA INTERNATIONAL CORPORATION · HOUSTON, TEXAS U.S.A.**

Engineering	mcampbell	Doc. Written By	D. Suarez	Doc.# / Rev	MPCF-1121 / 0
Engr. Date	11/12/2018	Doc. Approved By	M. Campbell	Doc. Issued	6/8/2011

**Motor Connection Diagrams**  
12 Leads

Across-the-Line Starting / Running Connections

Low Voltage Delta



High Voltage Delta



Switch L1 and L2 to reverse rotation

Suitable for Wye-Delta Starting and Limited Part-Winding-Starting.  
Please Contact Toshiba International for specific connections.