

Data sheet for three-phase Squirrel-Cage-Motors SIMOTICS

Motor type: **GP100A** FS: **184T - 2p - 5 hp -**

Client order no.	Item-No.	Offer no.
Order no.	Consignment no.	Project
Remarks		

Electrical data

U [V]	Δ/Y	f [Hz]	P [HP]	P [kW]	n [rpm]	I Load [Amps]					LRC	Nom. Eff Load [%]			Pwr. Factor Load [%]			Torque [lb-ft]	T _A /T _N LRT [%]	T _k /T _N BDT [%]
						4/4	3/4	1/2	0	4/4		3/4	2/4	4/4	3/4	2/4				
575	Y	60	5.00	4.00	3,600	4.80	3.70	2.70	1.60	36.8	88.5	89.1	88.2	88.2	85.9	78.1	7.5	173	427	
Frame Type: 184T		Type of constr.: (G) Round body - C-Face				Ins. Cl.: Standard Class F Insulation		Motor Prot.: (A) Without Protection			NEMA Des.: B		S.F.: 1.15							
Mtr. WT: 79						Temp. Rise Cl.: B		Amb. Temp.: + 40 to -20 °C @1000 m			kVA: J		IP 55							

Mechanical data

Sound level (SPL / SWL) at 60 Hz	69.0 dB(A) / 81.0 dB(A)		Thickener	Polyurea					
Octave Band Center Frequencies Hertz			Safe Stall Time Hot	15 s					
250	500	1000	2000	4000	8000	Hz	Safe Stall Time Cold	29 s	
SPL@3	49.0	61.0	66.0	64.0	60.0	50.0	dB(A)	Frame material	aluminum
Moment of inertia	0.2 Lb-ft ²		Color, paint shade	Standard Paint - RAL7030					
Ext Load Inertia Capability:	57.0 Lb ft ²		Coating (paint finish)	Standard Alkyed + Epoxy (C2)					
Bearings			Ventilation Type						
Bearing DE NDE	6206 ZZ C3 S0		6206 ZZ C3 S0	Method of cooling	TEFC				
Bearing_Type	Ball Bearing		Ball Bearing	Direction of rotation	Bidirectional				
AFBMA:	30BC02JPP30		30BC02JPP30	Fan Material	Polypropylen				
Grease			VFD	CT: 4:1 VT: 20:1					
Capacity	0.2 oz		0.2 oz	Space heaters	without				
Grease Type:	Exxon Mobile EM		Brake:	without					

Terminal box

Lead Wire Connection		3 LEAD - WYE			Terminal box position	(3) F-1, Standard Floor Mount, T. Box LHS
Voltage	L1	L1	L1	Connected together	Material of terminal box	Aluminium
----	----	----	----	----	Cable entry	.75" NPT
----	T1	T2	T3	----		

Notes:

I_L/I_N = locked rotor current / current nominal
M_L/M_N = locked rotor torque / torque nominal
M_B/M_N = break down torque / nominal torque

3) Value is valid only for DOL operation with motor design IC411
2) at rated power / at full load

responsible dep. DI MC LVM	technical reference	created by DT Configurator	approved by	<i>Technical data are subject to change! There may be discrepancies between software and hardware versions</i>	
	document type datasheet	document status released		customer	
	title 1LE2121-1CA31-3GA3	document number			
© Siemens AG 2022	rev. 01	creation date 2022-04-08 16:56	language en	Page 1/1	

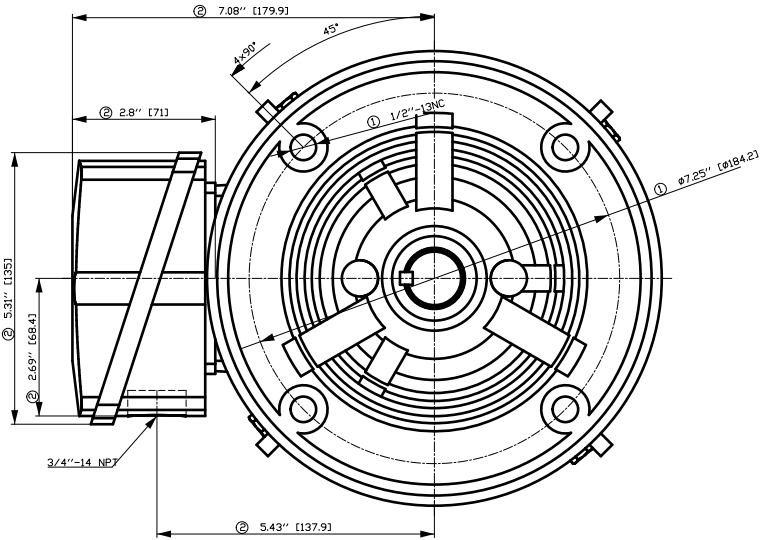

- ① Tolerances according to NEMA std.
- ② All these dimensions corresponding to assemblies and castings shall have a tolerance as per DIN standard 1686-GTB 19.
- ③ Not according to NEMA std.

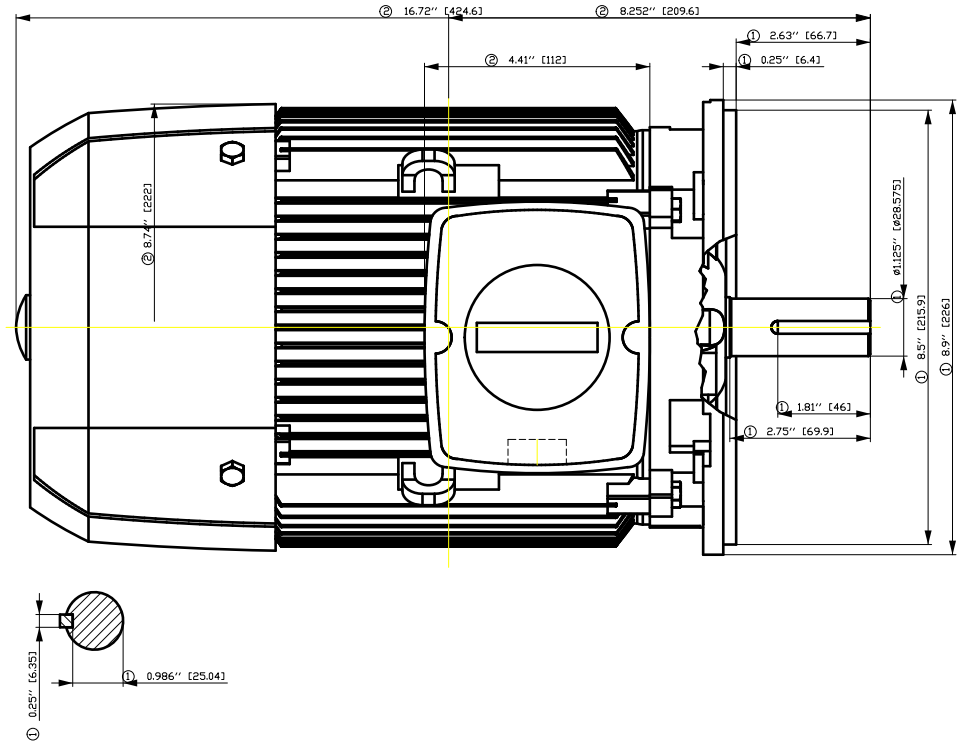

Tolerance	Surface	Material	Weight	Scale	
F50GFGF#00#F#00#	Author	ÖS T a : ^ & @ } *	E		
E	Creator				ÖVS
	Approval				
	Department				
	Change Order	MLFB		Doc Type	
	Doc State	I B B G	Item No	Paper Size	
	Revision	Index	Doc No	1st Language	
				2nd Language	
© Siemens AG 2018	Project No	E	Ref No	E	
				Sheet	
				F of F	

SIEMENS INDUSTRY, INC.

HP 5 VOLTS < 600V RPM 3600 TYPE GP100A
HZ 60 PHASE 3 FRAME 184T NEMA B

TORQUE & CURRENT VS. SPEED

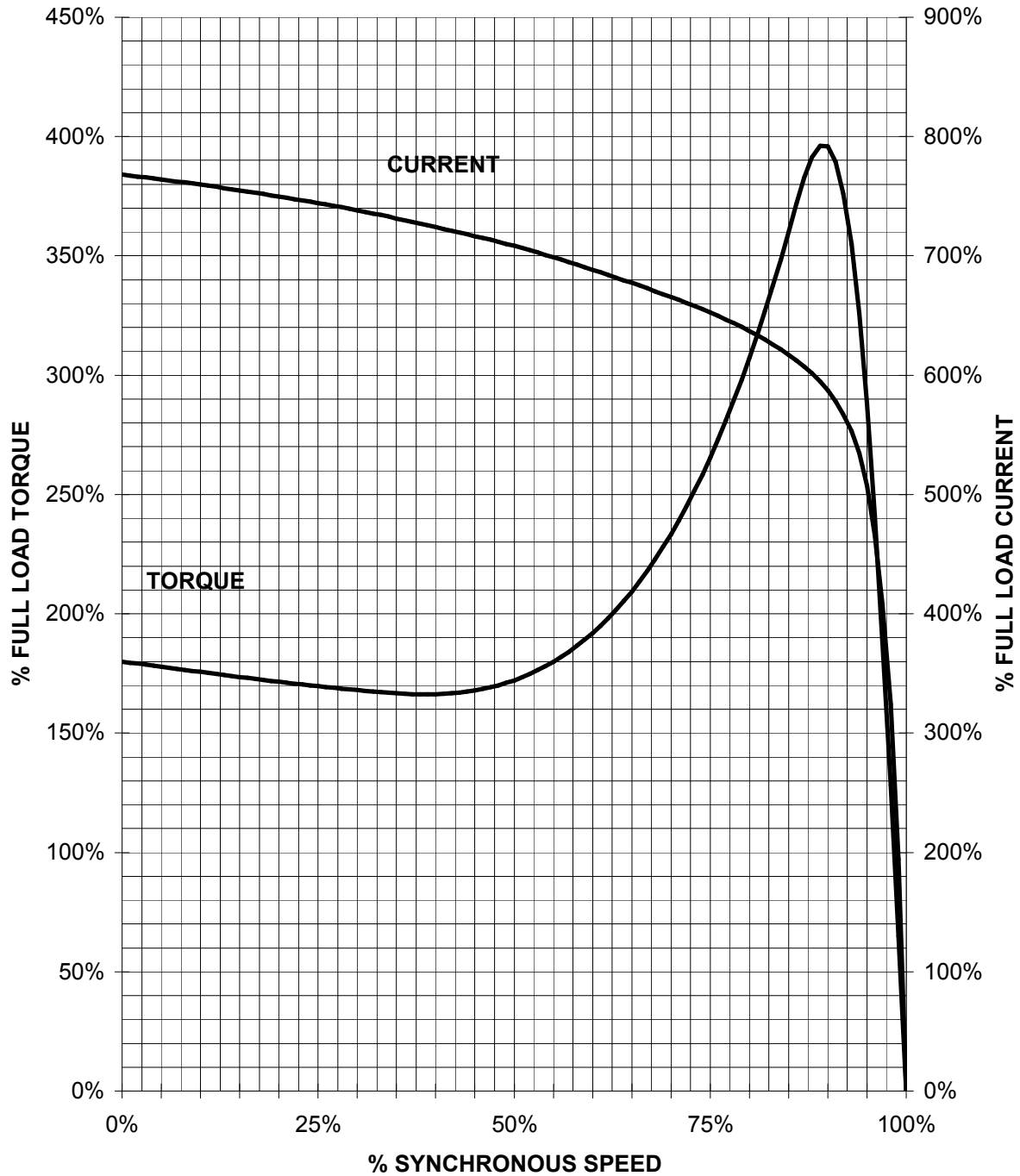

CUSTOMER: _____ ORDER#: _____

5 HP 3600 RPM 184 FRAME 575 VOLTS 3 PHASE NEMA DESIGN B

SIEMENS INDUSTRY, INC.
PERFORMANCE CURVE
GP100A NP

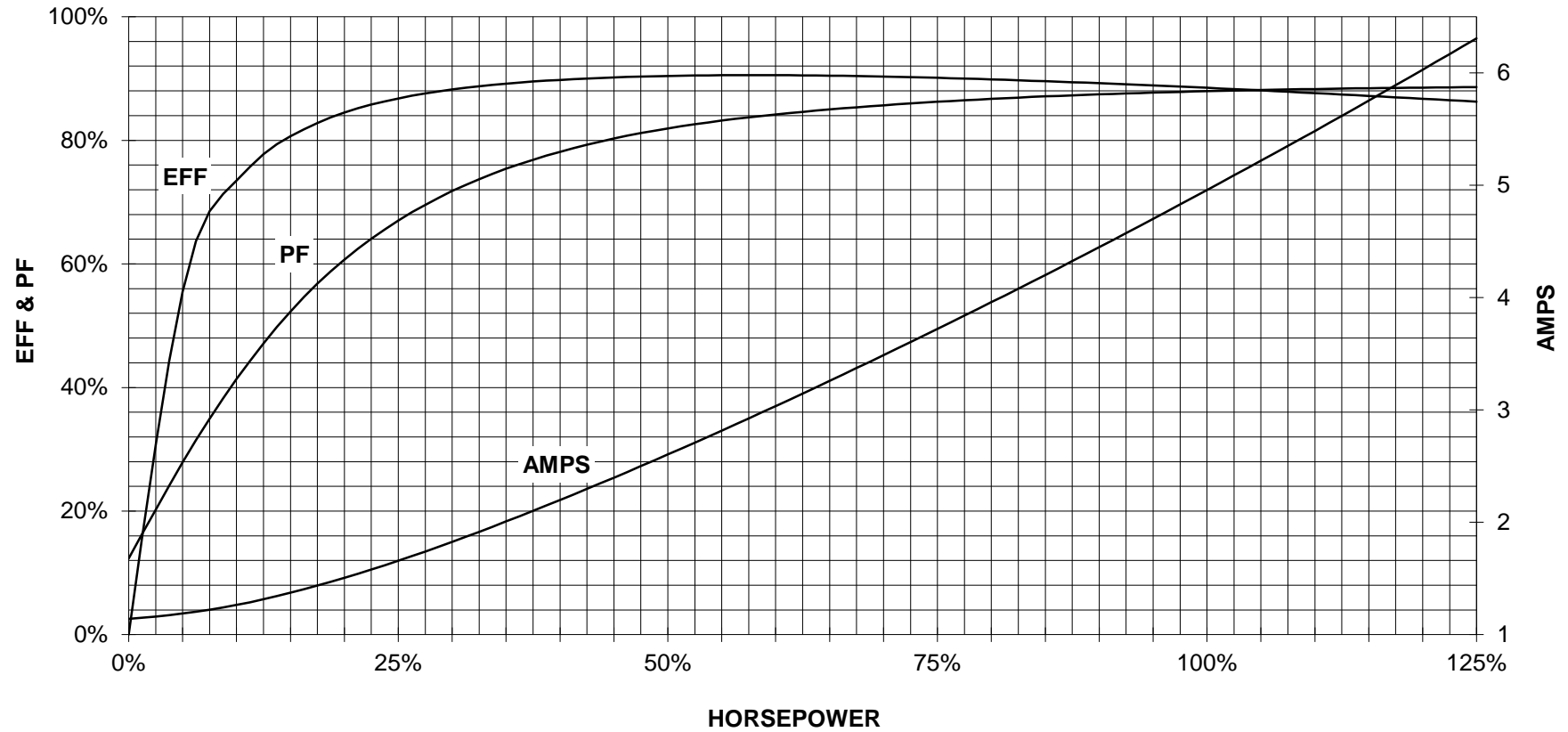

CUSTOMER _____ ORDER # _____ PO # _____

PERFORMANCE BASED ON DESIGN CALCULATIONS. SUBJECT TO CHANGE WITHOUT NOTICE.

REV. 1

Main terminal diagram



3 LEAD WYE			
LINES			CONN.
L1	L2	L3	
T1	T2	T3	Y

responsible dep.
DI MC LVM

technical reference

created by

approved by

Project

SIEMENS

document type
Wiring Diagram

title
1LE2121-1CA31-3GA3

document status
free

document number

customer