

Data sheet for three-phase Squirrel-Cage-Motors SIMOTICS

Motor type: **GP100A** FS: 213T - 2p - 7.5 hp -

Client order no.	Item-No.	Offer no.
Order no.	Consignment no.	Project

Remarks

Electrical data

U [V]	Δ/Y	f [Hz]	P [HP]	P [kW]	n [rpm]	I Load [Amps]					LRC	Nom. Eff Load [%]			Pwr. Factor Load [%]			Torque [lb-ft]	T _A /T _N LRT [%]	T _k /T _N BDT [%]
						4/4	3/4	1/2	0	4/4		3/4	2/4	4/4	3/4	2/4				
460	Y	60	7.50	5.50	3,600	8.80	6.70	5.00	3.00	63.0	89.5	90.1	89.6	89.2	86.8	78.5	11.0	182	500	
230	YY	60	7.50	5.50	3,600	17.60	13.47	9.98	6.00	126.0	89.5	90.1	89.6	89.2	86.8	78.5	11.0	182	500	
400	Y	50	5.00		2,948	6.80	5.48	4.33	3.10	64.0	87.9	88.1	87.4	88.1	83.1	72.6	8.9	269	406	
200	YY	50	5.00		2,948	13.60	10.96	8.66	6.20	128.0	87.9	88.1	87.4	88.1	83.1	72.6	8.9	269	406	

without

Frame Type: 213T	Type of constr.: (A) Foot mounted - End shield	Ins. Cl.: Standard Class F Insulation	Motor Prot.: (A) Without Protection	NEMA Des.: B	S.F.: 1.15
Mtr. WT: 160		Temp. Rise Cl.: B	Amb. Temp.: + 40 to -20 °C @1000 m	kVA: H	IP 55

Mechanical data

Sound level (SPL / SWL) at 60 Hz	66.0 dB(A) / 78.0 dB(A)							Thickener	Polyurea
Octave Band Center Frequencies Hertz								Safe Stall Time Hot	17 s
	250	500	1000	2000	4000	8000	Hz	Safe Stall Time Cold	30 s
SPL@3	53.0	55.0	63.0	62.0	58.0	47.0	dB(A)	Frame material	aluminum
Moment of inertia	0.4 Lb-ft ²							Color, paint shade	Standard Paint - RAL7030
Ext Load Inertia Capability:	83.0 Lb ft ²							Coating (paint finish)	Standard Alkyed + Epoxy (C2)
Bearings								Ventilation Type	
Bearing DE NDE	6208 ZZ C3 S0			6208 ZZ C3 S0				Method of cooling	TEFC
Bearing_Type	Ball Bearing			Ball Bearing				Direction of rotation	Bidirectional
AFBMA:	40BC02JPP30			40BC02JPP30				Fan Material	Polypropylen
Grease								VFD	CT: 4:1 VT: 20:1
Capacity	0.3 oz			0.3 oz				Space heaters	without
Grease Type:	Exxon Mobile EM							Brake:	without

Terminal box

Lead Wire Connection	9 LEAD - WYE				Terminal box position	(3) F-1, Standard Floor Mount, T. Box LHS
Voltage	L1	L1	L1	Connected together	Material of terminal box	Aluminium
LOW	T1 T7	T2 T8	T3 T9	T4 T5 T6	Cable entry	1" NPT
HIGH	T1	T2	T3	T4 T7-T5 T8-T6 T9		

Notes:

I_L/I_N = locked rotor current / current nominal
M_L/M_N = locked rotor torque / torque nominal
M_d/M_N = break down torque / nominal torque

3) Value is valid only for DOL operation with motor design IC411
2) at rated power / at full load

responsible dep. DI MC LVM	technical reference	created by DT Configurator	approved by	<i>Technical data are subject to change! There may be discrepancies between software and hardware versions</i>	
	document type datasheet	document status released	customer		
	title 1LE2121-2AA11-4AA3	document number	rev. 01	creation date 2022-04-08 17:57	language en
© Siemens AG 2022				Page 1/1	

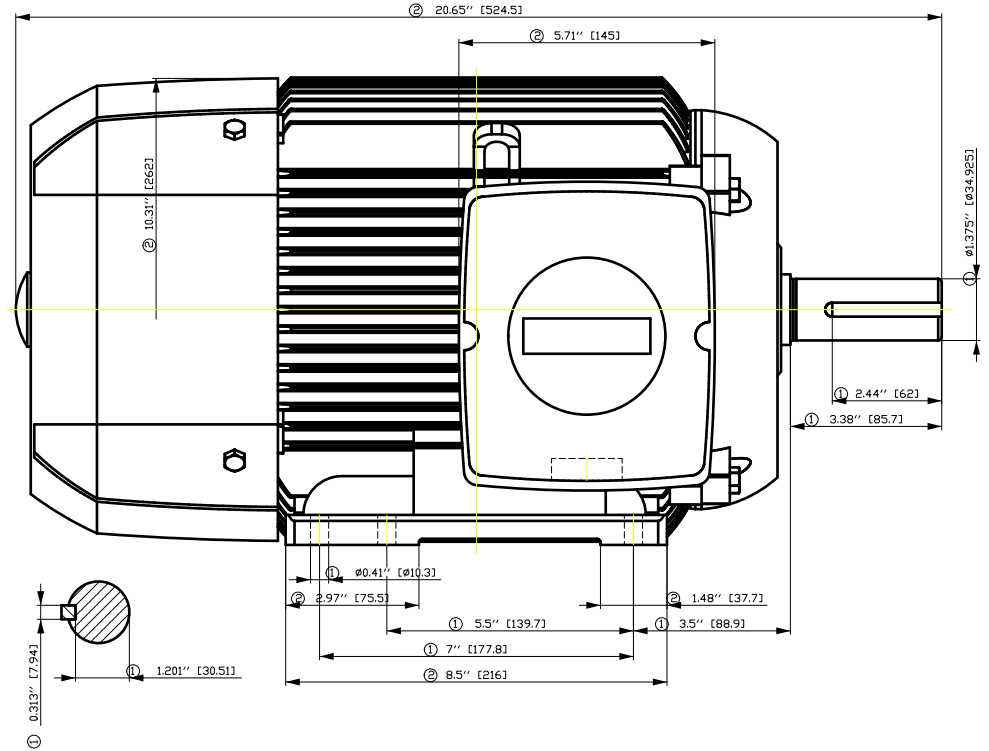
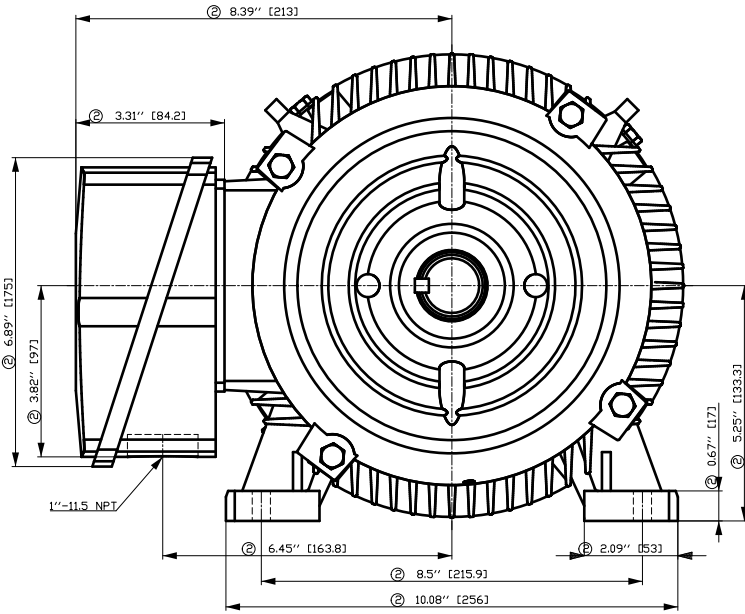

- ① Tolerances according to NEMA std.
- ② All these dimensions corresponding to assemblies and castings shall have a tolerance as per DIN standard 1686-GTB 19.
- ③ Not according to NEMA std.

Tolerance	Surface	Material	Weight	Scale
F50GF60DFE CCH	Author	ÖS	E	
E	Creator			
	Approval			
	Department			
	Change Order	MFB		Doc Type
SIEMENS	Doc State	I BGG	Item No	Paper Size CCH
	Revision	Index RS	Doc No	1st Language ^
				2nd Language â
© Siemens AG 2018	Project No E	Ref No E		Sheet F of F

SIEMENS INDUSTRY, INC.

HP 7,5 VOLTS < 600V RPM 3600 TYPE GP100A
HZ 60 PHASE 3 FRAME 213T NEMA B

TORQUE & CURRENT VS. SPEED

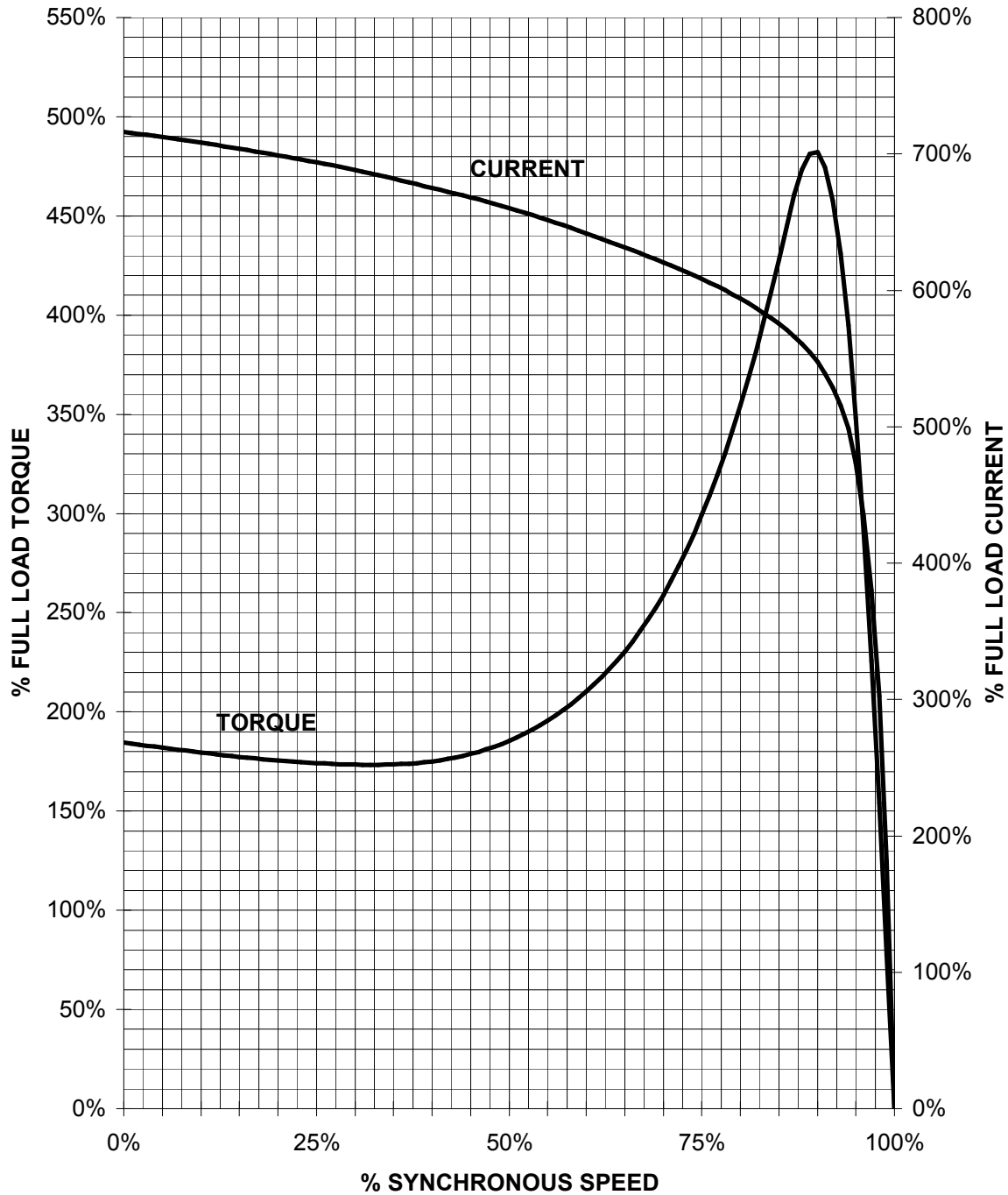

CUSTOMER: _____ ORDER#: _____

7.5 HP 3600 RPM 213 FRAME 460 VOLTS 3 PHASE NEMA DESIGN B

SIEMENS INDUSTRY, INC.
PERFORMANCE CURVE
GP100A NP

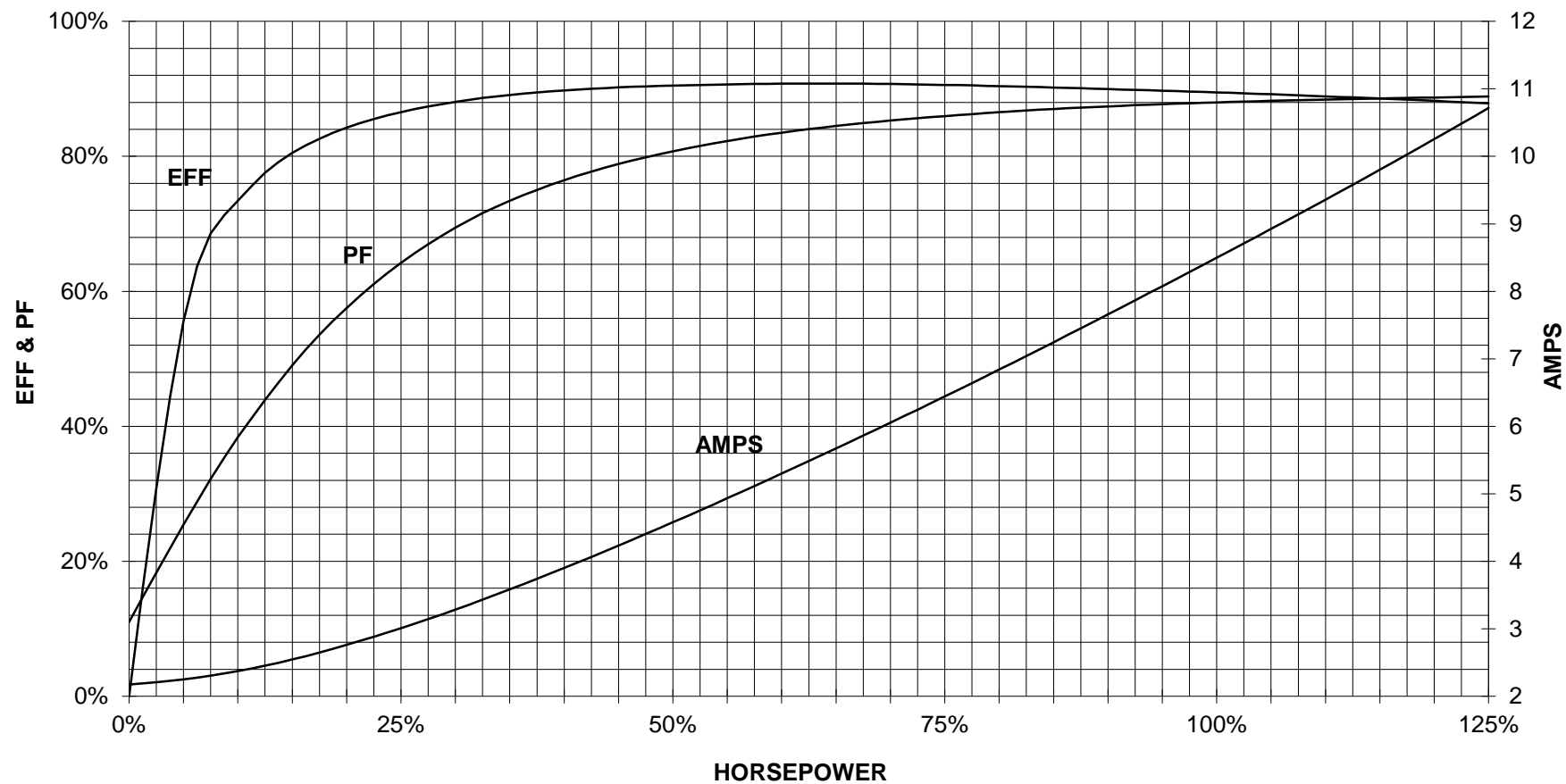

CUSTOMER _____ ORDER # _____ PO # _____

PERFORMANCE BASED ON DESIGN CALCULATIONS. SUBJECT TO CHANGE WITHOUT NOTICE.

REV. 1

Main terminal diagram



9 LEAD WYE						
Volts	LINES			CONNECTED TOGETHER	CONN.	
	L1	L2	L3			
LOW	T1 T7	T2 T6	T3 T9	T4 T5 T6	YY	
HIGH	T1	T2	T3	T4 T7-T5 T8-T6 T9	Y	

responsible dep. DI MC LVM	technical reference	created by	approved by	Project
SIEMENS	document type Wiring Diagram	document status free		customer
	title 1LE2121-2AA11-4AA3	document number		
© Siemens AG 2019	rev. 01	creation date 12/03/2019	language en	Page 1/1