

# Data sheet for three-phase Squirrel-Cage-Motors SIMOTICS

Motor type: **GP100A** FS: 213T - 4p - 7.5 hp -

Client order no.	Item-No.	Offer no.
Order no.	Consignment no.	Project
Remarks		

## Electrical data

U [V]	$\Delta/Y$	f [Hz]	P [HP]	P [kW]	n [rpm]	I Load [Amps]					LRC	Nom. Eff Load [%]			Pwr. Factor Load [%]			Torque [lb-ft]	T <sub>A</sub> /T <sub>N</sub> LRT [%]	T <sub>k</sub> /T <sub>N</sub> BDT [%]
						4/4	3/4	1/2	0	4/4		3/4	2/4	4/4	3/4	2/4				
575	Y	60	7.50	5.50	1,800	7.80	6.40	5.10	4.00	50.4	91.7	91.7	90.7	78.9	72.3	60.5	22.0	273	455	

**without**

Frame Type: 213T	Type of constr.: (A) Foot mounted - End shield	Ins. Cl.: Standard Class F Insulation	Motor Prot.: (A) Without Protection	NEMA Des.: B	S.F.: 1.15
Mtr. WT: 144		Temp. Rise Cl.: B	Amb. Temp.: + 40 to -20 °C @1000 m	kVA: H	IP 55

## Mechanical data

Sound level (SPL / SWL) at 60 Hz	57.0 dB(A) / 69.0 dB(A)							Thickener	Polyurea
Octave Band Center Frequencies Hertz								Safe Stall Time Hot	25 s
	250	500	1000	2000	4000	8000	Hz	Safe Stall Time Cold	42 s
SPL@3	37.0	44.0	54.0	53.0	44.0	35.0	dB(A)	Frame material	aluminum
Moment of inertia	0.8 Lb-ft <sup>2</sup>							Color, paint shade	Standard Paint - RAL7030
Ext Load Inertia Capability:	39.0 Lb ft <sup>2</sup>							Coating (paint finish)	Standard Alkyed + Epoxy (C2)
<b>Bearings</b>								<b>Ventilation Type</b>	
Bearing DE   NDE	6208 ZZ C3 S0			6208 ZZ C3 S0			Method of cooling	TEFC	
Bearing_Type	Ball Bearing			Ball Bearing			Direction of rotation	Bidirectional	
AFBMA:	40BC02JPP30			40BC02JPP30			Fan Material	Polypropylen	
<b>Grease</b>								VFD	CT: 4:1 VT: 20:1
Capacity	0.3 oz			0.3 oz			Space heaters	without	
Grease Type:	Exxon Mobile EM							Brake:	without

## Terminal box

Lead Wire Connection				3 LEAD - WYE		Terminal box position	(3) F-1, Standard Floor Mount, T. Box LHS		
Voltage	L1	L1	L1	Connected together		Material of terminal box	Aluminium		
----	----	----	----	----		Cable entry	1" NPT		
----	T1	T2	T3	----					

### Notes:

I<sub>r</sub>/I<sub>N</sub> = locked rotor current / current nominal  
M<sub>r</sub>/M<sub>N</sub> = locked rotor torque / torque nominal  
M<sub>b</sub>/M<sub>N</sub> = break down torque / nominal torque

3) Value is valid only for DOL operation with motor design IC411  
2) at rated power / at full load

responsible dep. DI MC LVM	technical reference	created by DT Configurator	approved by	<i>Technical data are subject to change! There may be discrepancies between software and hardware versions</i>			
	document type datasheet	document status released		customer			
	title 1LE2121-2AB11-3AA3	document number					
© Siemens AG 2022	rev. 01	creation date 2022-04-08 18:02	language en	Page 1/1			

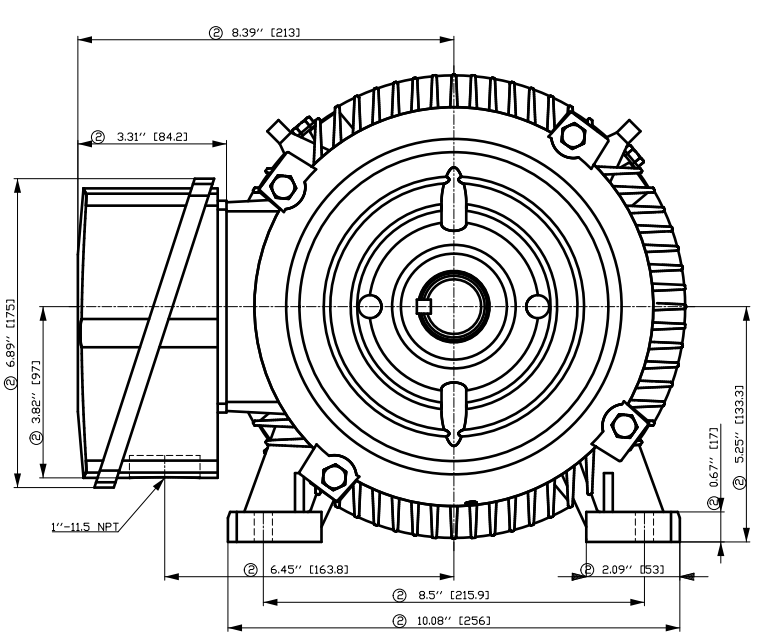

- ① Tolerances according to NEMA std.
- ② All these dimensions corresponding to assemblies and castings shall have a tolerance as per DIN standard 1686-GTB 19.
- ③ Not according to NEMA std.

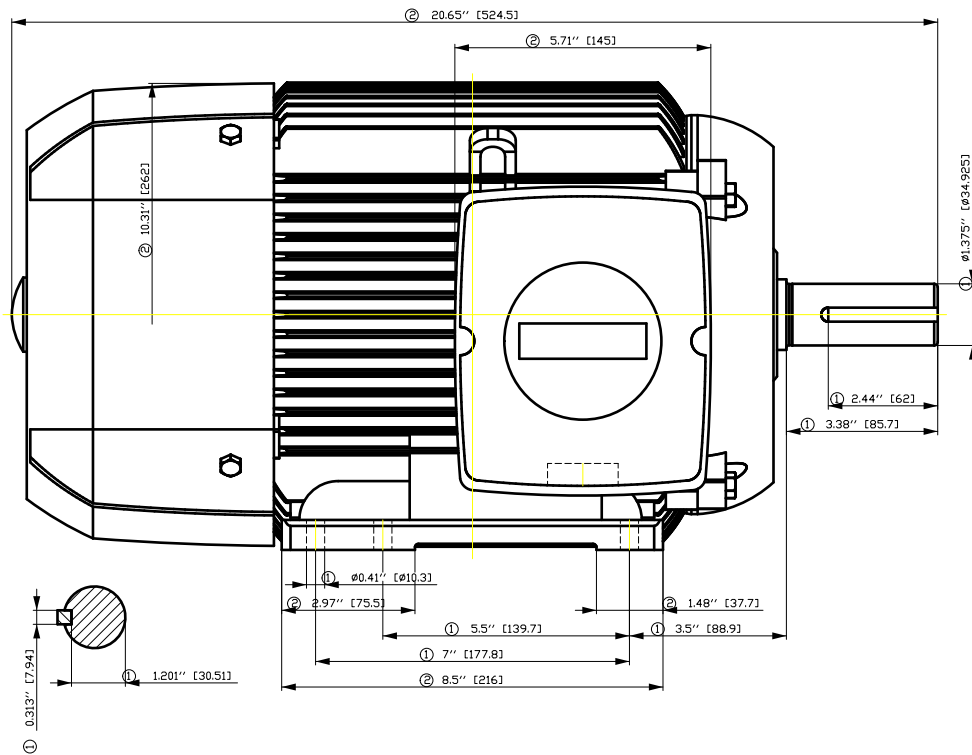

Tolerance	Surface	Material	Weight	Scale
F50GFGFCOFFHCEH E	Author Creator Approval Department Change Order	ÖVS Tæ : ^æ@ } *	E	{ {
	Doc State Revision	MLFB Item No Doc No		
SIEMENS	Index RS			
© Siemens AG 2018	Project No E	Ref No E		
			Doc Type 	Paper Size CH
				1st Language ^ } 2nd Language â ^
				Sheet F of F

# SIEMENS INDUSTRY, INC.

HP 7.5 VOLTS < 600V RPM 1800 TYPE GP100A  
HZ 60 PHASE 3 FRAME 213T NEMA B

## TORQUE & CURRENT VS. SPEED

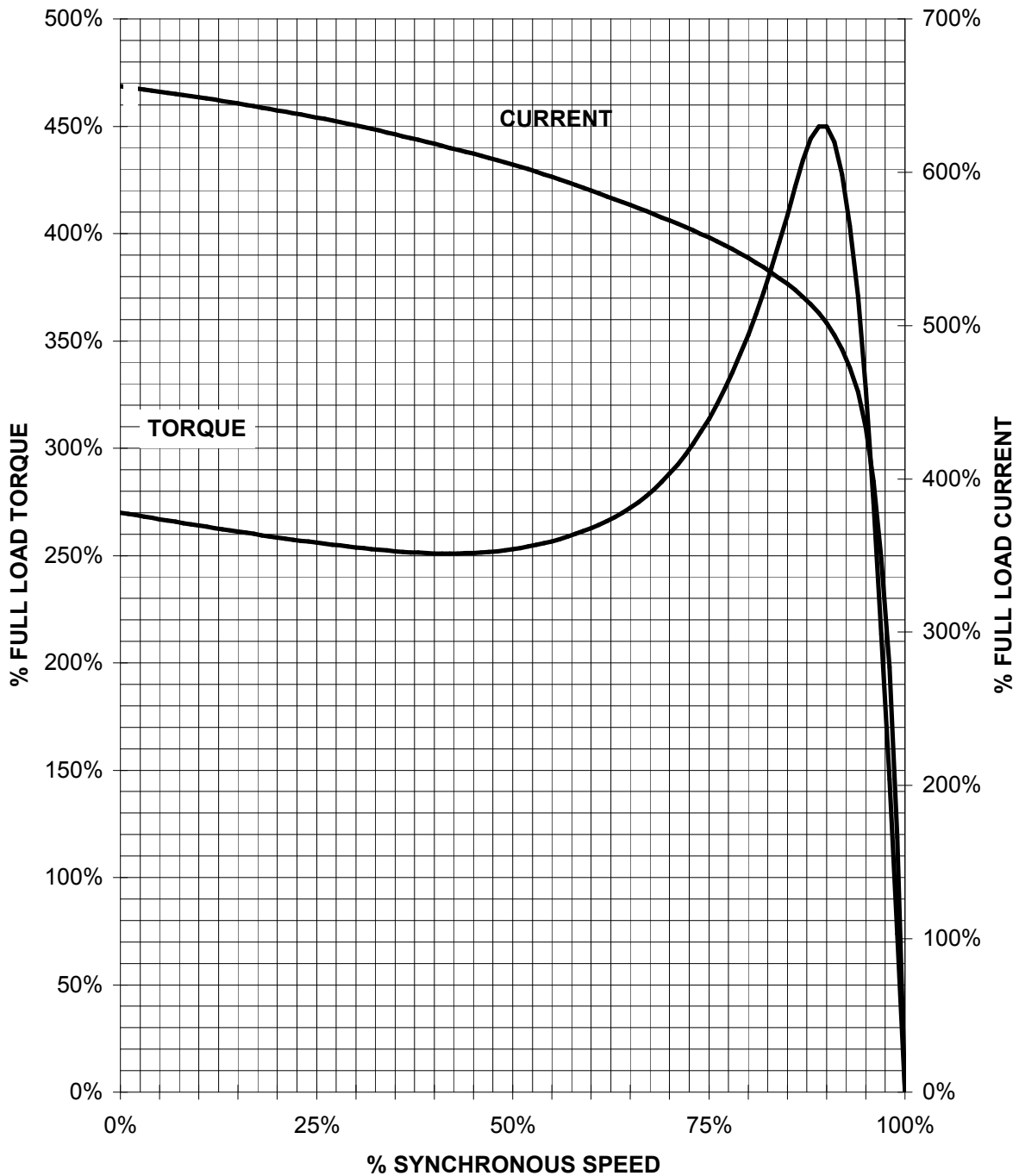

CUSTOMER: \_\_\_\_\_ ORDER#: \_\_\_\_\_

7.5 HP 1800 RPM 213 FRAME 575 VOLTS 3 PHASE NEMA DESIGN B

**SIEMENS INDUSTRY, INC.**  
**PERFORMANCE CURVE**  
**GP100A NP**

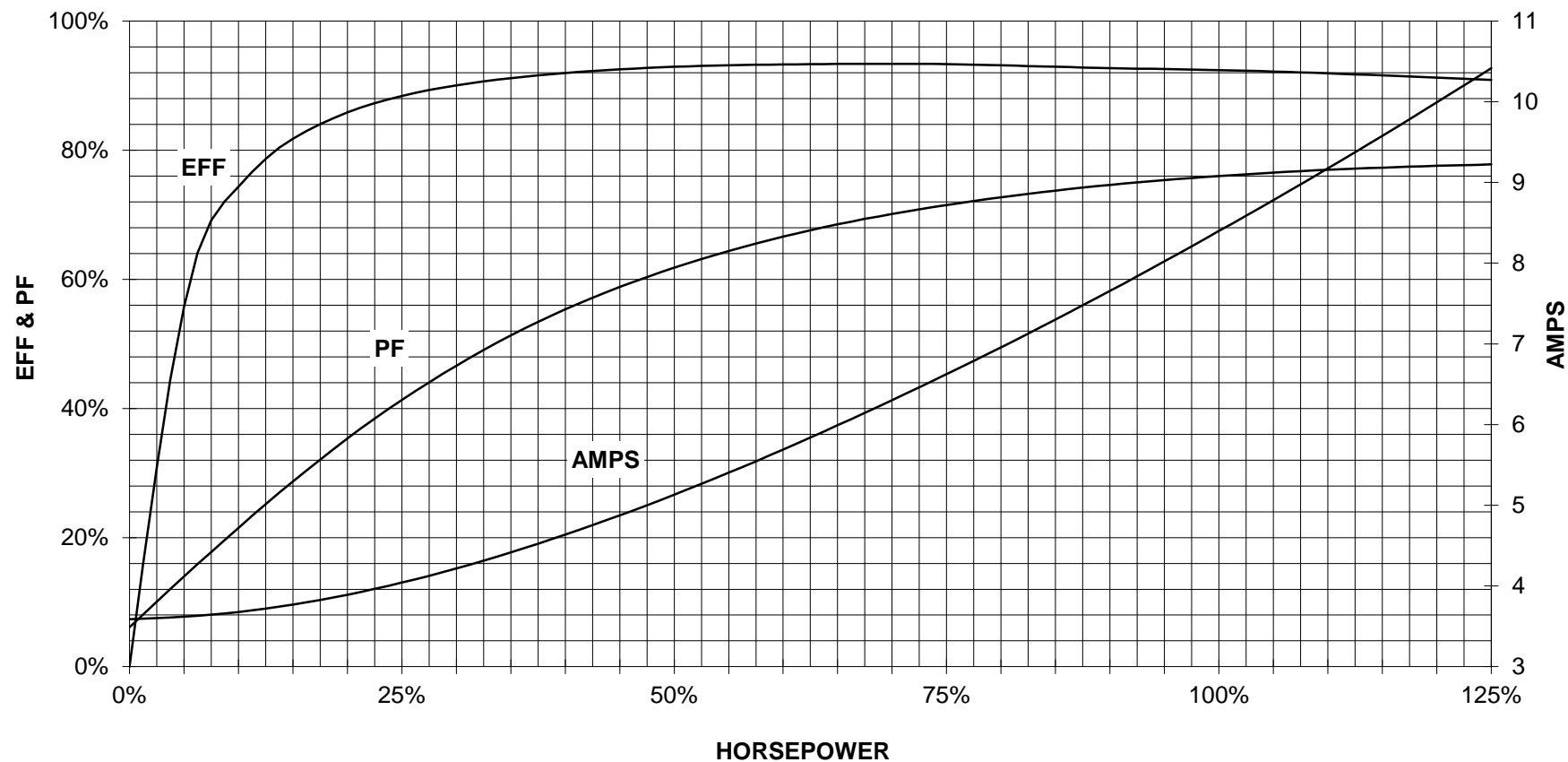

CUSTOMER \_\_\_\_\_ ORDER # \_\_\_\_\_ PO # \_\_\_\_\_

PERFORMANCE BASED ON DESIGN CALCULATIONS. SUBJECT TO CHANGE WITHOUT NOTICE.

REV. 1

Main terminal diagram



3 LEAD WYE			
LINES			CONN.
L1	L2	L3	
T1	T2	T3	Y

responsible dep.  
DI MC LVM

technical reference

created by

approved by

Project

**SIEMENS**

document type  
Wiring Diagram

title  
1LE2121-2AB11-3AA3

document status  
free

document number

customer