

Data sheet for three-phase Squirrel-Cage-Motors SIMOTICS

Motor type: **GP100A** FS: 213T - 4p - 7.5 hp -

Client order no.	Item-No.	Offer no.
Order no.	Consignment no.	Project
Remarks		

Electrical data

U [V]	Δ/Y	f [Hz]	P [HP]	P [kW]	n [rpm]	I Load [Amps]					LRC	Nom. Eff Load [%]			Pwr. Factor Load [%]			Torque [lb-ft]	T _A /T _N LRT [%]	T _k /T _N BDT [%]
						4/4	3/4	1/2	0	4/4		3/4	2/4	4/4	3/4	2/4				
575	Y	60	7.50	5.50	1,800	7.80	6.40	5.10	4.00	50.4	91.7	91.7	90.7	78.9	72.3	60.5	22.0	273	455	

without

Frame Type: 213T	Type of constr.: (E) Foot mounted - C-Face	Ins. Cl.:Standard Class F Insulation	Motor Prot.:(A) Without Protection	NEMA Des.: B	S.F.: 1.15
Mtr. WT:144		Temp. Rise Cl.: B	Amb. Temp.: + 40 to -20 °C @1000 m	kVA: H	IP 55

Mechanical data

Sound level (SPL / SWL) at 60 Hz	57.0 dB(A) / 69.0 dB(A)		Thickener	Polyurea					
Octave Band Center Frequencies Hertz			Safe Stall Time Hot	25 s					
	250	500	1000	2000	4000	8000	Hz	Safe Stall Time Cold	42 s
SPL@3	37.0	44.0	54.0	53.0	44.0	35.0	dB(A)	Frame material	aluminum
Moment of inertia	0.8 Lb-ft ²		Color, paint shade	Standard Paint - RAL7030					
Ext Load Inertia Capability:	39.0 Lb ft ²		Coating (paint finish)	Standard Alkyed + Epoxy (C2)					
Bearings			Ventilation Type						
Bearing DE NDE	6208 ZZ C3 S0		6208 ZZ C3 S0	Method of cooling	TEFC				
Bearing_Type	Ball Bearing		Ball Bearing	Direction of rotation	Bidirectional				
AFBMA:	40BC02JPP30		40BC02JPP30	Fan Material	Polypropylen				
Grease			VFD	CT: 4:1 VT: 20:1					
Capacity	0.3 oz		0.3 oz	Space heaters	without				
Grease Type:	Exxon Mobile EM		Brake:	without					

Terminal box

Lead Wire Connection	3 LEAD - WYE				Terminal box position	(3) F-1, Standard Floor Mount, T. Box LHS
Voltage	L1	L1	L1	Connected together	Material of terminal box	Aluminium
----	----	----	----	----	Cable entry	1" NPT
----	T1	T2	T3	----		

Notes:

I_r/I_N = locked rotor current / current nominal
M_r/M_N = locked rotor torque / torque nominal
M_b/M_N = break down torque / nominal torque

3) Value is valid only for DOL operation with motor design IC411
2) at rated power / at full load

responsible dep. DI MC LVM	technical reference	created by DT Configurator	approved by	<i>Technical data are subject to change! There may be discrepancies between software and hardware versions</i>	
	document type datasheet	document status released	customer		
	title 1LE2121-2AB11-3EA3	document number			
© Siemens AG 2022	rev. 01	creation date 2022-04-08 18:02	language en	Page 1/1	

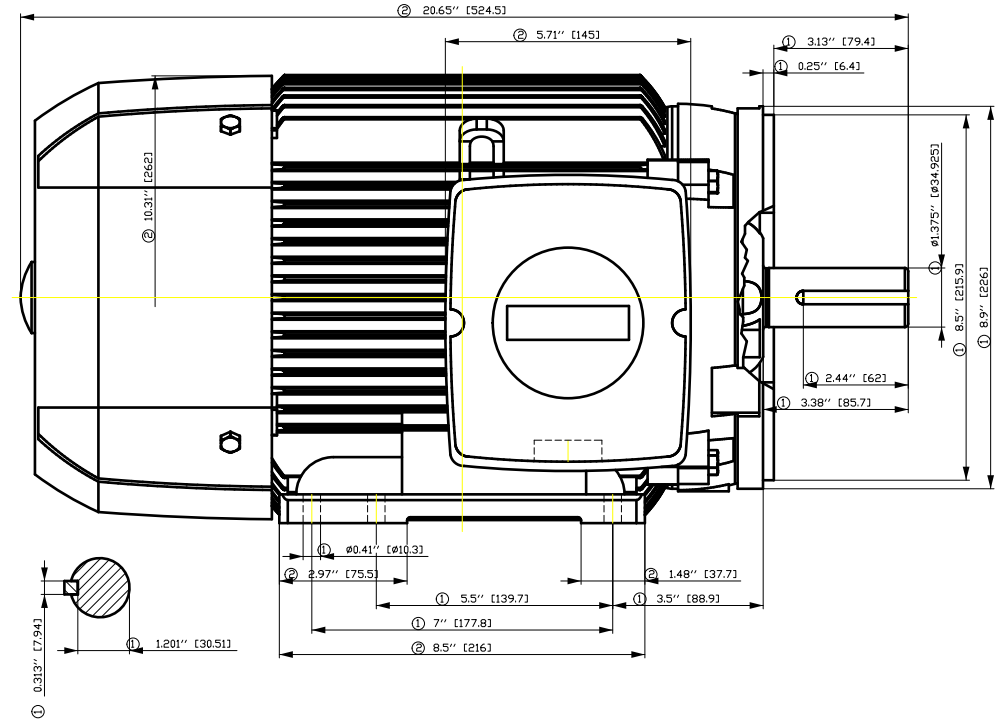
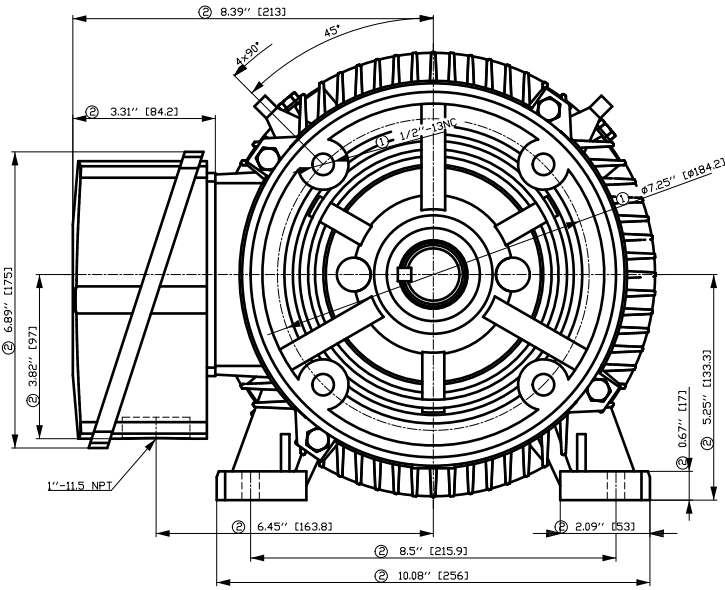

- ① Tolerances according to NEMA std.
- ② All these dimensions corresponding to assemblies and castings shall have a tolerance as per DIN standard 1686-GTB 19.
- ③ Not according to NEMA std.

Tolerance	Surface	Material	Weight	Scale
F50GF6COFFH0EH	Author	ÖS Tæ: ^æ@` }*	E	
E	Creator			
	Approval			
	Department	MLFB	Doc Type	/
	Change Order		Paper Size	CH
	Doc State	I BGG	Item No	1st Language ^
	Revision	Index RS	Doc No	2nd Language â^
© Siemens AG 2018	Project No	E	Ref No	E
			Sheet	F of F

SIEMENS INDUSTRY, INC.

HP 7.5 VOLTS < 600V RPM 1800 TYPE GP100A
HZ 60 PHASE 3 FRAME 213T NEMA B

TORQUE & CURRENT VS. SPEED

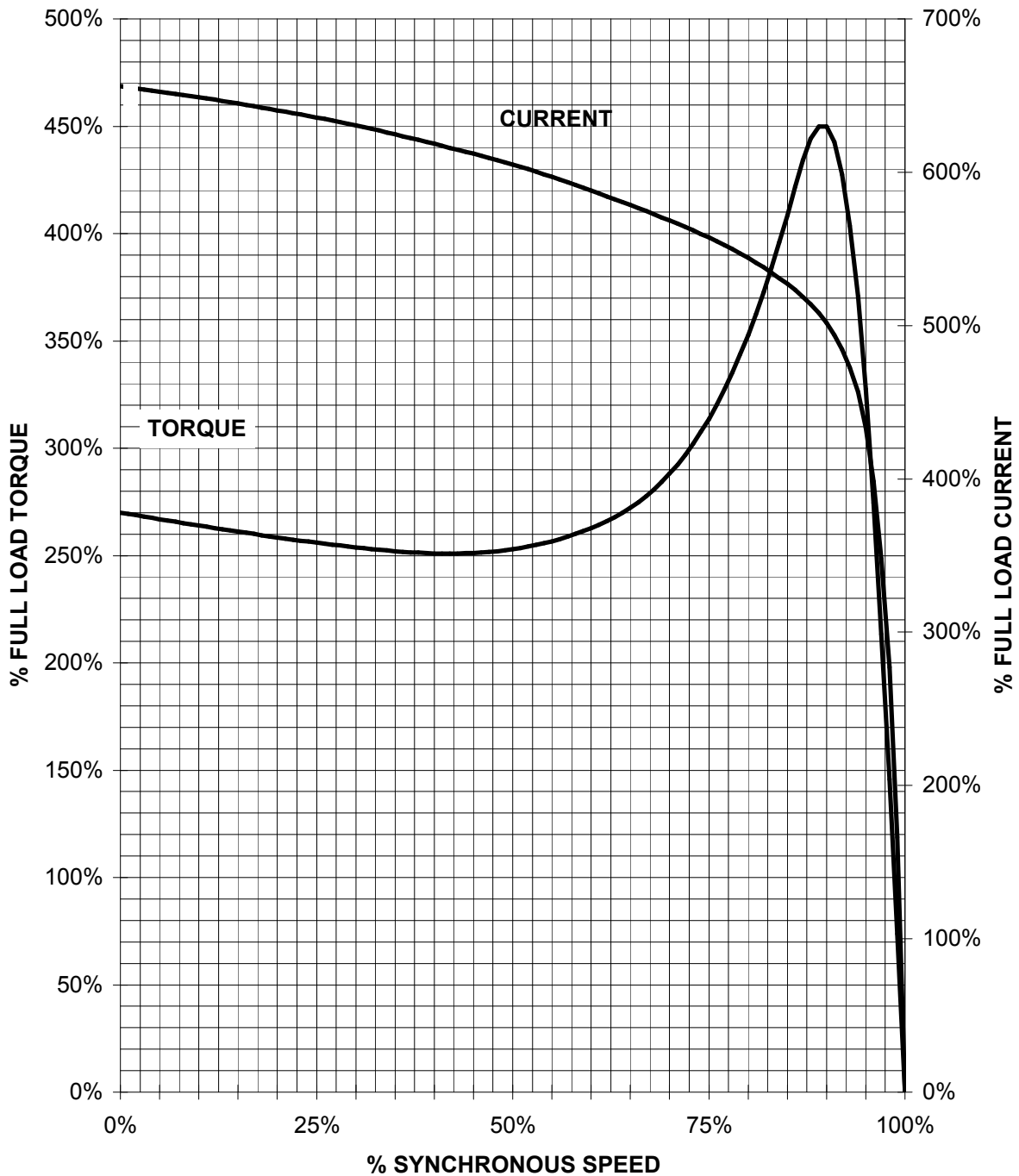

CUSTOMER: _____ ORDER#: _____

7.5 HP 1800 RPM 213 FRAME 575 VOLTS 3 PHASE NEMA DESIGN B

SIEMENS INDUSTRY, INC.
PERFORMANCE CURVE
GP100A NP

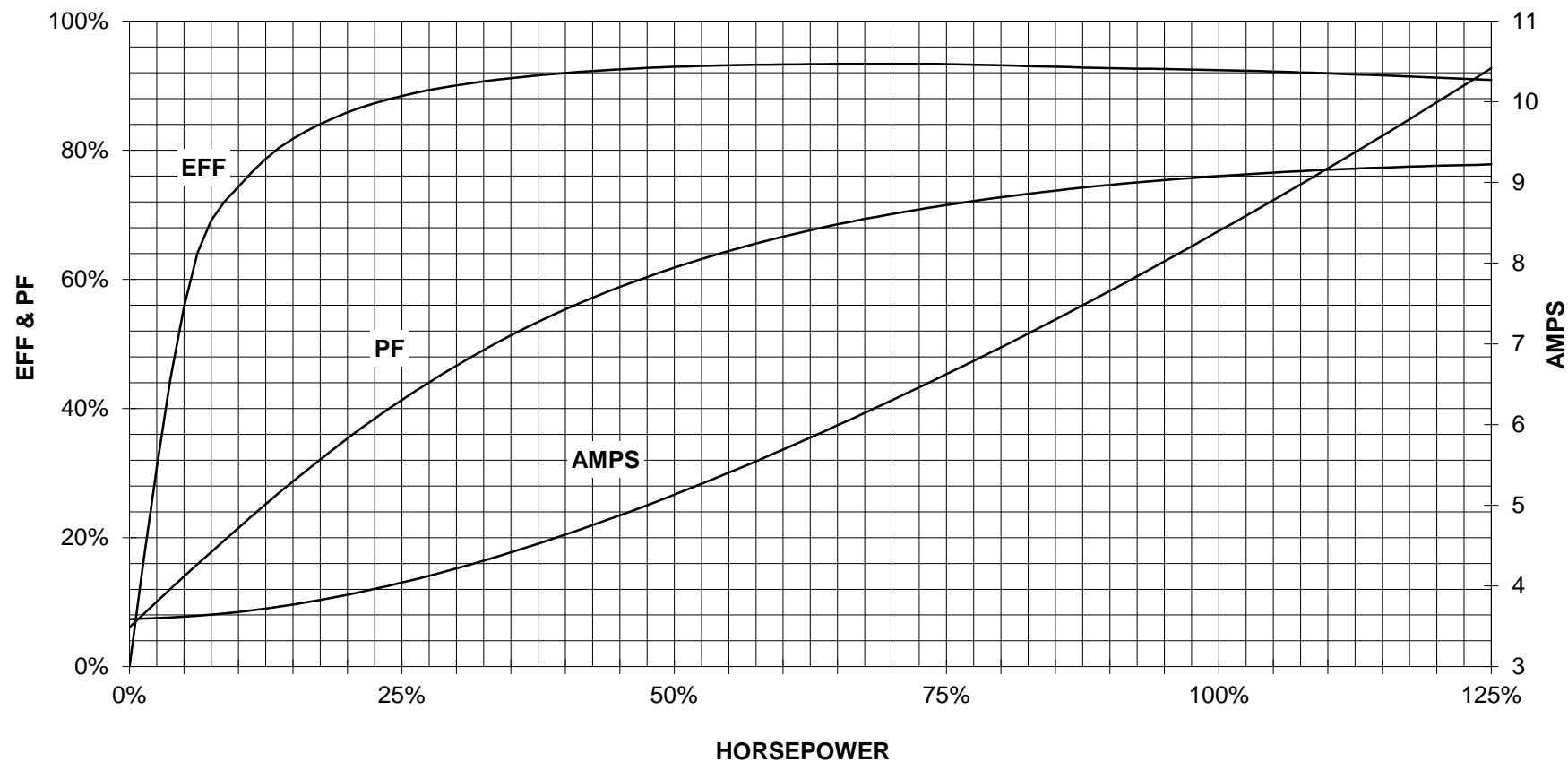

CUSTOMER _____ ORDER # _____ PO # _____

PERFORMANCE BASED ON DESIGN CALCULATIONS. SUBJECT TO CHANGE WITHOUT NOTICE.

REV. 1

Main terminal diagram



3 LEAD WYE			
LINES			CONN.
L1	L2	L3	
T1	T2	T3	Y

responsible dep. DI MC LVM	technical reference	created by	approved by	Project		
	document type Wiring Diagram		document status free		customer	
	title 1LE2121-2AB11-3EA3		document number			
© Siemens AG 2019			rev. 01	creation date 12/03/2019	language en	Page 1/1