

Data sheet for three-phase Squirrel-Cage-Motors SIMOTICS

Motor type: **GP100A** FS: 254T - 4p - 15 hp -

Client order no.	Item-No.	Offer no.
Order no.	Consignment no.	Project
Remarks		

Electrical data

U [V]	Δ/Y	f [Hz]	P [HP]	P [kW]	n [rpm]	I Load [Amps]					LRC	Nom. Eff Load [%]			Pwr. Factor Load [%]			Torque [lb-ft]	T _A /T _N LRT [%]	T _k /T _N BDT [%]
						4/4	3/4	1/2	0	4/4		3/4	2/4	4/4	3/4	2/4				
460	Y	60	15.00	11.00	1,800	19.00	15.20	11.80	8.50	116.0	92.4	92.8	92.3	80.0	74.7	64.5	44.0	184	234	
230	YY	60	15.00	11.00	1,800	38.00	30.39	23.59	17.00	232.0	92.4	92.8	92.3	80.0	74.7	64.5	44.0	184	234	
400	Y	50	10.00		1,479	16.27	14.01	12.21	10.49	114.0	90.4	89.8	88.0	71.6	62.7	49.0	35.5	260	370	
200	YY	50	10.00		1,479	32.54	28.02	24.42	20.98	228.0	90.4	89.8	88.0	71.6	62.7	49.0	35.5	260	370	

without

Mechanical data

Sound level (SPL / SWL) at 60 Hz	61.0 dB(A) / 73.0 dB(A)		Thickener	Polyurea					
Octave Band Center Frequencies Hertz			Safe Stall Time Hot	21 s					
	250	500	1000	2000	4000	8000	Hz	Safe Stall Time Cold	33 s
SPL@3	47.0	53.0	59.0	56.0	47.0	38.0	dB(A)	Frame material	aluminum
Moment of inertia	1.7 Lb-ft ²		Color, paint shade	Standard Paint - RAL7030					
Ext Load Inertia Capability:	75.0 Lb ft ²		Coating (paint finish)	Standard Alkyed + Epoxy (C2)					
Bearings			Ventilation Type						
Bearing DE NDE	6209 ZZ C3 S0		6209 ZZ C3 S0	Method of cooling	TEFC				
Bearing_Type	Ball Bearing		Ball Bearing	Direction of rotation	Bidirectional				
AFBMA:	45BC02JPP30		45BC02JPP30	Fan Material	Polypropylen				
Grease			VFD	CT: 4:1 VT: 20:1					
Capacity	0.5 oz		0.5 oz	Space heaters	without				
Grease Type:	Exxon Mobile EM		Brake:	without					

Terminal box

Lead Wire Connection	9 LEAD - WYE				Terminal box position	(3) F-1, Standard Floor Mount, T. Box LHS
Voltage	L1	L1	L1	Connected together	Material of terminal box	Aluminium
LOW	T1 T7	T2 T8	T3 T9	T4 T5 T6	Cable entry	1.25" NPT
HIGH	T1	T2	T3	T4 T7-T5 T8-T6 T9		

Notes:

I_L/I_N = locked rotor current / current nominal
M_L/M_N = locked rotor torque / torque nominal
M_d/M_N = break down torque / nominal torque

3) Value is valid only for DOL operation with motor design IC411
2) at rated power / at full load

responsible dep. DI MC LVM	technical reference	created by DT Configurator	approved by	<i>Technical data are subject to change! There may be discrepancies between our website and our data sheets.</i>	
	document type datasheet	document status released	customer		
	title 1LE2121-2BB11-4EA3	document number	rev. 01	creation date 2022-04-08 19:31	language en
© Siemens AG 2022				Page 1/1	

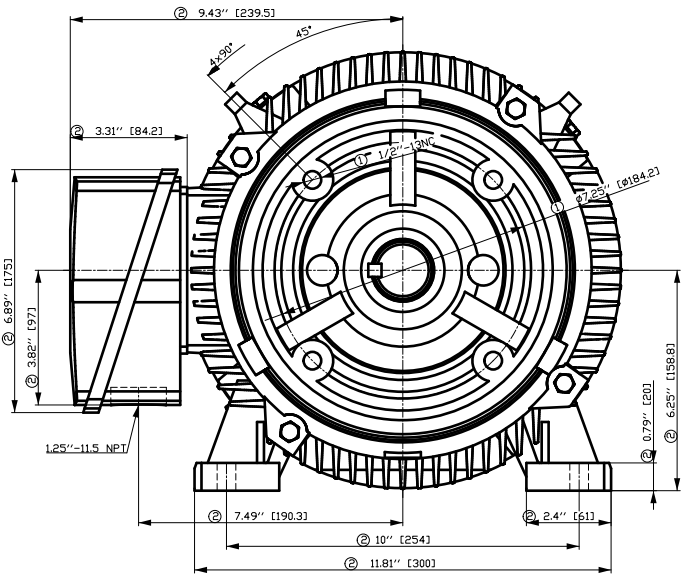

- ① Tolerances according to NEMA std.
- ② All these dimensions corresponding to assemblies and castings shall have a tolerance as per DIN standard 1686-GTB 19.
- ③ Not according to NEMA std.

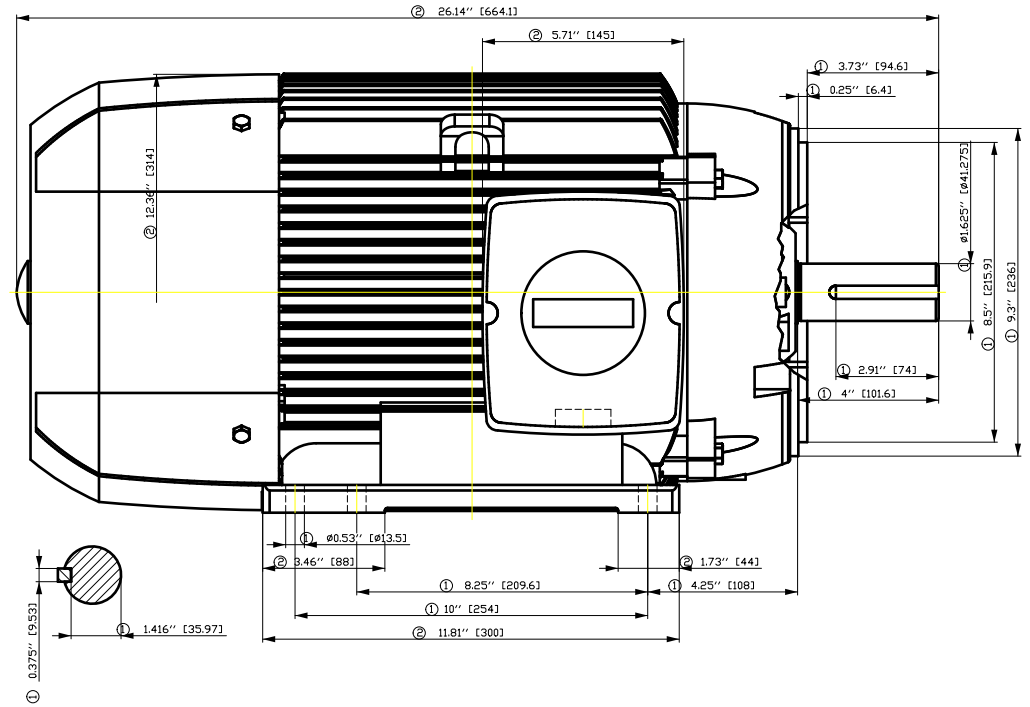

Tolerance	Surface	Material	Weight	Scale
F50GFGFE00FF8 ÖCEH	Author	ÖS	1	1:1
E	Creator	ÖVS		
	Approval	Tæ: ^æ@` } *		
	Department			
	Change Order	MLFB	Doc Type	
	Doc State	I ð BGG	Item No	Paper Size CH
	Revision	Index RS	Doc No	1st Language ^}
				2nd Language æ^
© Siemens AG 2018	Project No	E	Ref No	E
			Sheet	F of F

SIEMENS INDUSTRY, INC.

HP 15 VOLTS < 600V RPM 1800 TYPE GP100A
HZ 60 PHASE 3 FRAME 254T NEMA B

TORQUE & CURRENT VS. SPEED

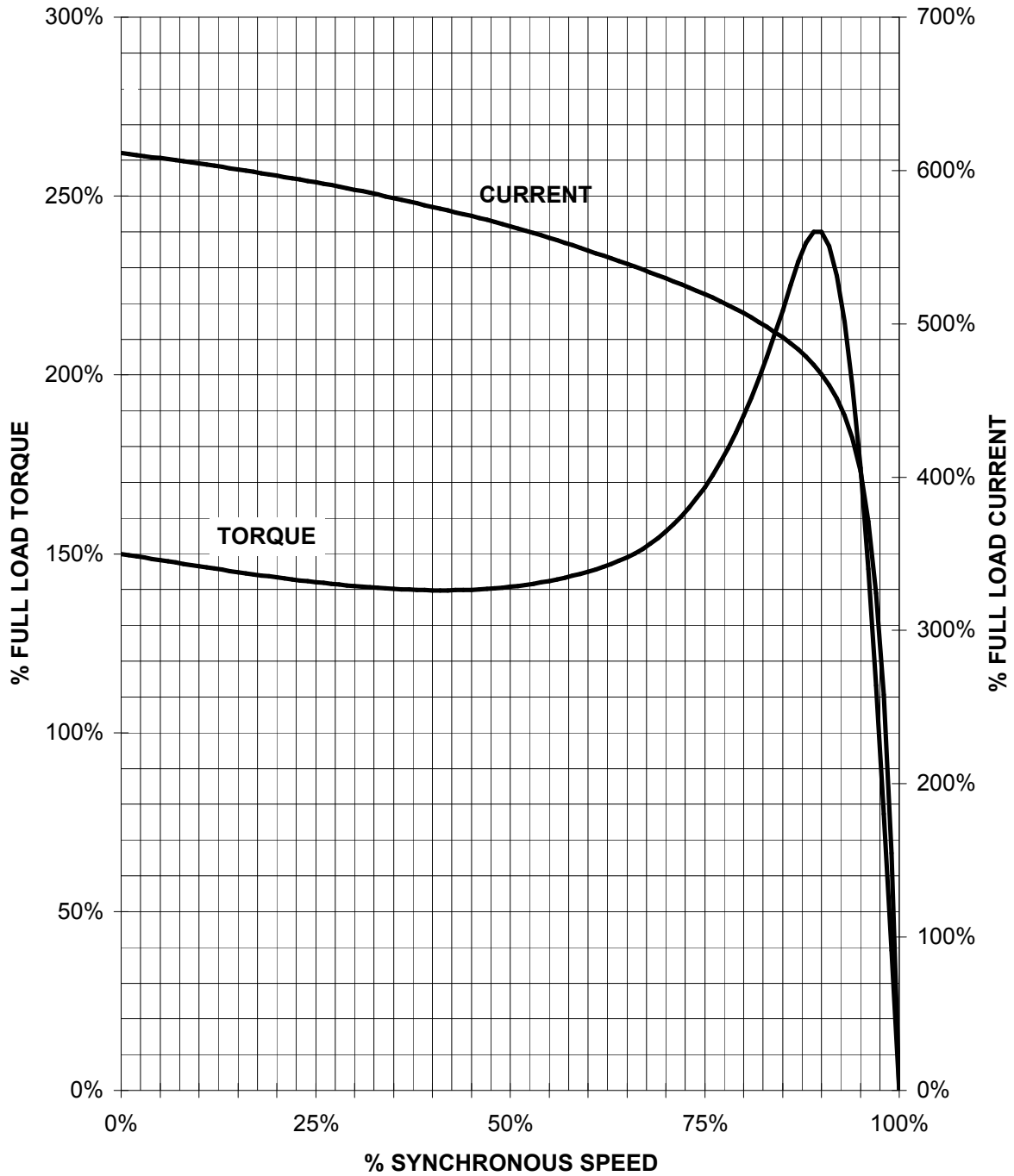

CUSTOMER: _____ ORDER#: _____

15 HP 1800 RPM 254 FRAME 460 VOLTS 3 PHASE NEMA DESIGN B

SIEMENS INDUSTRY, INC.
PERFORMANCE CURVE
GP100A NP

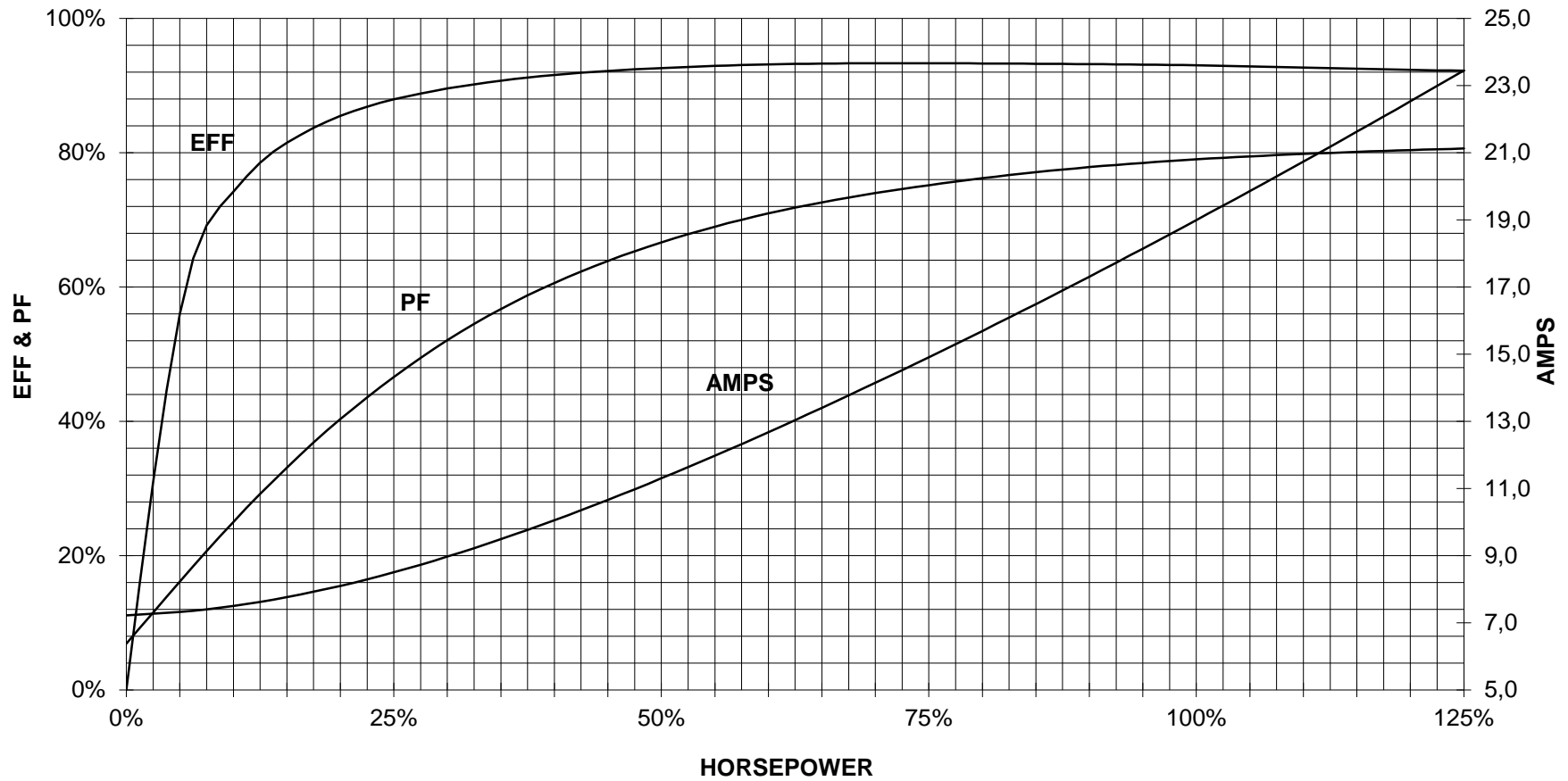

CUSTOMER _____ ORDER # _____ PO # _____

PERFORMANCE BASED ON DESIGN CALCULATIONS. SUBJECT TO CHANGE WITHOUT NOTICE.

REV. 1

Main terminal diagram

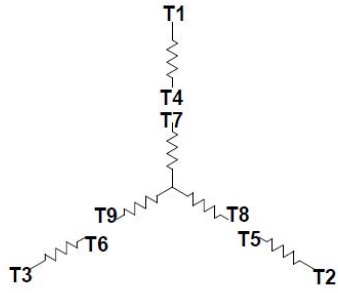

9 LEAD WYE						
Volts	LINES			CONNECTED TOGETHER	CONN.	
	L1	L2	L3			
LOW	T1 T7	T2 T6	T3 T9	T4 T5 T6	YY	
HIGH	T1	T2	T3	T4 T7-T5 T8-T6 T9	Y	

responsible dep. DI MC LVM	technical reference	created by	approved by	Project
SIEMENS	document type Wiring Diagram	document status free		customer
	title 1LE2121-2BB11-4EA3	document number		
© Siemens AG 2019	rev. 01	creation date 12/03/2019	language en	Page 1/1