

# Data sheet for three-phase Squirrel-Cage-Motors SIMOTICS

Motor type: **GP100A** FS: **254T - 6p - 7.5 hp -**

Client order no.	Item-No.	Offer no.
Order no.	Consignment no.	Project
Remarks		

## Electrical data

U [V]	$\Delta/Y$	f [Hz]	P [HP]	P [kW]	n [rpm]	I Load [Amps]					LRC	Nom. Eff Load [%]			Pwr. Factor Load [%]			Torque [lb-ft]	T <sub>A</sub> /T <sub>N</sub> LRT [%]	T <sub>k</sub> /T <sub>N</sub> BDT [%]
						4/4	3/4	1/2	0	4/4		3/4	2/4	4/4	3/4	2/4				
575	Y	60	7.50	5.50	1,200	8.00	6.60	5.30	4.00	50.4	91.0	91.5	91.1	77.2	70.2	58.4	33.0	167	261	

**without**

Frame Type: 254T	Type of constr.: (A) Foot mounted - End shield	Ins. Cl.: Standard Class F Insulation	Motor Prot.: (A) Without Protection	NEMA Des.: B	S.F.: 1.15
Mtr. WT: 186		Temp. Rise Cl.: B	Amb. Temp.: + 40 to -20 °C @1000 m	kVA: H	IP 55

## Mechanical data

Sound level (SPL / SWL) at 60 Hz	55.0 dB(A) / 67.0 dB(A)		Thickener	Polyurea					
Octave Band Center Frequencies Hertz			Safe Stall Time Hot	26 s					
	250	500	1000	2000	4000	8000	Hz	Safe Stall Time Cold	45 s
SPL@3	40.0	42.0	51.0	46.0	51.0	28.0	dB(A)	Frame material	aluminum
Moment of inertia	1.5 Lb-ft <sup>2</sup>		Color, paint shade	Standard Paint - RAL7030					
Ext Load Inertia Capability:	104.0 Lb ft <sup>2</sup>		Coating (paint finish)	Standard Alkyed + Epoxy (C2)					
<b>Bearings</b>			<b>Ventilation Type</b>						
Bearing DE   NDE	6209 ZZ C3 S0		6209 ZZ C3 S0	Method of cooling	TEFC				
Bearing_Type	Ball Bearing		Ball Bearing	Direction of rotation	Bidirectional				
AFBMA:	45BC02JPP30		45BC02JPP30	Fan Material	Polypropylen				
<b>Grease</b>			VFD	CT: 4:1 VT: 20:1					
Capacity	0.5 oz		0.5 oz	Space heaters	without				
Grease Type:	Exxon Mobile EM		Brake:	without					

## Terminal box

Lead Wire Connection	3 LEAD - WYE				Terminal box position	(3) F-1, Standard Floor Mount, T. Box LHS
Voltage	L1	L1	L1	Connected together	Material of terminal box	Aluminium
----	----	----	----	----	Cable entry	1.25" NPT
----	T1	T2	T3	----		

**Notes:**

I<sub>r</sub>/I<sub>N</sub> = locked rotor current / current nominal  
M<sub>r</sub>/M<sub>N</sub> = locked rotor torque / torque nominal  
M<sub>b</sub>/M<sub>N</sub> = break down torque / nominal torque

3) Value is valid only for DOL operation with motor design IC411  
2) at rated power / at full load

responsible dep. DI MC LVM	technical reference	created by DT Configurator	approved by	<i>Technical data are subject to change! There may be discrepancies between software and hardware versions</i>	
	document type datasheet	document status released	customer		
	title 1LE2121-2BC11-3AA3	document number			
© Siemens AG 2022	rev. 01	creation date 2022-04-08 19:35	language en	Page 1/1	

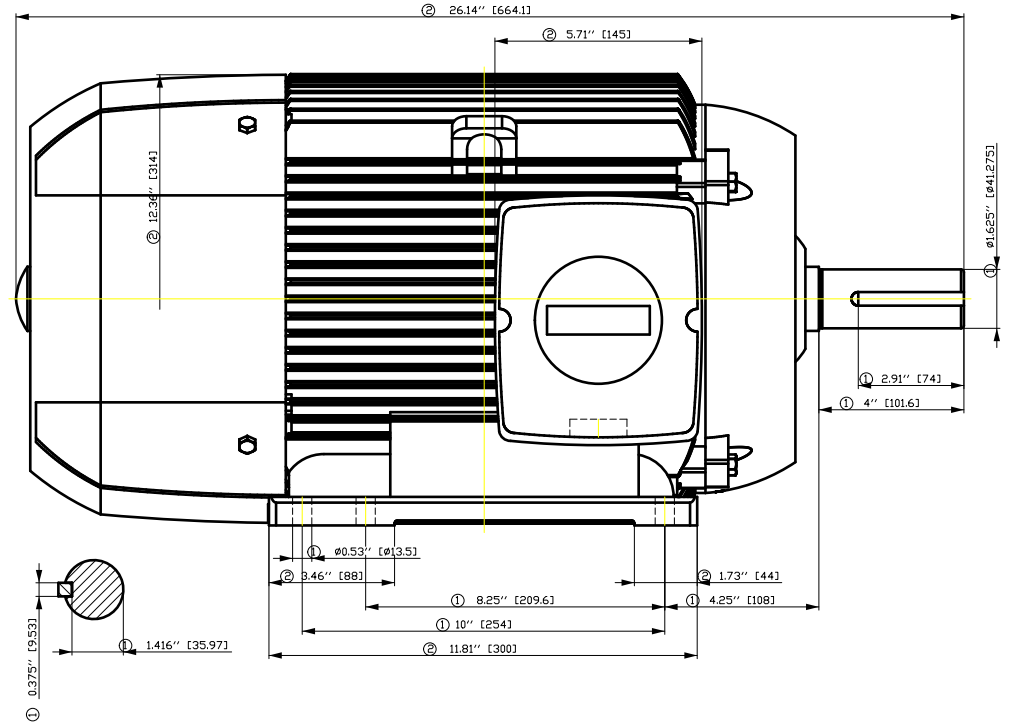
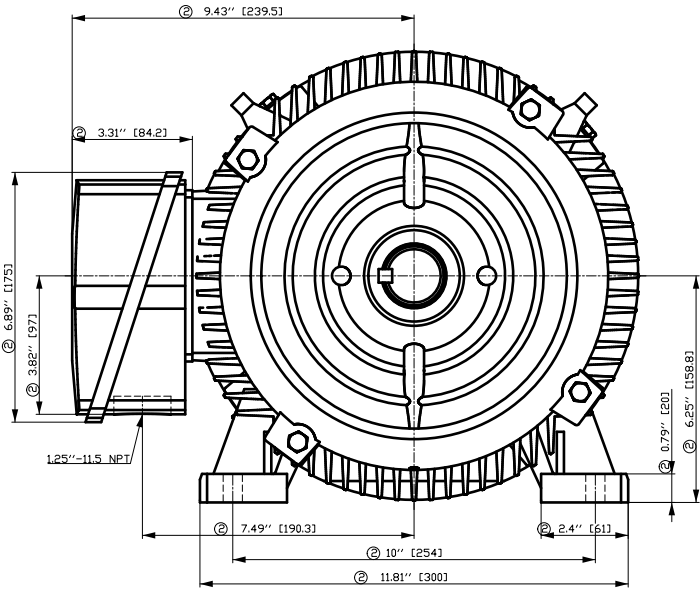

- ① Tolerances according to NEMA std.
- ② All these dimensions corresponding to assemblies and castings shall have a tolerance as per DIN standard 1686-GTB 19.
- ③ Not according to NEMA std.

Tolerance	Surface	Material	Weight	Scale
F50GF6E00FFH00H	Author	ÖS	1.625" [41.275]	1:1
E	Creator	Tæ: ^æ@` } *	2.91" [74]	
	Approval		4" [101.6]	
	Department			
	Change Order	MLFB		
	Doc. State	I 0000		
<b>SIEMENS</b>	Revision	Index		
© Siemens AG 2018	Project No	E		
	Item No			
	Doc No			
	1st Language	^		
	2nd Language	â^		
	Sheet	F of F		

# SIEMENS INDUSTRY, INC.

HP 7,5 VOLTS < 600V RPM 1200 TYPE GP100A  
HZ 60 PHASE 3 FRAME 254T NEMA B

## TORQUE & CURRENT VS. SPEED

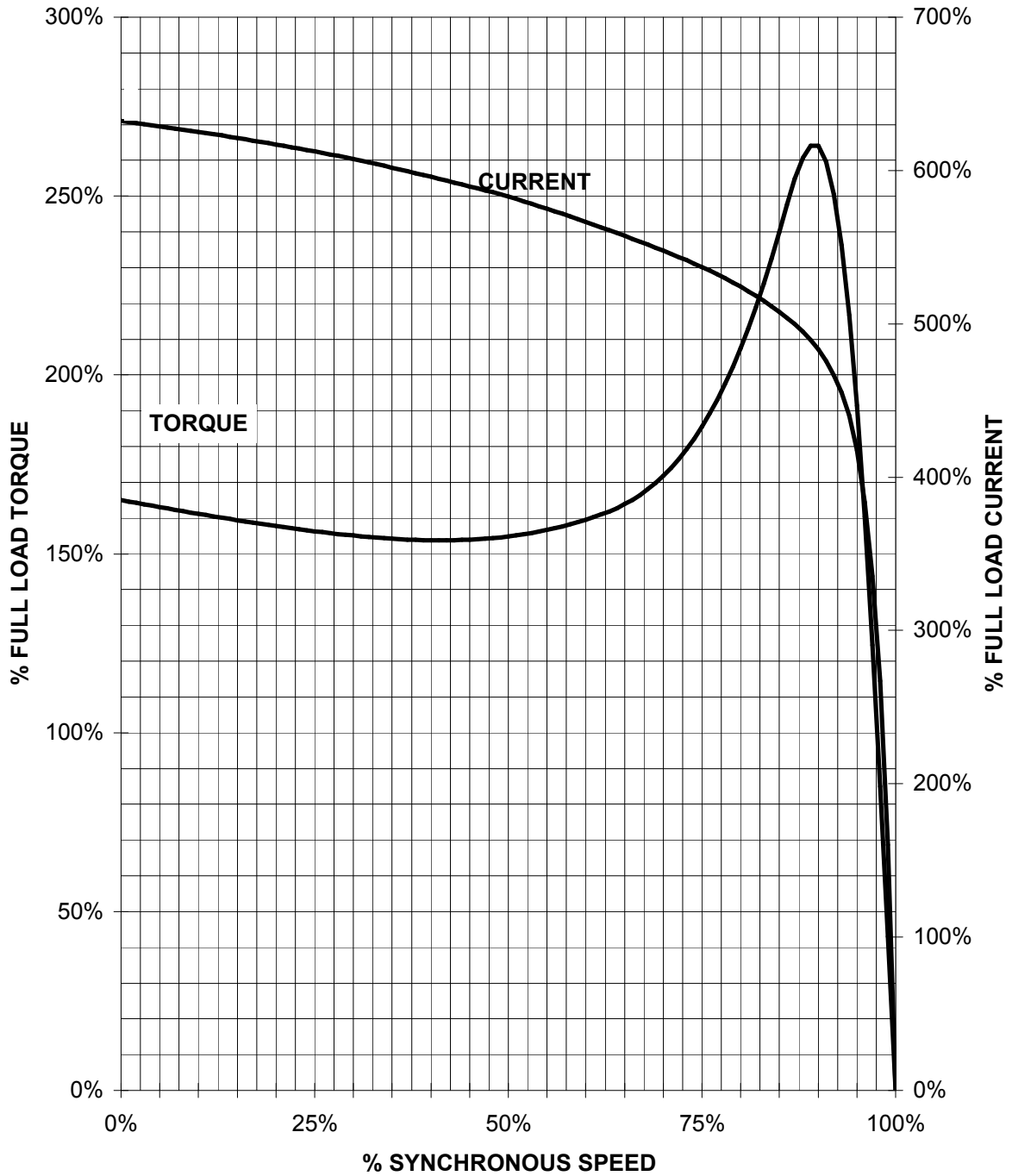

CUSTOMER: \_\_\_\_\_ ORDER#: \_\_\_\_\_

7.5 HP 1200 RPM 254 FRAME 575 VOLTS 3 PHASE NEMA DESIGN B

**SIEMENS INDUSTRY, INC.**  
**PERFORMANCE CURVE**  
**GP100A NP**

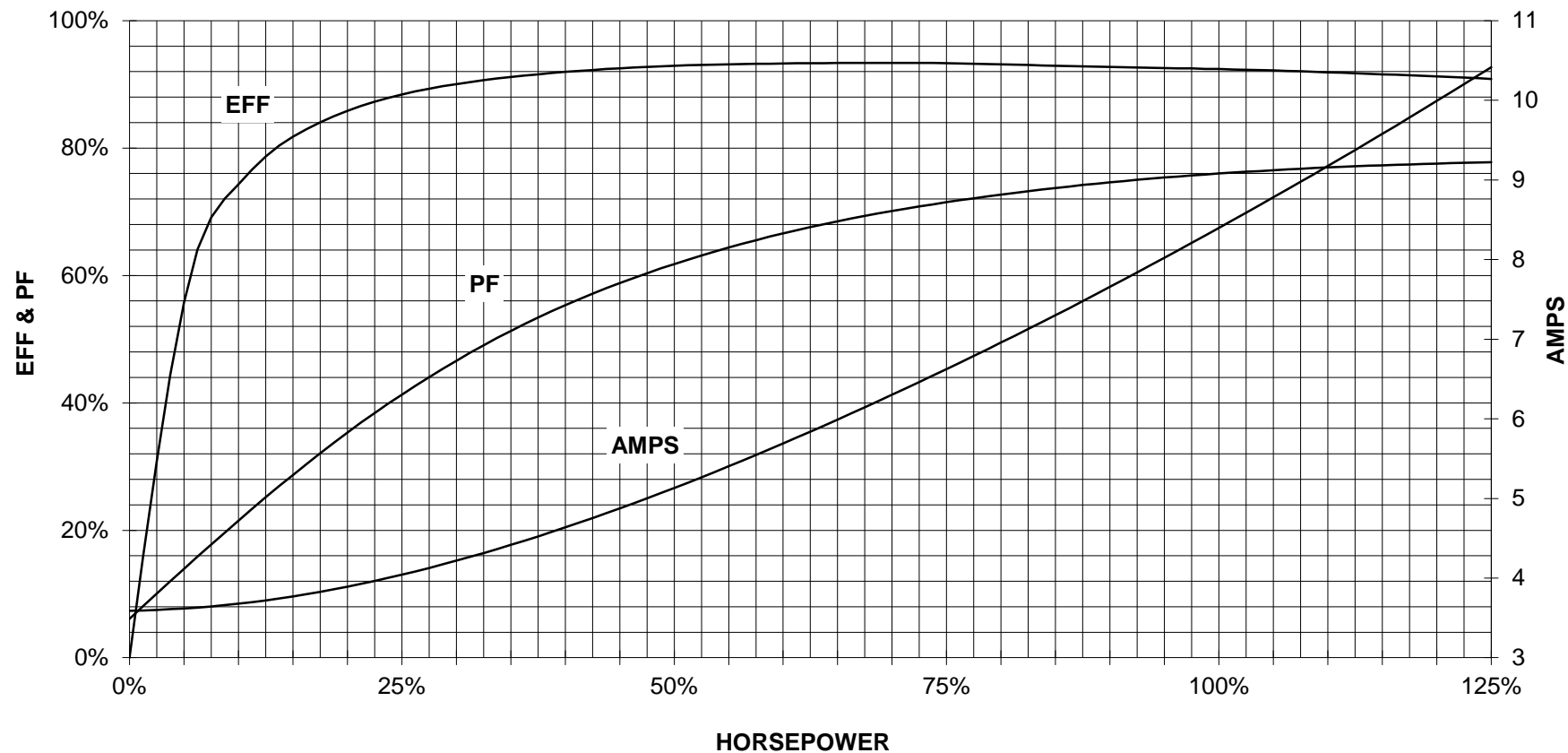

CUSTOMER \_\_\_\_\_ ORDER # \_\_\_\_\_ PO # \_\_\_\_\_

PERFORMANCE BASED ON DESIGN CALCULATIONS. SUBJECT TO CHANGE WITHOUT NOTICE.

REV. 1

Main terminal diagram



3 LEAD WYE			
LINES			CONN.
L1	L2	L3	
T1	T2	T3	Y

responsible dep.  
DI MC LVM

technical reference

created by

approved by

Project

**SIEMENS**

document type  
Wiring Diagram

title  
1LE2121-2BC11-3AA3

document status  
free

document number

customer