

Data sheet for three-phase Squirrel-Cage-Motors SIMOTICS

Motor type: **GP100A** FS: 254T - 6p - 7.5 hp -

Client order no.	Item-No.	Offer no.
Order no.	Consignment no.	Project
Remarks		

Electrical data

U [V]	Δ/Y	f [Hz]	P [HP]	P [kW]	n [rpm]	I Load [Amps]					LRC	Nom. Eff Load [%]			Pwr. Factor Load [%]			Torque [lb-ft]	T _A /T _N LRT [%]	T _k /T _N BDT [%]
						4/4	3/4	1/2	0	4/4		3/4	2/4	4/4	3/4	2/4				
575	Y	60	7.50	5.50	1,200	8.00	6.60	5.30	4.00	50.4	91.0	91.5	91.1	77.2	70.2	58.4	33.0	167	261	
Frame Type: 254T		Type of constr.: (E) Foot mounted - C-Face				Ins. Cl.:Standard Class F Insulation		Motor Prot.:(A) Without Protection			NEMA Des.: B		S.F.: 1.15							
Mtr. WT:186						Temp. Rise Cl.: B		Amb. Temp.: + 40 to -20 °C @1000 m			kVA: H		IP 55							

Mechanical data

Sound level (SPL / SWL) at 60 Hz	55.0 dB(A) / 67.0 dB(A)		Thickener	Polyurea					
Octave Band Center Frequencies Hertz			Safe Stall Time Hot	26 s					
	250	500	1000	2000	4000	8000	Hz	Safe Stall Time Cold	45 s
SPL@3	40.0	42.0	51.0	46.0	51.0	28.0	dB(A)	Frame material	aluminum
Moment of inertia	1.5 Lb-ft ²		Color, paint shade	Standard Paint - RAL7030					
Ext Load Inertia Capability:	104.0 Lb ft ²		Coating (paint finish)	Standard Alkyed + Epoxy (C2)					
Bearings			Ventilation Type						
Bearing DE NDE	6209 ZZ C3 S0		6209 ZZ C3 S0						
Bearing_Type	Ball Bearing		Ball Bearing						
AFBMA:	45BC02JPP30		45BC02JPP30						
Grease			Method of cooling						
Capacity	0.5 oz		0.5 oz						
Grease Type:	Exxon Mobile EM		VFD						
			Space heaters						
			Brake:						

Terminal box

Lead Wire Connection		3 LEAD - WYE			Terminal box position	(3) F-1, Standard Floor Mount, T. Box LHS
Voltage	L1	L1	L1	Connected together	Material of terminal box	Aluminium
----	----	----	----	----	Cable entry	1.25" NPT
----	T1	T2	T3	----		

Notes:

I_r/I_N = locked rotor current / current nominal
M_r/M_N = locked rotor torque / torque nominal
M_b/M_N = break down torque / nominal torque

3) Value is valid only for DOL operation with motor design IC411
2) at rated power / at full load

responsible dep. DI MC LVM	technical reference	created by DT Configurator	approved by	<i>Technical data are subject to change! There may be discrepancies between software and hardware versions</i>	
	document type datasheet	document status released		customer	
	title 1LE2121-2BC11-3EA3	document number			
© Siemens AG 2022	rev. 01	creation date 2022-04-08 19:36	language en	Page 1/1	

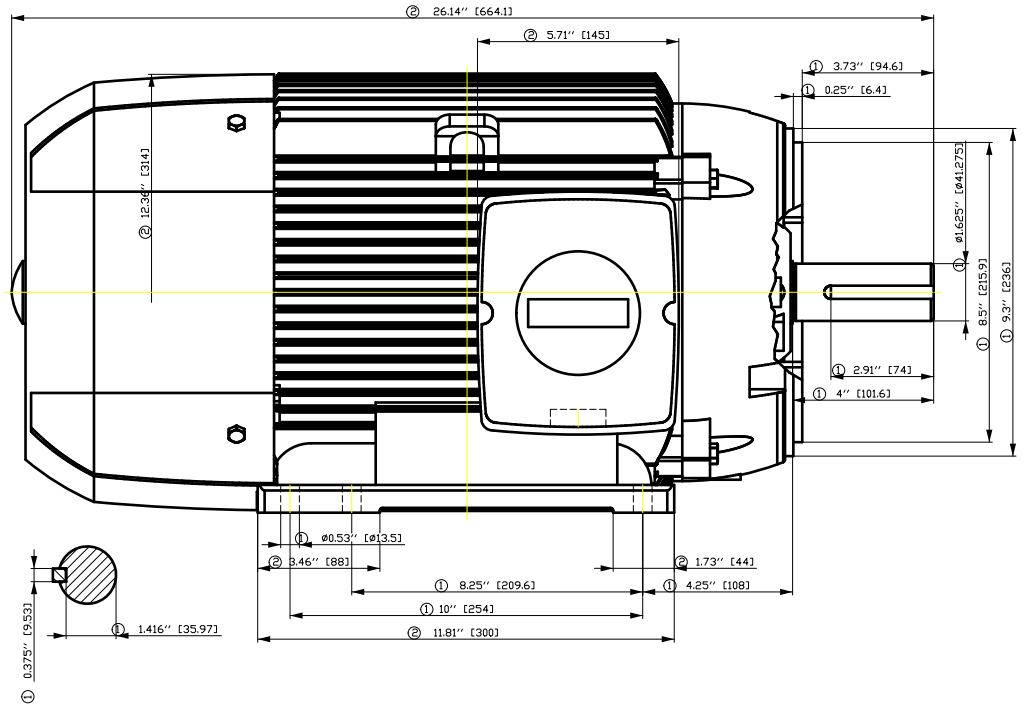
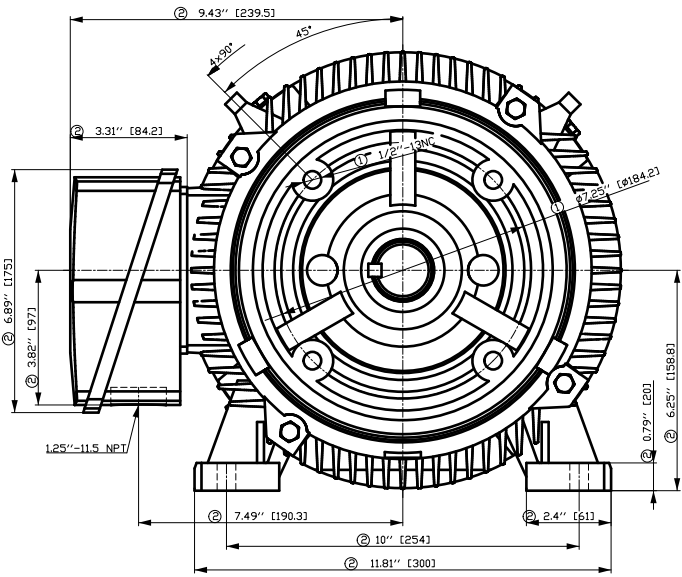

- ① Tolerances according to NEMA std.
- ② All these dimensions corresponding to assemblies and castings shall have a tolerance as per DIN standard 1686-GTB 19.
- ③ Not according to NEMA std.

Tolerance	Surface	Material	Weight	Scale
F50GFGE00FFEH0EH	Author	ÖS	E	
E	Creator			
	Approval			
	Department			
	Change Order	MFB		Doc Type
	Doc. State	I 0000	Item No	Paper Size
	Revision	Index RS	Doc No	1st Language
				2nd Language
© Siemens AG 2018	Project No	E	Ref No	E
				Sheet F of F

SIEMENS INDUSTRY, INC.

HP 7,5 VOLTS < 600V RPM 1200 TYPE GP100A
HZ 60 PHASE 3 FRAME 254T NEMA B

TORQUE & CURRENT VS. SPEED

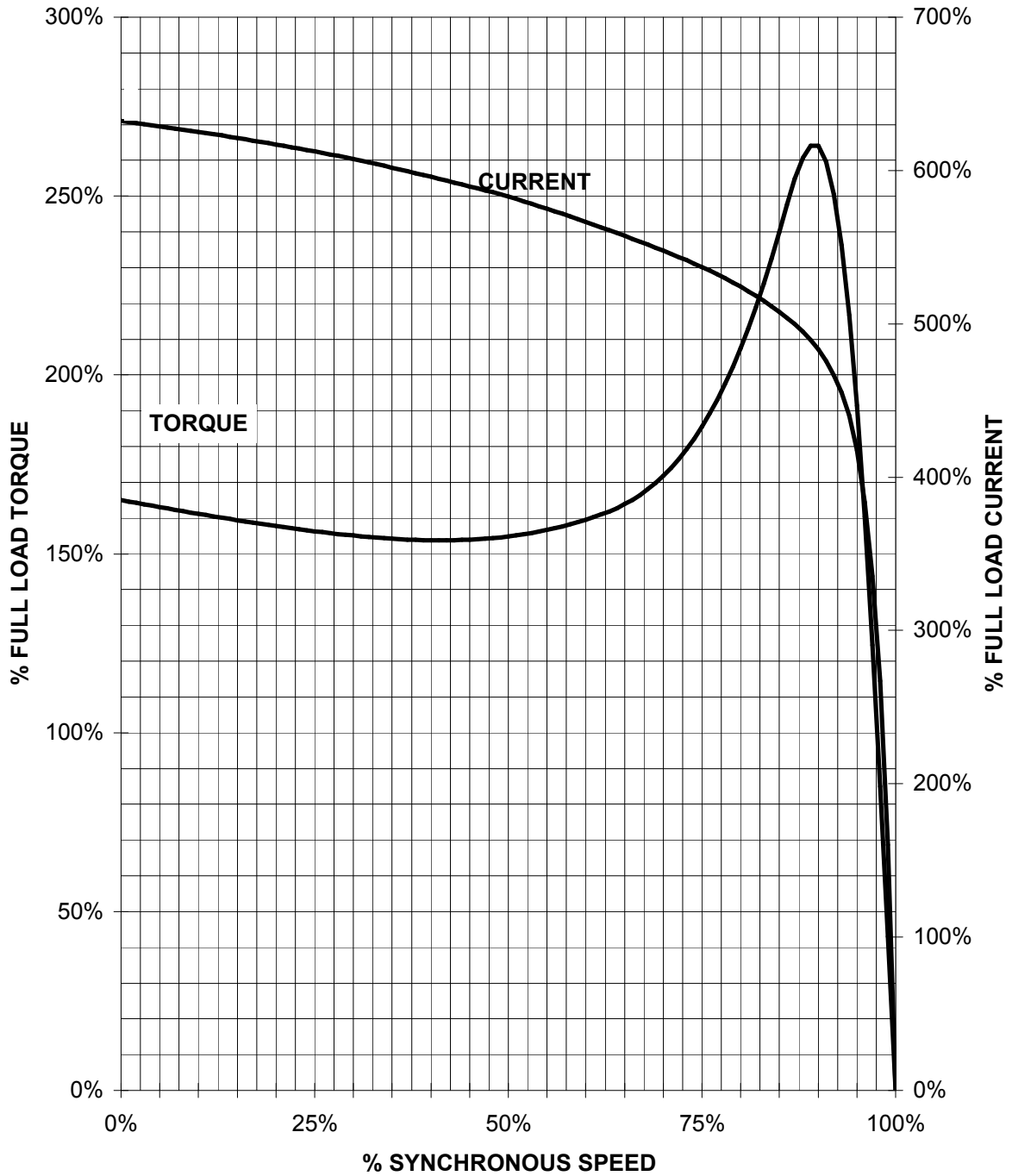

CUSTOMER: _____ ORDER#: _____

7.5 HP 1200 RPM 254 FRAME 575 VOLTS 3 PHASE NEMA DESIGN B

SIEMENS INDUSTRY, INC.
PERFORMANCE CURVE
GP100A NP

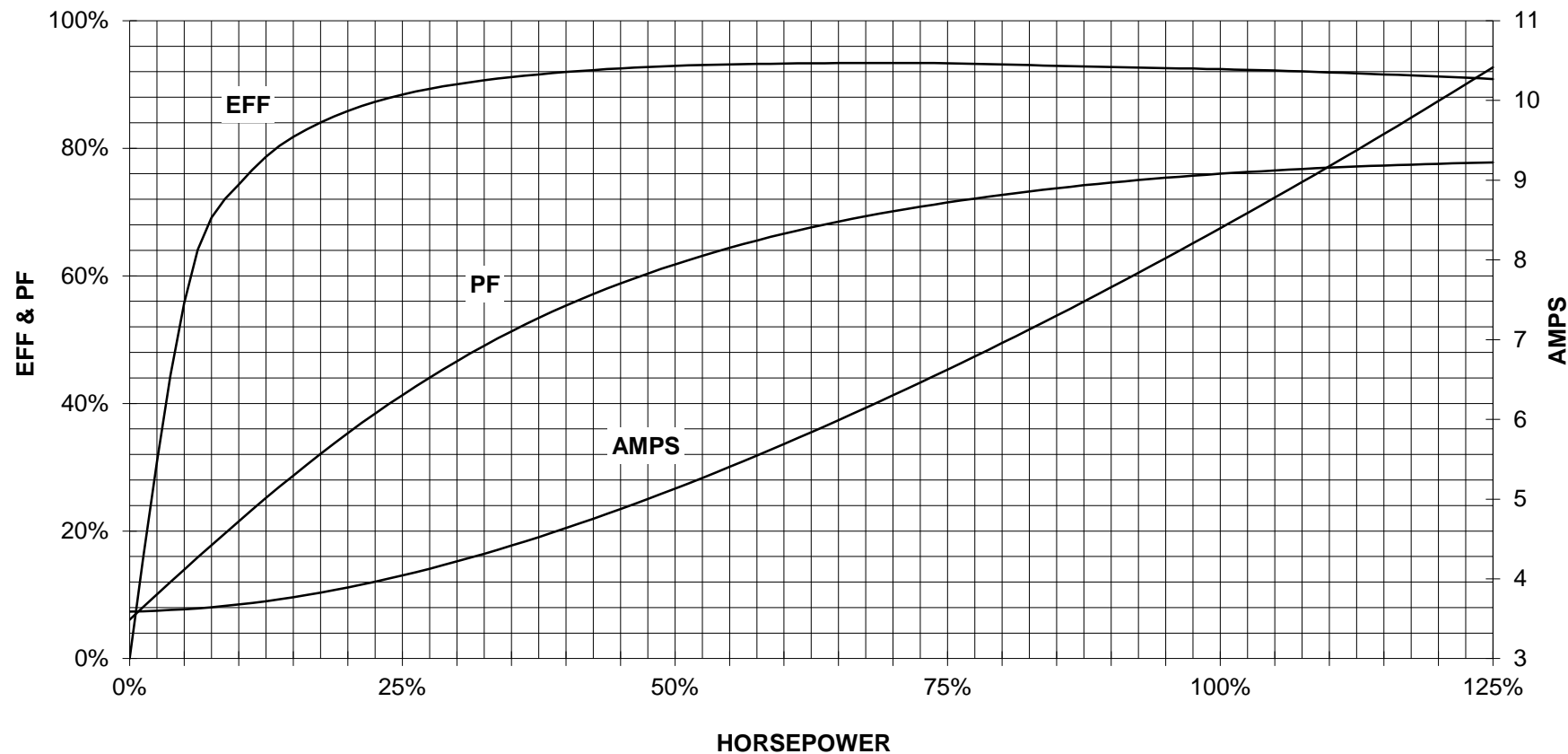

CUSTOMER _____ ORDER # _____ PO # _____

PERFORMANCE BASED ON DESIGN CALCULATIONS. SUBJECT TO CHANGE WITHOUT NOTICE.

REV. 1

Main terminal diagram



3 LEAD WYE			
LINES			CONN.
L1	L2	L3	
T1	T2	T3	

responsible dep.
DI MC LVM

technical reference

created by

approved by

Project

SIEMENS

document type
Wiring Diagram

title
1LE2121-2BC11-3EA3

document status
free

document number

customer