

# Data sheet for three-phase Squirrel-Cage-Motors SIMOTICS

Motor type: **GP100A** FS: 254T - 6p - 7.5 hp -

Client order no.	Item-No.	Offer no.
Order no.	Consignment no.	Project
Remarks		

## Electrical data

U [V]	$\Delta/Y$	f [Hz]	P [HP]	P [kW]	n [rpm]	I Load [Amps]					LRC	Nom. Eff Load [%]			Pwr. Factor Load [%]			Torque [lb-ft]	T <sub>A</sub> /T <sub>N</sub> LRT [%]	T <sub>k</sub> /T <sub>N</sub> BDT [%]
						4/4	3/4	1/2	0	4/4		3/4	2/4	4/4	3/4	2/4				
460	Y	60	7.50	5.50	1,200	10.00	8.20	6.60	5.00	63.0	91.0	91.5	91.1	77.2	70.2	58.4	33.0	167	261	
230	YY	60	7.50	5.50	1,200	20.00	16.40	13.20	10.00	126.0	91.0	91.5	91.1	77.2	70.2	58.4	33.0	167	261	
400	Y	50	5.00		984	8.62	7.45	6.50	5.72	64.1	86.5	86.2	84.6	67.9	59.2	46.0	26.7	254	380	
200	YY	50	5.00		984	17.24	14.90	13.00	11.44	128.2	86.5	86.2	84.6	67.9	59.2	46.0	26.7	254	380	

without

## Mechanical data

Sound level (SPL / SWL) at 60 Hz	55.0 dB(A) / 67.0 dB(A)	Thickener	Polyurea
Octave Band Center Frequencies Hertz		Safe Stall Time Hot	26 s
250	500	1000	2000
4000	8000	Hz	
SPL@3	40.0	42.0	51.0
	46.0	51.0	28.0
Moment of inertia	1.5 Lb-ft <sup>2</sup>	Frame material	aluminum
Ext Load Inertia Capability:	104.0 Lb ft <sup>2</sup>	Color, paint shade	Standard Paint - RAL7030
<b>Bearings</b>		Coating (paint finish)	Standard Alkyed + Epoxy (C2)
Bearing DE   NDE	6209 ZZ C3 S0	<b>Ventilation Type</b>	
Bearing_Type	Ball Bearing	Method of cooling	TEFC
AFBMA:	45BC02JPP30	Direction of rotation	Bidirectional
<b>Grease</b>		Fan Material	Polypropylen
Capacity	0.5 oz	VFD	CT: 4:1 VT: 20:1
Grease Type:	Exxon Mobile EM	Space heaters	without
		Brake:	without

## Terminal box

Lead Wire Connection	9 LEAD - WYE	Terminal box position	(3) F-1, Standard Floor Mount, T. Box LHS
Voltage	L1 L1 L1 Connected together	Material of terminal box	Aluminium
LOW	T1 T7 T2 T8 T3 T9 T4 T5 T6	Cable entry	1.25" NPT
HIGH	T1 T2 T3 T4 T7-T5 T8-T6 T9		

## Notes:

I<sub>L</sub>/I<sub>N</sub> = locked rotor current / current nominal  
M<sub>L</sub>/M<sub>N</sub> = locked rotor torque / torque nominal  
M<sub>d</sub>/M<sub>N</sub> = break down torque / nominal torque

3) Value is valid only for DOL operation with motor design IC411  
2) at rated power / at full load

responsible dep.	technical reference	created by	approved by	<i>Technical data are subject to change! There may be discrepancies between software and hardware versions</i>	
DI MC LVM		DT Configurator			
	document type	document status	customer		
	datasheet	released			
	title	document number			
	1LE2121-2BC11-4EA3				
© Siemens AG 2022		rev.	creation date	language	Page
		01	2022-04-08 19:37	en	1/1

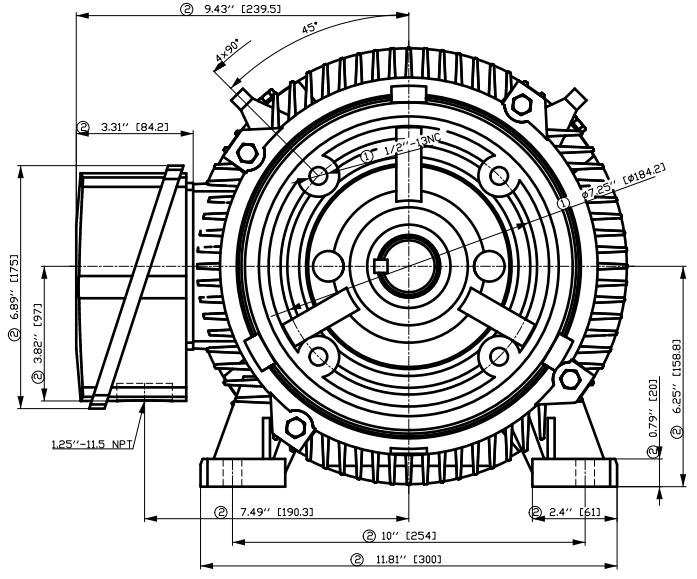

- ① Tolerances according to NEMA std.
- ② All these dimensions corresponding to assemblies and castings shall have a tolerance as per DIN standard 1686-GTB 19.
- ③ Not according to NEMA std.

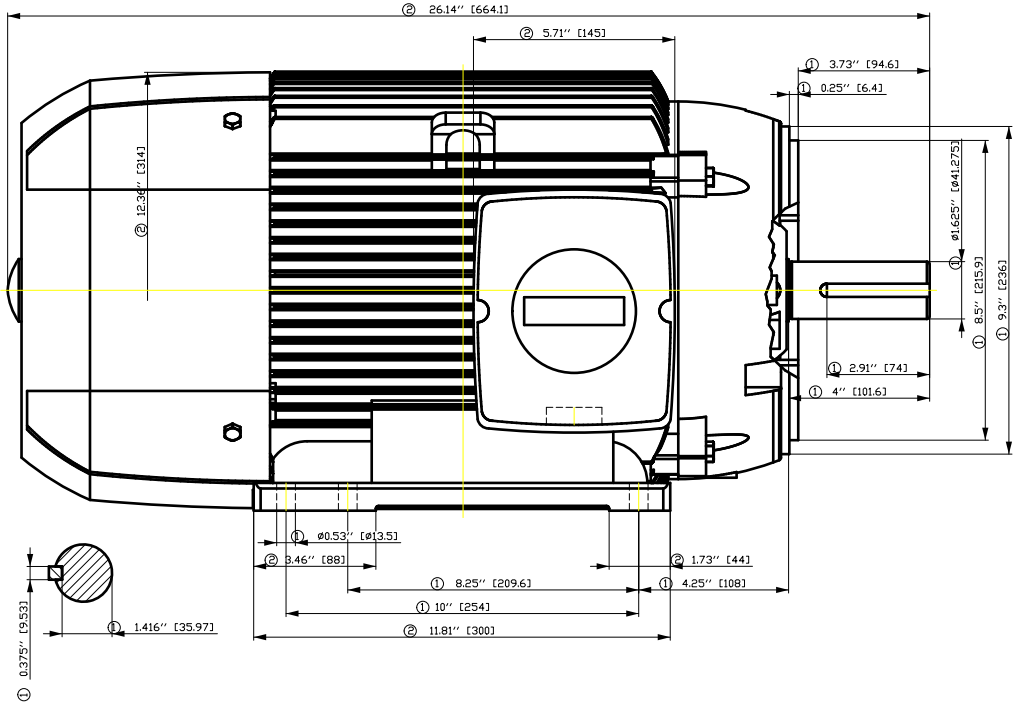

Tolerance	Surface	Material	Weight	Scale
F5ÖGFGFßÖÖFFß ÖCEH	Author	Öv ^ } . ð } æ ð ! æ ð *	£	{ {
£	Creator	ÖVS		
	Approval	T æ : ^ æ @ } }		
	Department			
	Change Order	MFB	Doc Type	/
<b>SIEMENS</b>	Doc. State	I ð BGG	Item No	Paper Size
© Siemens AG 2018	Revision	Index	Doc No	1st Language ^ } 2nd Language ð ^
	Project No	£	Ref No	£
			Sheet	F of F

# SIEMENS INDUSTRY, INC.

HP 7,5 VOLTS < 600V RPM 1200 TYPE GP100A  
HZ 60 PHASE 3 FRAME 254T NEMA B

## TORQUE & CURRENT VS. SPEED

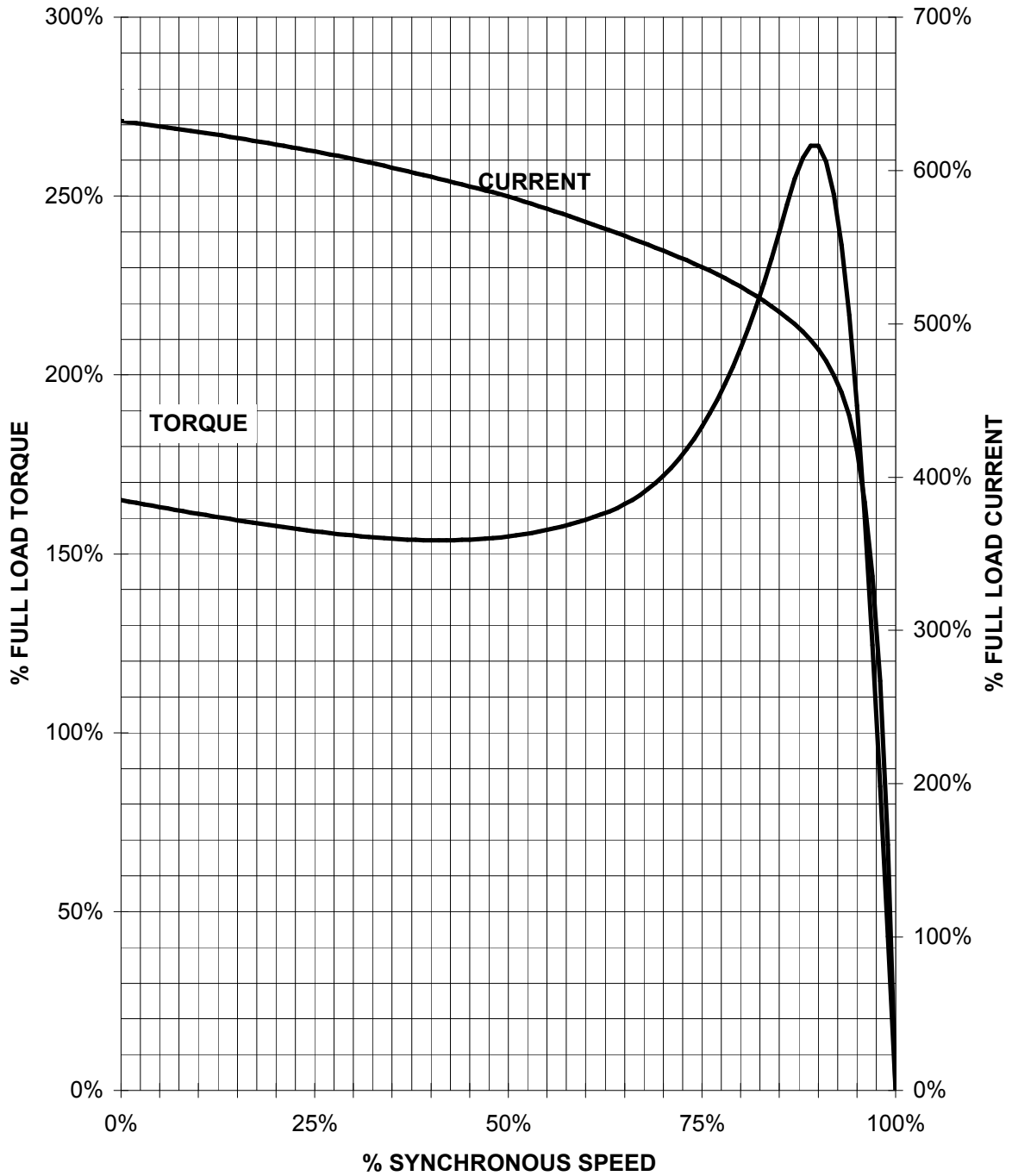

CUSTOMER: \_\_\_\_\_ ORDER#: \_\_\_\_\_

7.5 HP 1200 RPM 254 FRAME 460 VOLTS 3 PHASE NEMA DESIGN B

**SIEMENS INDUSTRY, INC.**  
**PERFORMANCE CURVE**  
**GP100A NP**

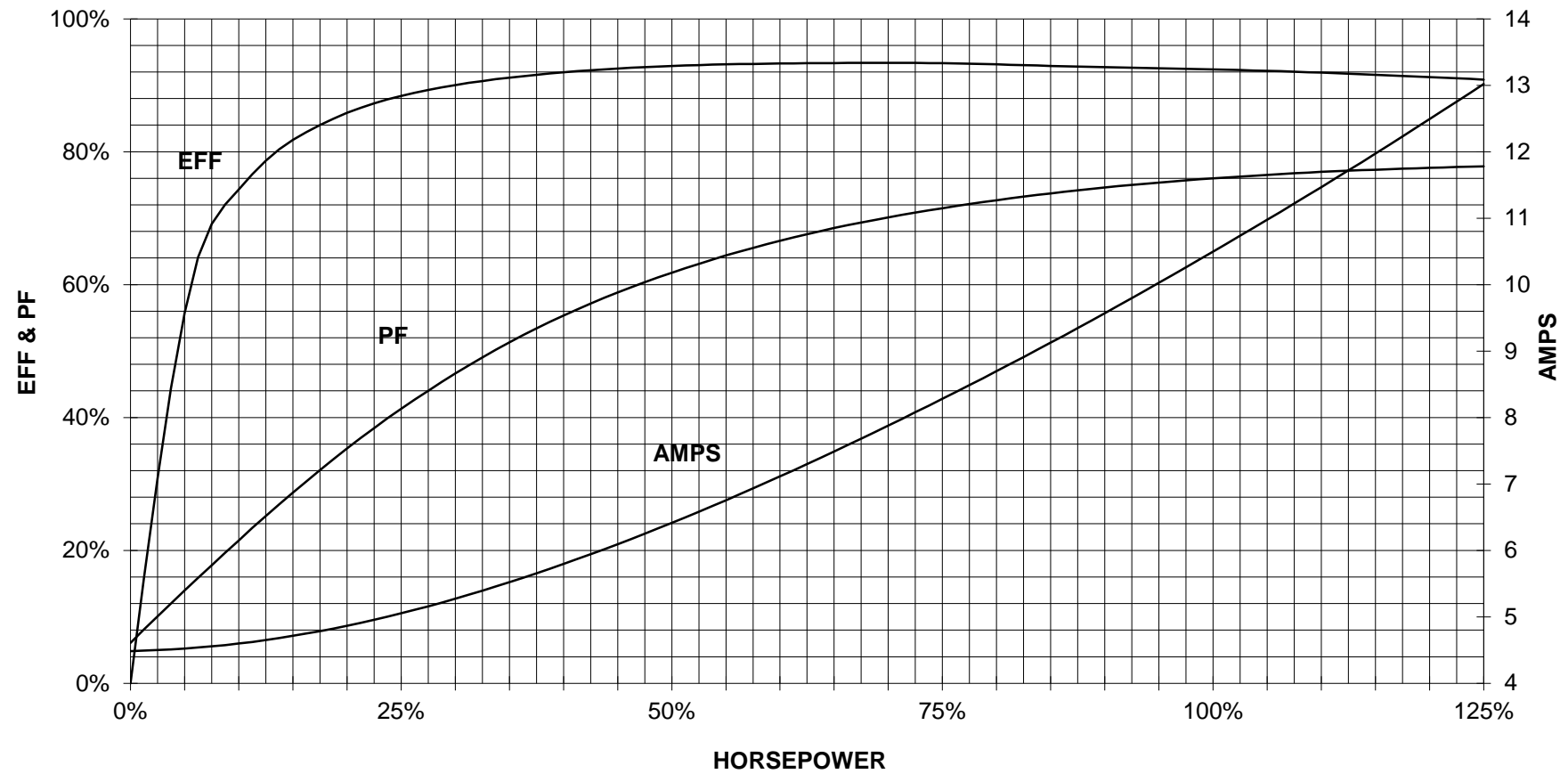

CUSTOMER \_\_\_\_\_ ORDER # \_\_\_\_\_ PO # \_\_\_\_\_

PERFORMANCE BASED ON DESIGN CALCULATIONS. SUBJECT TO CHANGE WITHOUT NOTICE.

REV. 1

Main terminal diagram



9 LEAD WYE						
Volts	LINES			CONNECTED TOGETHER	CONN.	
	L1	L2	L3			
LOW	T1 T7	T2 T6	T3 T9	T4 T5 T6	YY	
HIGH	T1	T2	T3	T4 T7-T5 T8-T6 T9	Y	

responsible dep. DI MC LVM	technical reference	created by	approved by	Project
<b>SIEMENS</b>	document type Wiring Diagram	document status free		customer
	title 1LE2121-2BC11-4EA3	document number		
© Siemens AG 2019	rev. 01	creation date 12/03/2019	language en	Page 1/1