

# Data sheet for three-phase Squirrel-Cage-Motors SIMOTICS

Motor type: **GP100** FS: **145T - 2p - 2 hp -**

Client order no.	Item-No.	Offer no.
Order no.	Consignment no.	Project
Remarks		

## Electrical data

U [V]	$\Delta/Y$	f [Hz]	P [HP]	P [kW]	n [rpm]	I Load [Amps]					LRC	Nom. Eff Load [%]			Pwr. Factor Load [%]			Torque [lb-ft]	T <sub>A</sub> /T <sub>N</sub> LRT [%]	T <sub>k</sub> /T <sub>N</sub> BDT [%]
						4/4	3/4	1/2	0	4/4		3/4	2/4	4/4	3/4	2/4				
575	Y	60	2.00	1.50	3,600	2.00	1.60	1.30	1.00	18.4	85.5	85.7	84.0	87.6	81.3	69.0	2.9	255	431	

Frame Type: 145T	Type of constr.: ( G ) Round body - C-Face	Ins. Cl.: Standard Class F Insulation	Motor Prot.: (A) Without Protection	NEMA Des.: B	S.F.: 1.15
Mtr. WT: 55		Temp. Rise Cl.: B	Amb. Temp.: + 40 to -20 °C @1000 m	kVA: L	IP 55

## Mechanical data

Sound level (SPL / SWL) at 60 Hz	64.0 dB(A) / 76.0 dB(A)							Thickener	Polyurea
Octave Band Center Frequencies Hertz									
	250	500	1000	2000	4000	8000	Hz	Safe Stall Time Hot	13 s
SPL@3	44.0	52.0	62.0	59.0	54.0	46.0	dB(A)	Safe Stall Time Cold	18 s
Moment of inertia	0.1 Lb-ft <sup>2</sup>							Frame material	cast iron
Ext Load Inertia Capability:	24.0 Lb ft <sup>2</sup>							Color, paint shade	Standard Paint - RAL7030
<b>Bearings</b>								Coating (paint finish)	Standard Alkyed + Epoxy (C2)
Bearing DE   NDE	6205 ZZ C3 S0			6205 ZZ C3 S0			<b>Ventilation Type</b>		
Bearing_Type	Ball Bearing			Ball Bearing			Method of cooling	TEFC	
AFBMA:	25BC02JPP30			25BC02JPP30			Direction of rotation	Bidirectional	
<b>Grease</b>								Fan Material	Polypropylen
Capacity	0.1 oz			0.1 oz			VFD	CT: 4:1 VT: 20:1	
Grease Type:	Exxon Mobile EM							Space heaters	without
								Brake:	without

## Terminal box

Lead Wire Connection	3 LEAD - WYE				Terminal box position	(3) F-1, Standard Floor Mount, T. Box LHS
Voltage	L1	L1	L1	Connected together	Material of terminal box	Aluminium
----	----	----	----	----	Cable entry	.75" NPT
----	T1	T2	T3	----		

**Notes:**  
 I<sub>L</sub>/I<sub>N</sub> = locked rotor current / current nominal  
 M<sub>L</sub>/M<sub>N</sub> = locked rotor torque / torque nominal  
 M<sub>B</sub>/M<sub>N</sub> = break down torque / nominal torque  
 3) Value is valid only for DOL operation with motor design IC411  
 2) at rated power / at full load

responsible dep. DI MC LVM	technical reference	created by DT Configurator	approved by	<i>Technical data are subject to change! There may be discrepancies between software and hardware versions</i>			
	document type datasheet	document status released		customer			
	title 1LE2221-1AA31-3GA3	document number					
© Siemens AG 2022	rev. 01	creation date 2022-04-08 02:57	language en	Page 1/1			

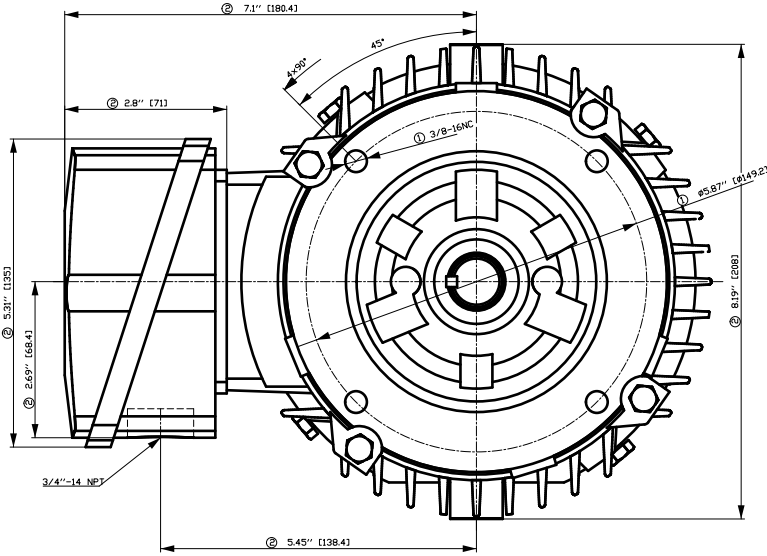

- ① Tolerances according to NEMA std.
- ② All these dimensions corresponding to assemblies and castings shall have a tolerance as per DIN standard 1686-GTB 19.
- ③ Not according to NEMA std.

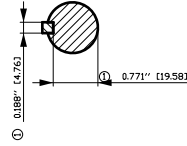
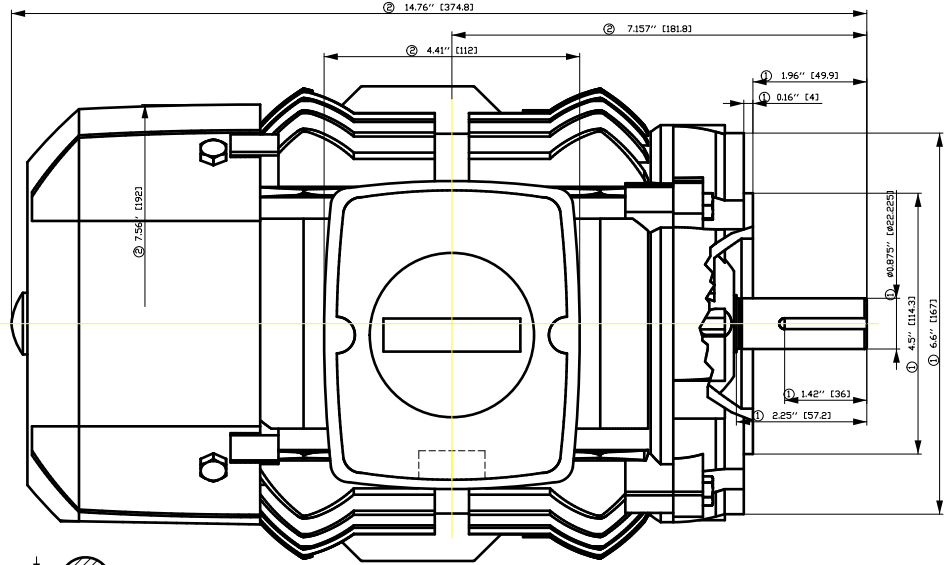

Tolerance	Surface	Material	Weight	Scale
F50GGF-EH-FH-ÖEH	Author	ÖS Tae: ^@~ }	E	1:1
E	Creator			
	Approval			
	Department	MFB		
	Change Order			
	Doc. State	I ð ÖG		Paper Size CH
	Revision	Index RS		1st Language ^
				2nd Language â
© Siemens AG	2018	Project No E	Ref No E	Sheet F of F

# SIEMENS INDUSTRY, INC.

HP 2 VOLTS < 600V RPM 3600 TYPE GP100  
HZ 60 PHASE 3 FRAME 145T NEMA B

## TORQUE & CURRENT VS. SPEED

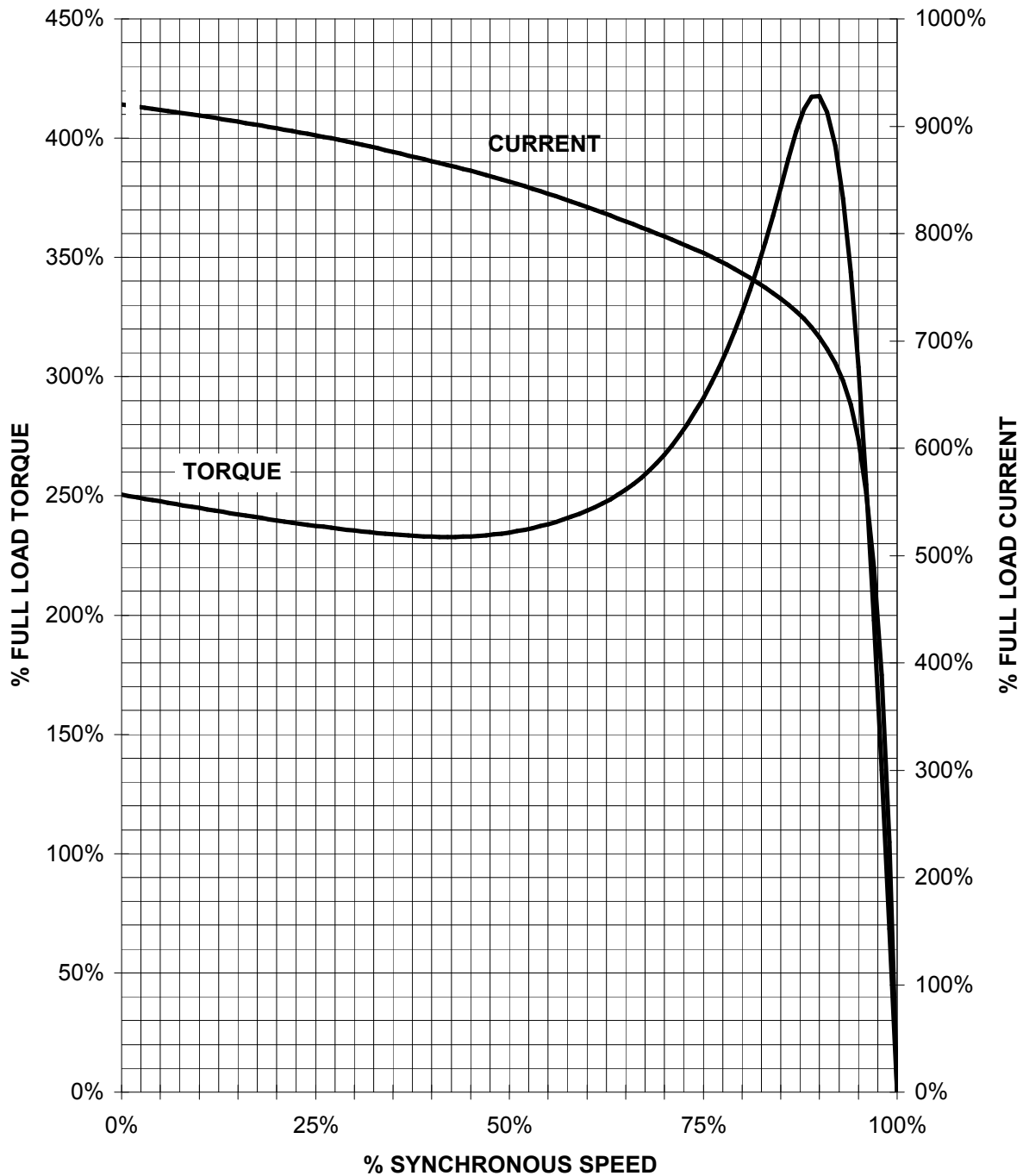

CUSTOMER: \_\_\_\_\_ ORDER#: \_\_\_\_\_

2 HP 3600 RPM 145T FRAME 575 VOLTS 3 PHASE NEMA DESIGN B

**SIEMENS INDUSTRY, INC.**  
**PERFORMANCE CURVE**  
**GP100**

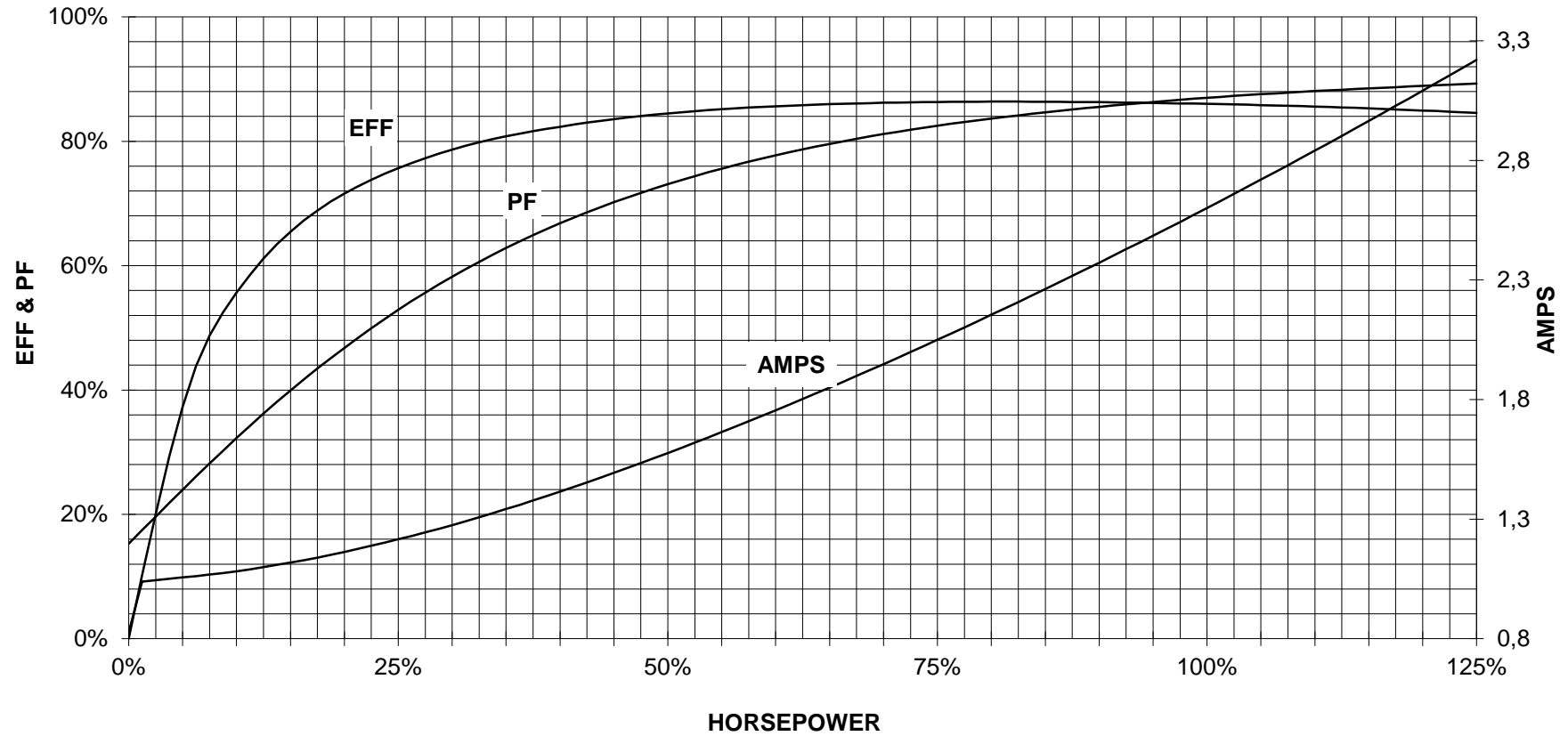

CUSTOMER \_\_\_\_\_ ORDER # \_\_\_\_\_ PO # \_\_\_\_\_

PERFORMANCE BASED ON DESIGN CALCULATIONS. SUBJECT TO CHANGE WITHOUT NOTICE.

REV. 1

Main terminal diagram



3 LEAD WYE			
LINES			CONN.
L1	L2	L3	
T1	T2	T3	Y

responsible dep.  
DI MC LVM

technical reference

created by

approved by

Project

**SIEMENS**

document type  
Wiring Diagram

title  
1LE2221-1AA31-3GA3

document status  
free

document number

customer