

# Data sheet for three-phase Squirrel-Cage-Motors SIMOTICS

Motor type: **GP100** FS: **182T - 6p - 1.5 hp -**

Client order no.	Item-No.	Offer no.
Order no.	Consignment no.	Project
Remarks		

## Electrical data

U [V]	$\Delta/Y$	f [Hz]	P [HP]	P [kW]	n [rpm]	I Load [Amps]					LRC	Nom. Eff Load [%]			Pwr. Factor Load [%]			Torque [lb-ft]	T <sub>A</sub> /T <sub>N</sub> LRT [%]	T <sub>k</sub> /T <sub>N</sub> BDT [%]
						4/4	3/4	1/2	0	4/4		3/4	2/4	4/4	3/4	2/4				
460	Y	60	1.50	1.00	1,200	2.40	2.10	1.70	1.40	15.0	87.5	87.6	85.3	66.9	58.4	48.4	6.8	206	331	
230	YY	60	1.50	1.00	1,200	4.80	4.12	3.40	2.80	30.0	87.5	87.6	85.3	66.9	58.4	48.4	6.8	206	331	
400	Y	50	1.00		976	2.16	1.91	1.72	1.50	14.4	78.9	77.9	74.9	57.6	49.4	38.2	5.4	299	518	
200	YY	50	1.00		976	4.32	3.82	3.44	3.00	28.7	78.9	77.9	74.9	57.6	49.4	38.2	5.4	299	518	

Frame Type: 182T	Type of constr.: (A) Foot mounted - End shield	Ins. Cl.: Standard Class F Insulation	Motor Prot.: (A) Without Protection	NEMA Des.: B	S.F.: 1.15
Mtr. WT: 101		Temp. Rise Cl.: B	Amb. Temp.: + 40 to -20 °C @1000 m	kVA: J	IP 55

## Mechanical data

Sound level (SPL / SWL) at 60 Hz	54.0 dB(A) / 63.0 dB(A)		Thickener	Polyurea					
Octave Band Center Frequencies Hertz			Safe Stall Time Hot	34 s					
	250	500	1000	2000	4000	8000	Hz	Safe Stall Time Cold	46 s
SPL@3	36.0	46.0	52.0	47.0	41.0	31.0	dB(A)	Frame material	cast iron
Moment of inertia	0.2 Lb-ft <sup>2</sup>		Color, paint shade	Standard Paint - RAL7030					
Ext Load Inertia Capability:	23.0 Lb ft <sup>2</sup>		Coating (paint finish)	Standard Alkyed + Epoxy (C2)					
<b>Bearings</b>			<b>Ventilation Type</b>						
Bearing DE   NDE	6206 ZZ C3 S0		6206 ZZ C3 S0	Method of cooling	TEFC				
Bearing_Type	Ball Bearing		Ball Bearing	Direction of rotation	Bidirectional				
AFBMA:	30BC02JPP30		30BC02JPP30	Fan Material	Polypropylen				
<b>Grease</b>			VFD	CT: 4:1 VT: 20:1					
Capacity	0.2 oz		0.2 oz	Space heaters	without				
Grease Type:	Exxon Mobile EM		Brake:	without					

## Terminal box

Lead Wire Connection	9 LEAD - WYE				Terminal box position	(3) F-1, Standard Floor Mount, T. Box LHS
Voltage	L1	L1	L1	Connected together	Material of terminal box	Aluminium
LOW	T1 T7	T2 T8	T3 T9	T4 T5 T6	Cable entry	.75" NPT
HIGH	T1	T2	T3	T4 T7-T5 T8-T6 T9		

## Notes:

I<sub>L</sub>/I<sub>N</sub> = locked rotor current / current nominal  
M<sub>L</sub>/M<sub>N</sub> = locked rotor torque / torque nominal  
M<sub>b</sub>/M<sub>N</sub> = break down torque / nominal torque

3) Value is valid only for DOL operation with motor design IC411  
2) at rated power / at full load

responsible dep. DI MC LVM	technical reference	created by DT Configurator	approved by	<i>Technical data are subject to change! There may be discrepancies between software and hardware versions</i>	
	document type datasheet	document status released	customer		
	title 1LE2221-1CC11-4AA3	document number			
© Siemens AG 2022	rev. 01	creation date 2022-04-08 16:38	language en	Page 1/1	

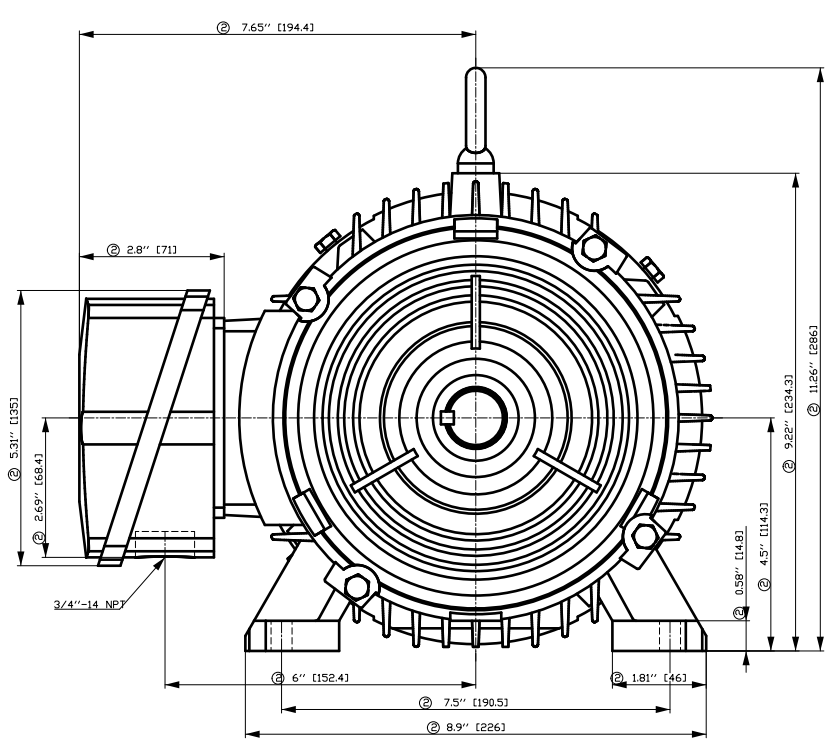

- ① Tolerances according to NEMA std.
- ② All these dimensions corresponding to assemblies and castings shall have a tolerance as per DIN standard 1686-GTB 19.
- ③ Not according to NEMA std.

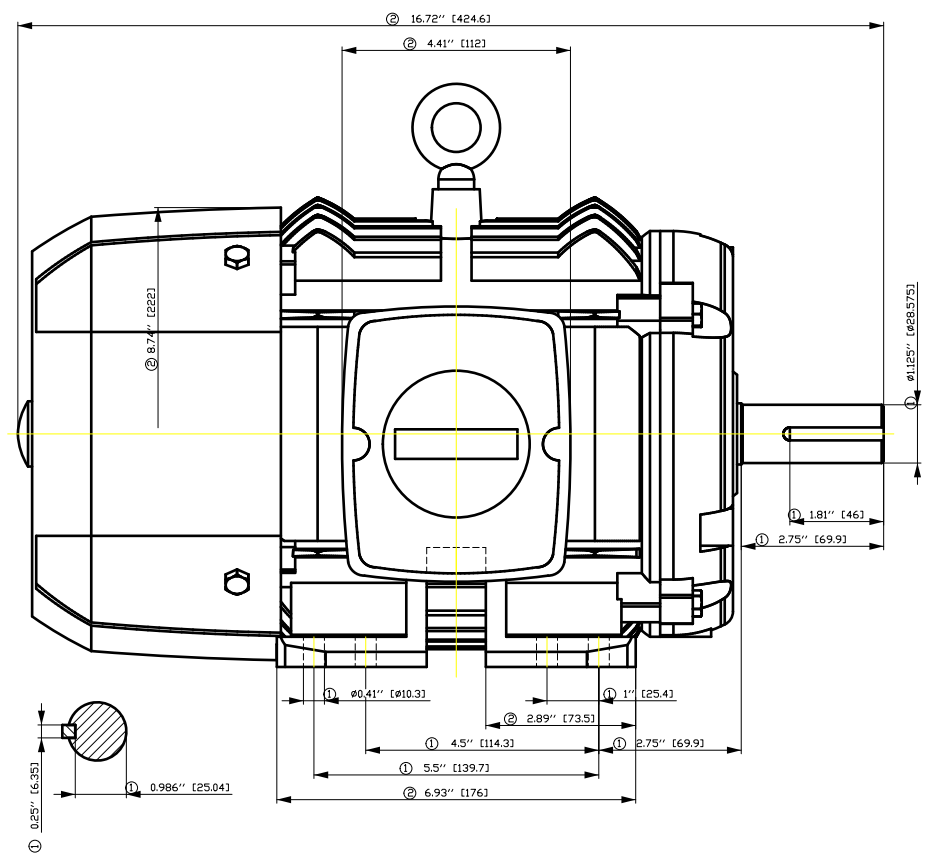

Tolerance	Surface	Material	Weight	Scale
F50GGF#-00FF# 0EH	Author	ÖS T a : ^@~ } *	E	1:1
E	Creator			
	Approval			
	Department	MLFB	Doc Type	
<b>SIEMENS</b>	Doc State	I 00G	Item No	Paper Size
	Revision	Index RS	Doc No	1st Language
	Project No	E	Ref No	2nd Language
© Siemens AG 2018				Sheet F of F

# SIEMENS INDUSTRY, INC.

HP 1,5 VOLTS < 600V RPM 1200 TYPE GP100  
HZ 60 PHASE 3 FRAME 182T NEMA B

## TORQUE & CURRENT VS. SPEED

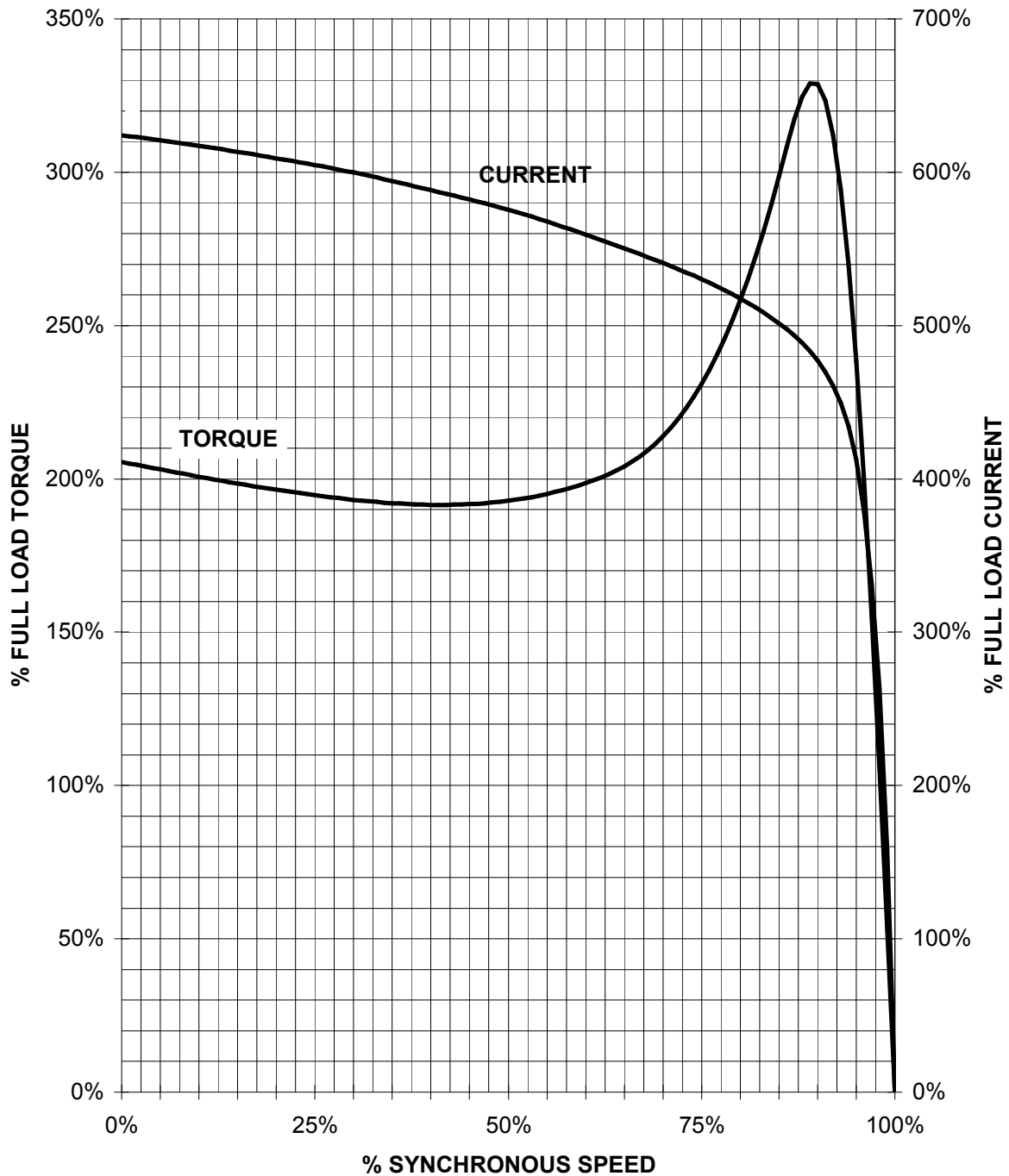

CUSTOMER: \_\_\_\_\_ ORDER#: \_\_\_\_\_

1.5 HP 1200 RPM 182T FRAME 460 VOLTS 3 PHASE NEMA DESIGN B

**SIEMENS INDUSTRY, INC.**  
**PERFORMANCE CURVE**  
**GP100**

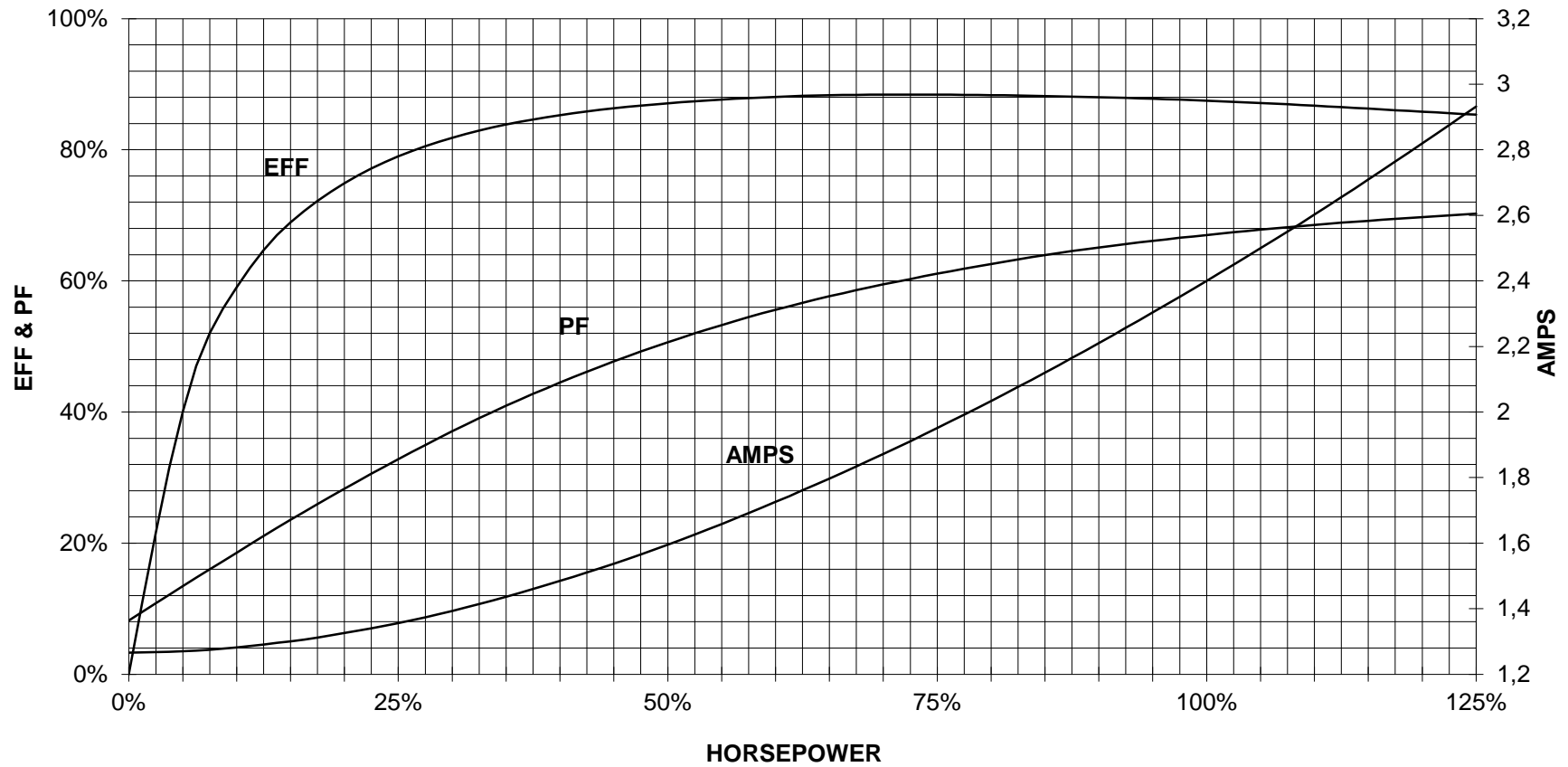

CUSTOMER \_\_\_\_\_ ORDER # \_\_\_\_\_ PO # \_\_\_\_\_

PERFORMANCE BASED ON DESIGN CALCULATIONS. SUBJECT TO CHANGE WITHOUT NOTICE.

REV. 1

Main terminal diagram

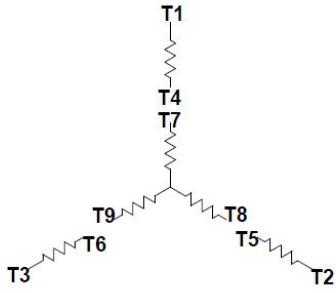

9 LEAD WYE						
Volts	LINES			CONNECTED TOGETHER	CONN.	
	L1	L2	L3			
LOW	T1 T7	T2 T6	T3 T9	T4 T5 T6	YY	
HIGH	T1	T2	T3	T4 T7-T5 T8-T6 T9	Y	

responsible dep. DI MC LVM	technical reference	created by	approved by	Project
<b>SIEMENS</b>	document type Wiring Diagram	document status free		customer
	title 1LE2221-1CC11-4AA3	document number		
© Siemens AG 2019	rev. 01	creation date 12/03/2019	language en	Page 1/1