

# Data sheet for three-phase Squirrel-Cage-Motors SIMOTICS

Motor type: **GP100** FS: **184T - 8p - 1.5 hp -**

Client order no.	Item-No.	Offer no.
Order no.	Consignment no.	Project
Remarks		

## Electrical data

U [V]	$\Delta/Y$	f [Hz]	P [HP]	P [kW]	n [rpm]	I Load [Amps]					LRC	Nom. Eff Load [%]			Pwr. Factor Load [%]			Torque [lb-ft]	T <sub>A</sub> /T <sub>N</sub> LRT [%]	T <sub>k</sub> /T <sub>N</sub> BDT [%]
						4/4	3/4	1/2	0	4/4		3/4	2/4	4/4	3/4	2/4				
575	Y	60	1.50	1.00	900	2.40	2.20	2.00	1.80	13.6	82.5	82.0	78.5	56.0	47.0	35.0	9.0	156	278	

**without**

Frame Type: 184T	Type of constr.: (A) Foot mounted - End shield	Ins. Cl.: Standard Class F Insulation	Motor Prot.: (A) Without Protection	NEMA Des.: B	S.F.: 1.15
Mtr. WT: 99		Temp. Rise Cl.: B	Amb. Temp.: + 40 to -20 °C @1000 m	kVA: L	IP 55

## Mechanical data

Sound level (SPL / SWL) at 60 Hz	54.0 dB(A) / 63.0 dB(A)		Thickener	Polyurea					
Octave Band Center Frequencies Hertz			Safe Stall Time Hot	43 s					
	250	500	1000	2000	4000	8000	Hz	Safe Stall Time Cold	63 s
SPL@3	36.0	46.0	52.0	47.0	41.0	31.0	dB(A)	Frame material	cast iron
Moment of inertia	0.3 Lb-ft <sup>2</sup>		Color, paint shade	Standard Paint - RAL7030					
Ext Load Inertia Capability:	45.0 Lb ft <sup>2</sup>		Coating (paint finish)	Standard Alkyed + Epoxy (C2)					
<b>Bearings</b>			<b>Ventilation Type</b>						
Bearing DE   NDE	6206 ZZ C3 S0		6206 ZZ C3 S0	Method of cooling	TEFC				
Bearing_Type	Ball Bearing		Ball Bearing	Direction of rotation	Bidirectional				
AFBMA:	30BC02JPP30		30BC02JPP30	Fan Material	Polypropylen				
<b>Grease</b>			VFD	CT: 4:1 VT: 20:1					
Capacity	0.2 oz		0.2 oz	Space heaters	without				
Grease Type:	Exxon Mobile EM		Brake:	without					

## Terminal box

Lead Wire Connection	3 LEAD - WYE				Terminal box position	(3) F-1, Standard Floor Mount, T. Box LHS
Voltage	L1	L1	L1	Connected together	Material of terminal box	Aluminium
----	----	----	----	----	Cable entry	.75" NPT
----	T1	T2	T3	----		

## Notes:

I<sub>L</sub>/I<sub>N</sub> = locked rotor current / current nominal  
M<sub>L</sub>/M<sub>N</sub> = locked rotor torque / torque nominal  
M<sub>B</sub>/M<sub>N</sub> = break down torque / nominal torque

3) Value is valid only for DOL operation with motor design IC411  
2) at rated power / at full load

responsible dep. DI MC LVM	technical reference	created by DT Configurator	approved by	<i>Technical data are subject to change! There may be discrepancies between software and hardware versions</i>	
	document type datasheet	document status released	customer		
	title 1LE2221-1CD31-3AA3	document number			
© Siemens AG 2022	rev. 01	creation date 2022-04-08 16:46	language en	Page 1/1	

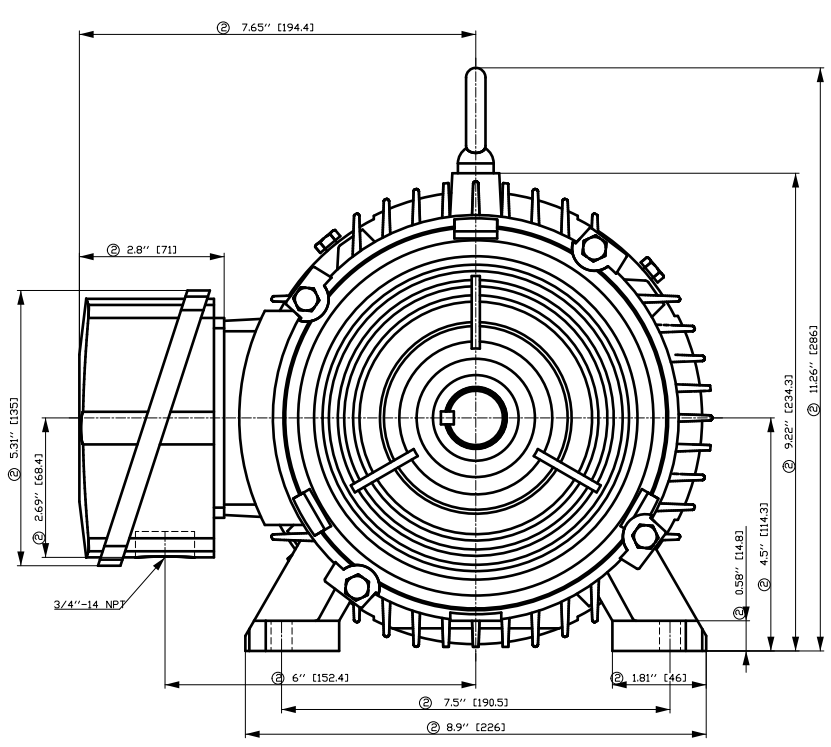

- ① Tolerances according to NEMA std.
- ② All these dimensions corresponding to assemblies and castings shall have a tolerance as per DIN standard 1686-GTB 19.
- ③ Not according to NEMA std.

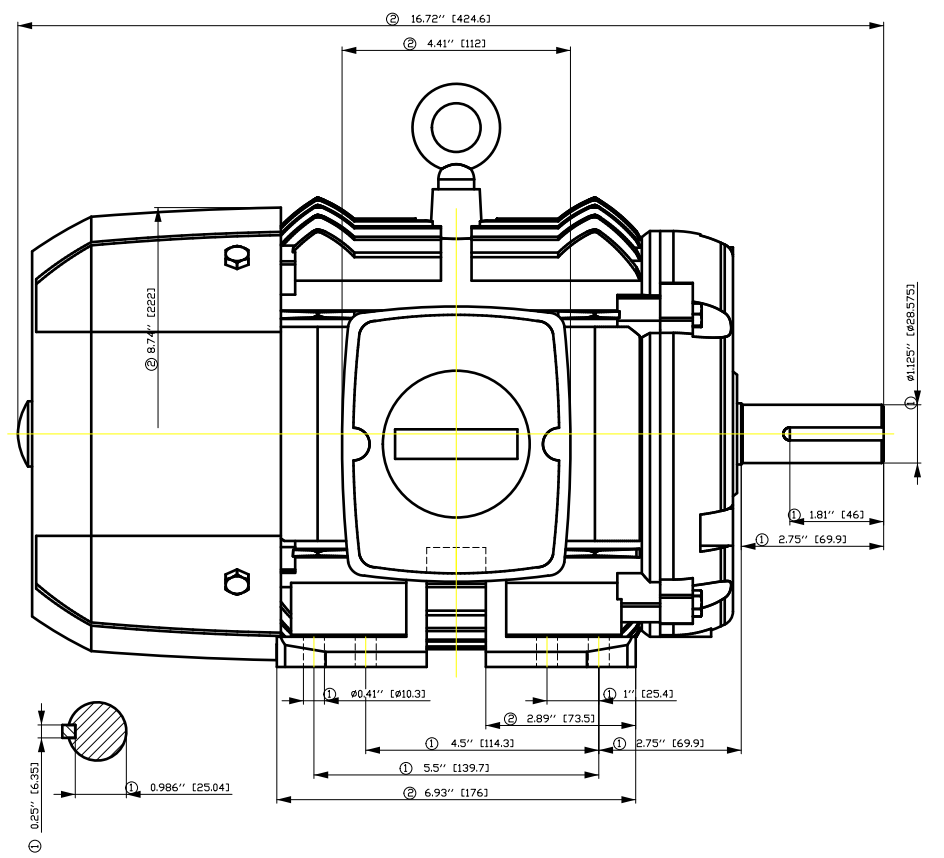

Tolerance	Surface	Material	Weight	Scale
F50GGF#00FH0EH E	Author Creator Approval Department Change Order	ÖS T a : ^ & @ } *	E	{ {
<b>SIEMENS</b>	Doc. State Revision	Item No Doc No	Doc Type	Paper Size
© Siemens AG 2018	Index RS	1st Language 2nd Language		
	Project No	Ref No	Sheet	F of F

刀痕等  
 用文字  
 标注  
 在图  
 中  
 表示  
 出  
 来  
 的  
 形  
 状  
 和  
 尺  
 寸  
 等  
 信  
 息  
 均  
 以  
 图  
 中  
 的  
 注  
 释  
 为  
 准  
 凡  
 有  
 修  
 改  
 或  
 更  
 改  
 均  
 以  
 图  
 中  
 的  
 注  
 释  
 为  
 准  
 凡  
 有  
 修  
 改  
 或  
 更  
 改  
 均  
 以  
 图  
 中  
 的  
 注  
 释  
 为  
 准

# SIEMENS INDUSTRY, INC.

HP 1,5 VOLTS < 600V RPM 900 TYPE GP100  
HZ 60 PHASE 3 FRAME 184T NEMA B

## TORQUE & CURRENT VS. SPEED

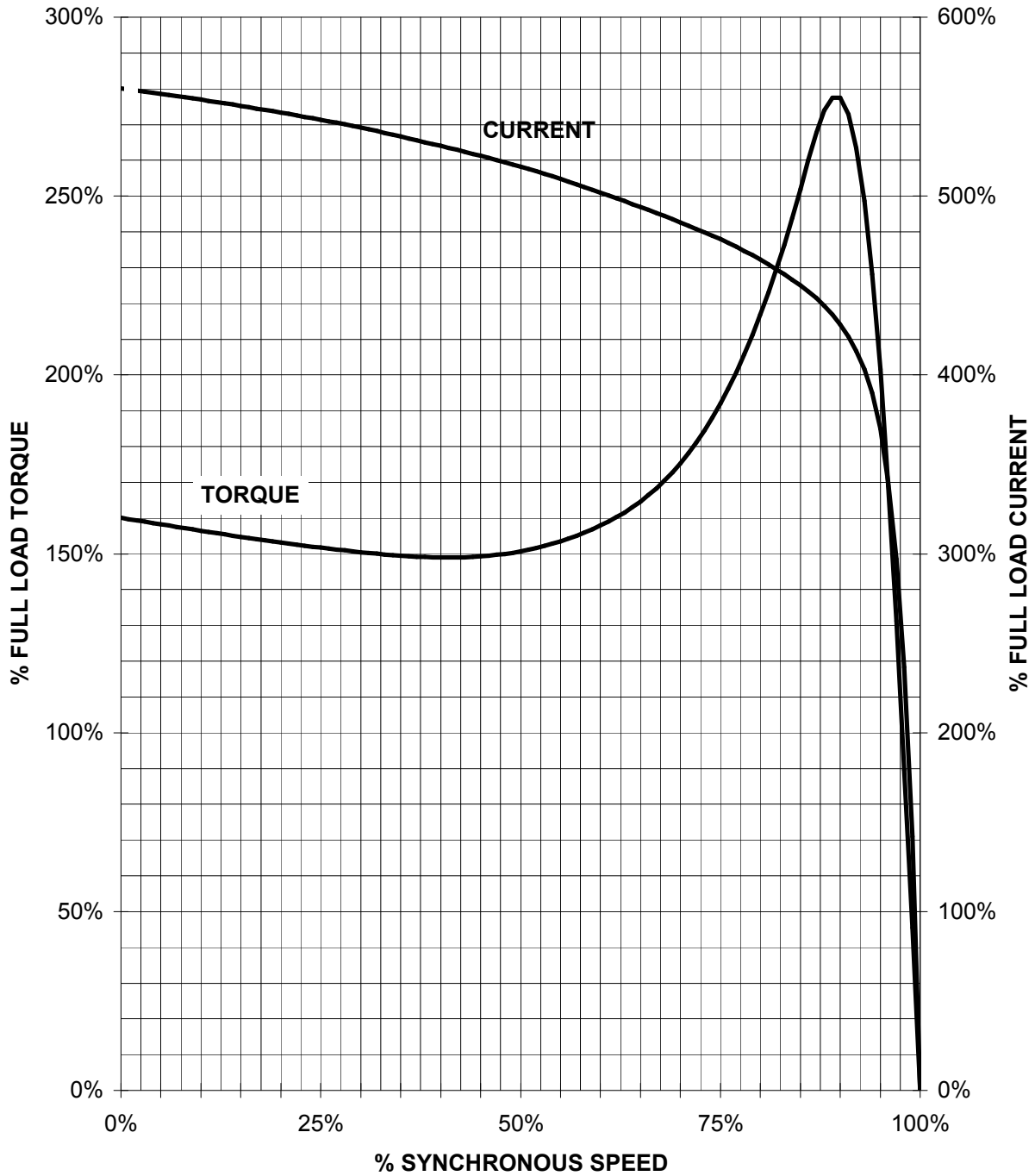

CUSTOMER: \_\_\_\_\_ ORDER#: \_\_\_\_\_

1.5 HP 900 RPM 184T FRAME 575 VOLTS 3 PHASE NEMA DESIGN B

**SIEMENS INDUSTRY, INC.  
PERFORMANCE CURVE  
GP100**

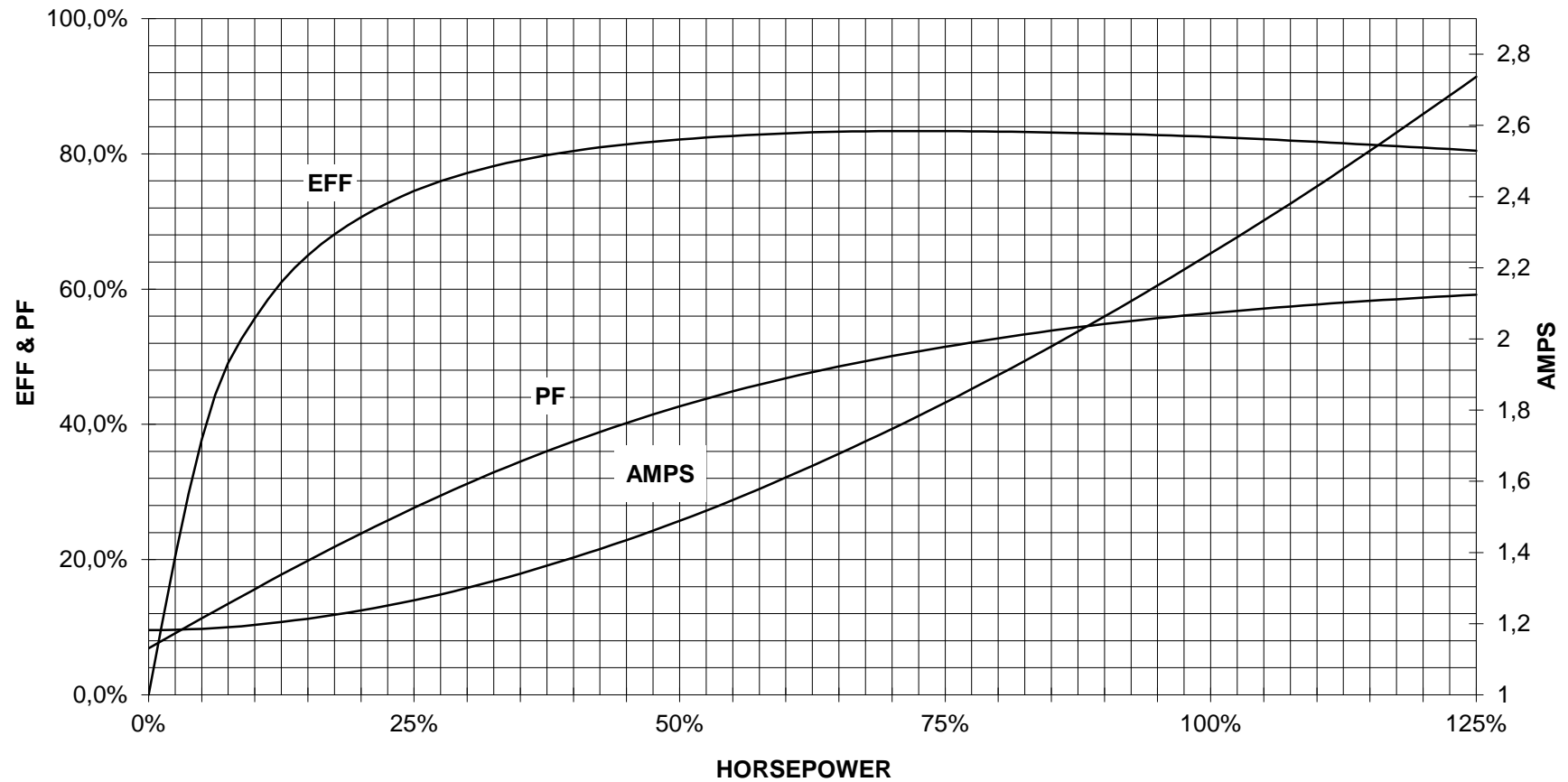

CUSTOMER \_\_\_\_\_ ORDER # \_\_\_\_\_ PO # \_\_\_\_\_

PERFORMANCE BASED ON DESIGN CALCULATIONS. SUBJECT TO CHANGE WITHOUT NOTICE.

REV. 1

Main terminal diagram



3 LEAD WYE			
LINES			CONN.
L1	L2	L3	
T1	T2	T3	Y

responsible dep.  
DI MC LVM

technical reference

created by

approved by

Project

**SIEMENS**

document type  
Wiring Diagram

title  
1LE2221-1CD31-3AA3

document status  
free

document number

customer