



## NEMA Motor Data

MLFB-Ordering data : 1LE2221-2AA11-4GA3

Client order no. :  
Order no. :  
Offer no. :  
Remarks :

Item no. :  
Consignment no. :  
Project :

Nameplate Data	Mounting and motor protection
----------------	-------------------------------

Type: GP100 - NEMA Premium Efficiency			
HP	7.5	Rating	Cont.
Voltage	(14) 230/460V, 60Hz (Suitable for 208V)	Ins. Class	Class F (Standard)
Amps	17.6 / 8.8 A	S.F.	1.15
FL RPM	3520	Amb. Temp.	+40C TO -20C
FL Efficiency	89.5 %	Temp. Rise	Class B
FRAME	213TC	kVA Code	H
DE AFBMA	40BC02JPP30	NEMA Des	B
ODE AFBMA	40BC02JPP30	Mtr WT	209
60 Hertz	3 Ph TEFC	IP	55

Type of construction	( G ) Round body - C-Face
Motor protection	(A) Without Protection
Terminal box design	(3) F-1, Standard Floor Mount, T. Box

Bearing Data		
	DE	ODE
Bearing Size	6208 ZZ C3 S0	6208 ZZ C3 S0
Bearing Type	Ball Bearing	Ball Bearing
AFBMA	40BC02JPP30	40BC02JPP30

Typical Performance Data					
--------------------------	--	--	--	--	--

Load	No Load	1/2	3/4	Full Load	LRC
Efficiency		89.6 %	90.1 %	89.5 %	
Power Factor		78.5	86.8	89.2	
Current (A)	3.0 A	5.0 A	6.7 A	17.6 / 8.8 A	63.0 A
Inverter Duty	VT	20:1	CT	4:1	

Mechanical Data				
-----------------	--	--	--	--

SAFE STALL TIME	HOT (s)	17	COLD (s)	30
Rtr wt (lbs)	29.49	Rtr WK2	0.42	
FLT (lb-ft)	11.0	LRT (%)	182	BDT (%) 500
Ext Load Inertia (WK2) Capability	8.3 lb-ft <sup>2</sup>			
Brake:	without			

Typical Noise Data										
--------------------	--	--	--	--	--	--	--	--	--	--

A-weighted Sound	Octave Band Center Frequencies Hertz (Hz)								
Pressure Level	125	250	500	1000	2000	4000	8000	SPL	66
at 3 feet	36	53	55	63	62	58	47	SPwrL	78

Wiring Connection Information					
-------------------------------	--	--	--	--	--

Description	3 PHASE - 9 LEAD - WYE				
Voltage	L1	L2	L3	Connected together	
LOW	T1 T7	T2 T8	T3 T9	T4 T5 T6 YY	
HIGH	T1	T2	T3	T4 T7-T5 T8-T6 T9 Y	

Special design :
------------------

Lubrication Information	
-------------------------	--

Manufacturer	Mobil Polyrex EM or equal
Type	Polyurea (standard)
DE Capacity (oz.)	0.30
ODEnd Capacity (oz.)	0.30

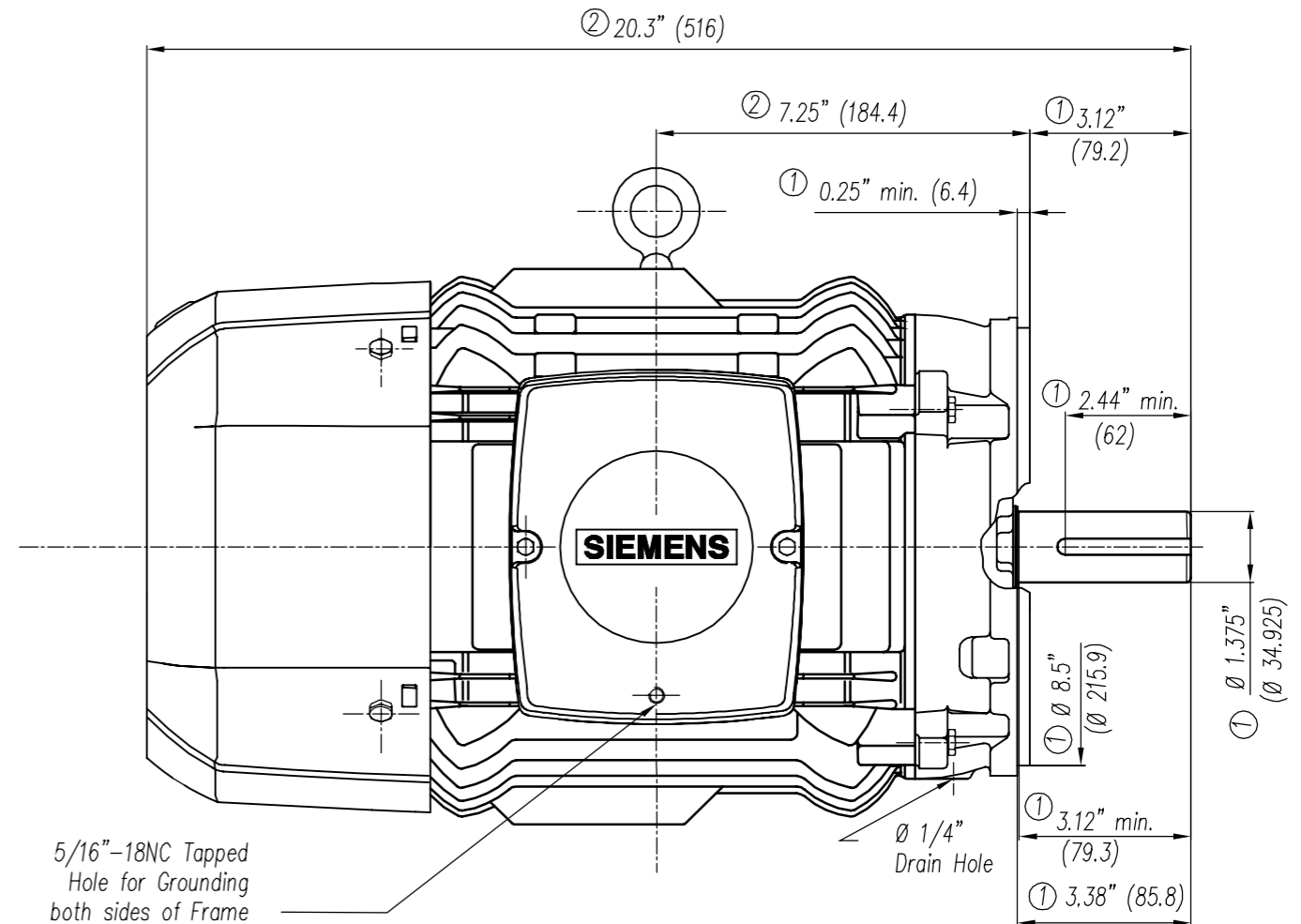
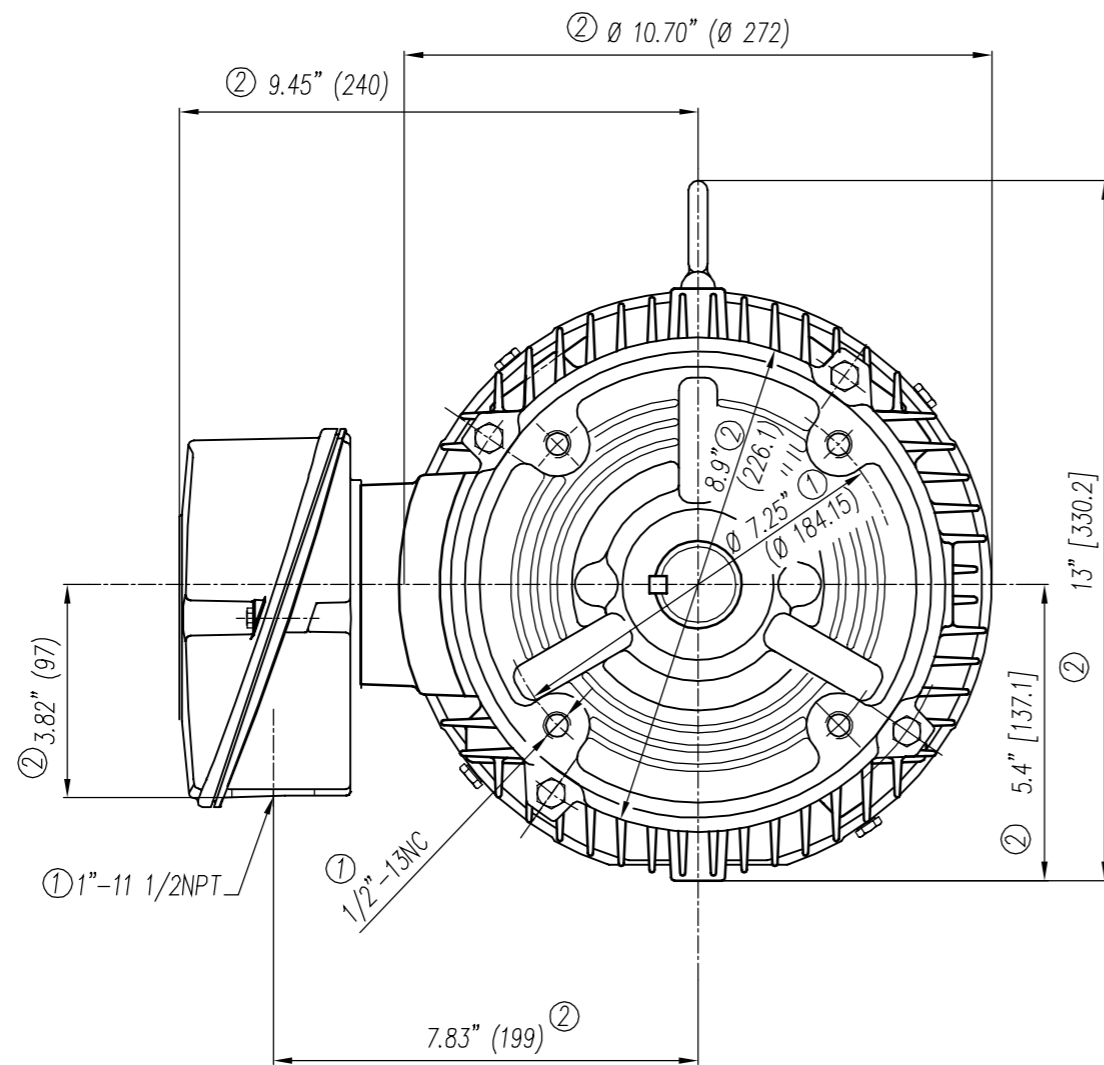

5/16"-18NC Tapped Hole for Grounding both sides of Frame

- |   |  |
|---|--|
| ① Tolerances According to NEMA Std.   | ① Tolerancias acorde a NEMA Std.   |
| ② All these dimensions corresponding to assemblies and castings shall have a tolerance as per DIN standard 1686-GTB 19. | ② Todas estas dimensiones correspondientes a ensambles y fundición en bruto tendrán una tolerancia según DIN 1686-GTB-19 |
| ③ Not According to NEMA Std.  | ③ No Acorde a NEMA Std.  |

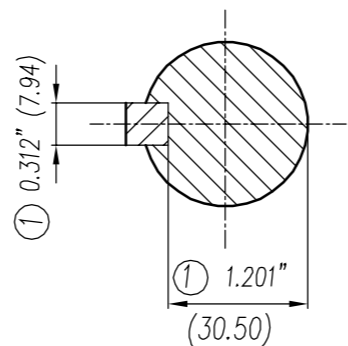

Keyseat detail  
Detalle Cuñero

CERTIFIED PRINT/CERTIFICACION							
CUSTOMER/CLIENTE							
PO#/ORDEN COMPRA#				SD#/ORDEN CLIENTE#			
HP	RPM	FRAME/ARM.	TYPE/TIPO	VOLTS	PH/FAS.	HZ	

Tol. in mm. acc. to/Tol. en mm. según DIN-1686-GTB-19		European Projection/ Proyeccion Europea	Modific.	a) Se cambió formato a Inglés-Español y se especificó tipos en los que aplica este dibujo.	
Over/desde	to/hasta			a) Changed the format to English-Spanish and was especificed in what kind of motors apply this drawing.	
---	18	± 4.5			
18	30	± 4.7			
30	50	± 5			
50	80	± 5.5			
80	120	± 6			
120	180	± 6.5			
180	250	± 7			
250	315	± 7.5			
315	400	± 8			
400	500	± 8.5			
500	630	± 9.5			
630	800	± 10			
			Date/Fecha	Name/Nombre	Outline/Dimensiones New NEMA Motors
			13/04/2016	R. KAISER	
			Drawn/Elab.		Type/ Tipo: GP100 215TCV Frame
			Check/Rev.		
			Std.Ckd./Aut		3MSE 232 0601
			<b>SIEMENS</b> GUADALAJARA FACTORY		Ref. 3MSE2220853A)01 3MSE222085201
			Rep./Sdo.		-/-

### 3 PHASE - 9 LEADS - WYE

VOLTS	LINES			CONNECTED TOGETHER	CONN.
	L1	L2	L3		
LOW	T1 T7	T2 T8	T3 T9	T4 T5 T6	Y Y
HIGH	T1	T2	T3	T4 T7-T5 T8-T6 T9	Y

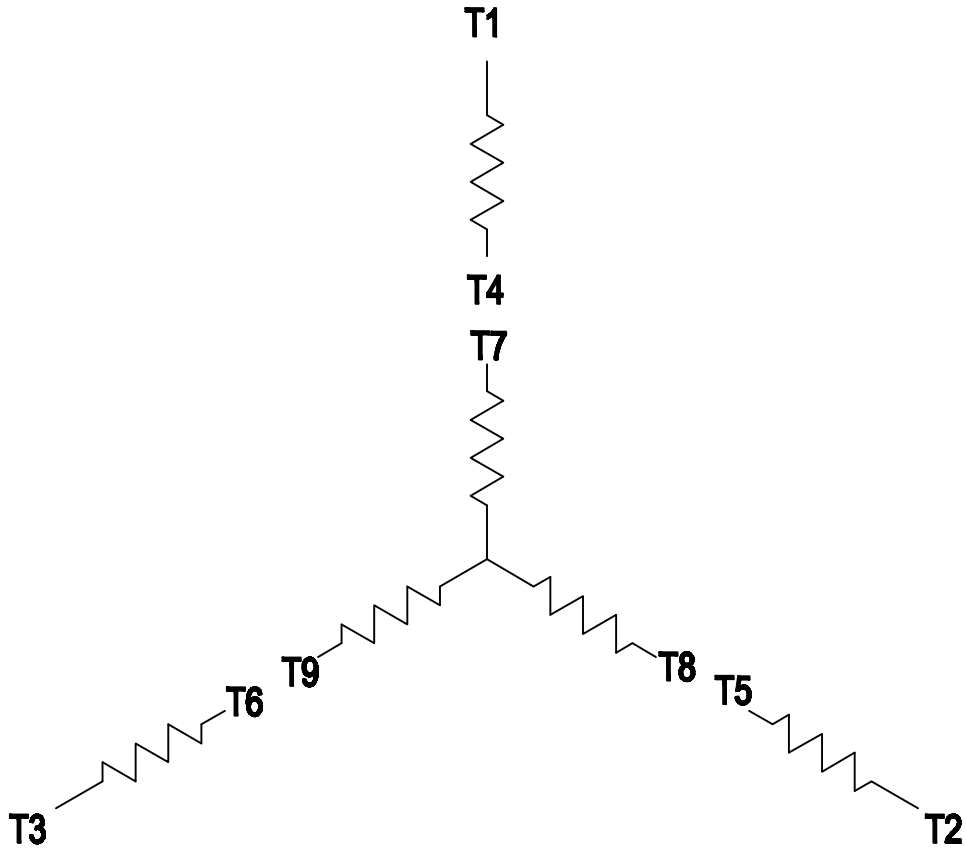

THIS IS A CAD DRAWING  
DO NOT MAKE MANUAL CHANGES

01 | 09-27-07

TYPE

-CONFIDENTIAL-

PROPERTY OF

Siemens Energy & Automation, Inc.  
Industrial Motor Division - Little Rock, AR

FRAME

HP

NAME

WIRING DIAGRAM

VOLTS

RPM

HZ

PH

3

Customer

PO #

SO #

DRAWN 9.24.07

DATE JRH

CHECKED

DATE

APP

DATE

SHEET

1 OF 1

Sim. To

PART NO.

51-382-114-501

A

# SIEMENS INDUSTRY, INC.

HP 7,5 VOLTS < 600V RPM 3600 TYPE GP100  
HZ 60 PHASE 3 FRAME 213T NEMA B

## TORQUE & CURRENT VS. SPEED

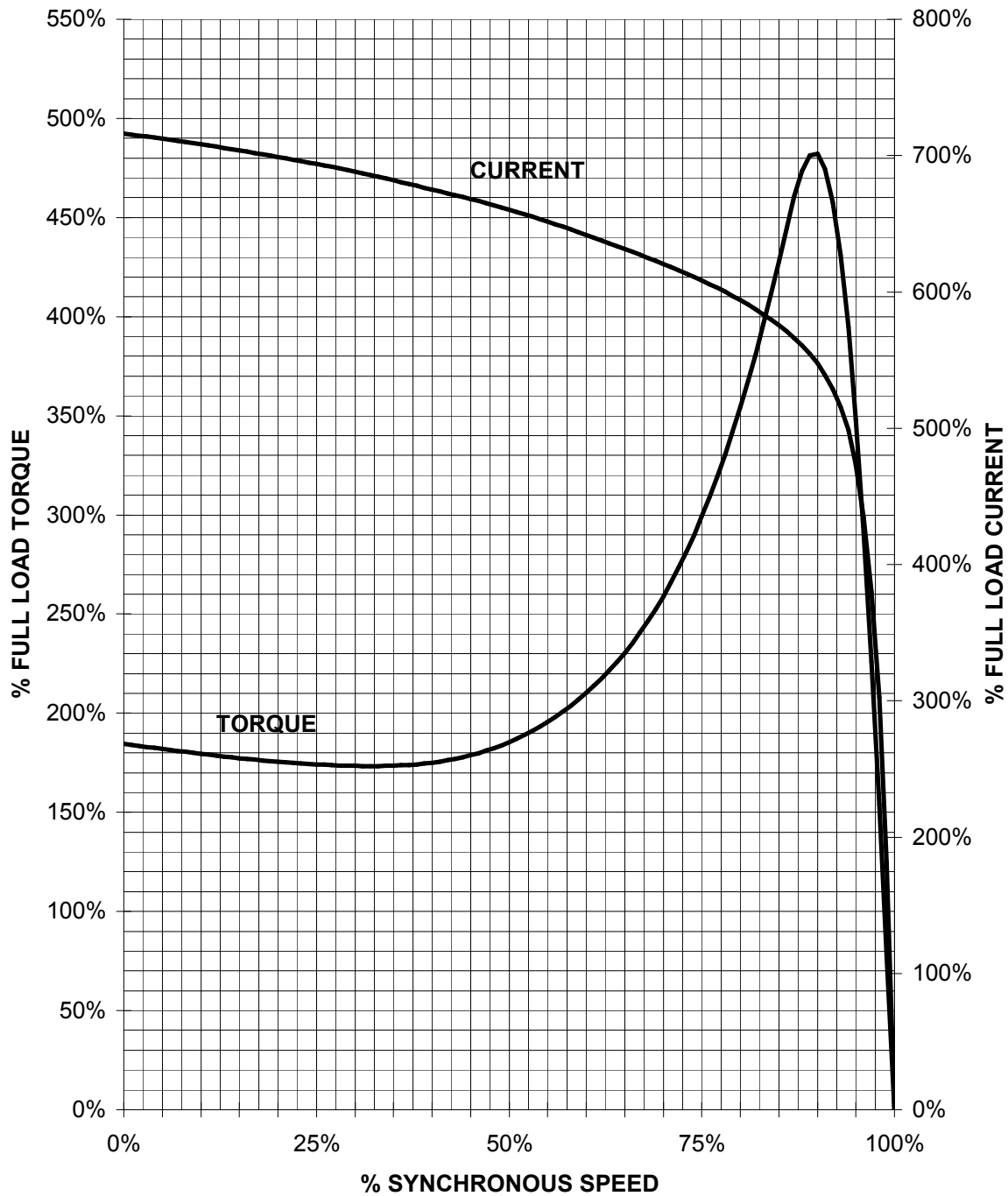

CUSTOMER: \_\_\_\_\_ ORDER#: \_\_\_\_\_

7.5 HP 3600 RPM 213T FRAME 460 VOLTS 3 PHASE NEMA DESIGN B

**SIEMENS INDUSTRY, INC.**  
**PERFORMANCE CURVE**  
**GP100**

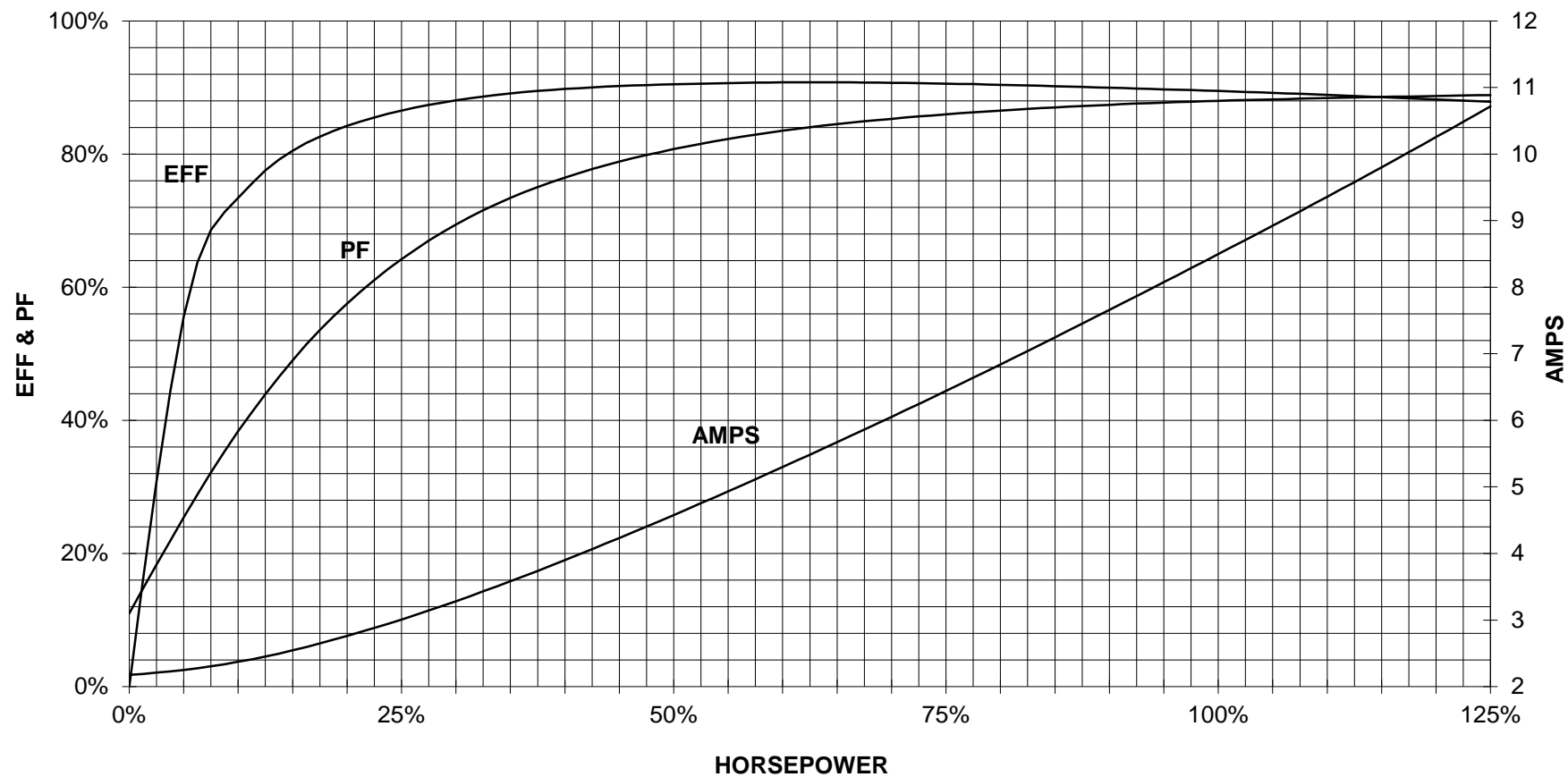

CUSTOMER \_\_\_\_\_ ORDER # \_\_\_\_\_ PO # \_\_\_\_\_

PERFORMANCE BASED ON DESIGN CALCULATIONS. SUBJECT TO CHANGE WITHOUT NOTICE.

REV. 1