



NEMA Motor Data

MLFB-Ordering data : 1LE2221-2AC21-4AA3

Client order no. :
Order no. :
Offer no. :
Remarks :

Item no. :
Consignment no. :
Project :

Nameplate Data	Mounting and motor protection
----------------	-------------------------------

Type: GP100 - NEMA Premium Efficiency

HP	5.0	Rating	Cont.
Voltage	(14) 230/460V, 60Hz (Suitable for 208V)	Ins. Class	Class F (Standard)
Amps	13.4 / 6.7 A	S.F.	1.15
FL RPM	1165	Amb. Temp.	+40C TO -20C
FL Efficiency	89.5 %	Temp. Rise	Class B
FRAME	215T	kVA Code	J
DE AFBMA	40BC02JPP30	NEMA Des	B
ODE AFBMA	40BC02JPP30	Mtr WT	171
60 Hertz	3 Ph TEFC	IP	55

Type of construction	(A) Foot mounted - End shield
Motor protection	(A) Without Protection
Terminal box design	(3) F-1, Standard Floor Mount, T. Box

Bearing Data		
	DE	ODE
Bearing Size	6208 ZZ C3 S0	6208 ZZ C3 S0
Bearing Type	Ball Bearing	Ball Bearing
AFBMA	40BC02JPP30	40BC02JPP30

Typical Performance Data					
--------------------------	--	--	--	--	--

Load	No Load	1/2	3/4	Full Load	LRC
Efficiency		89.5 %	90.1 %	89.5 %	
Power Factor		59.4	71.4	78.1	
Current (A)	3.5 A	4.4 A	5.5 A	13.4 / 6.7 A	46.0 A
Inverter Duty	VT	20:1	CT	4:1	

Mechanical Data				
-----------------	--	--	--	--

SAFE STALL TIME	HOT (s)	14	COLD (s)	21
Rtr wt (lbs)	38.22	Rtr WK2	0.71	
FLT (lb-ft)	26.5	LRT (%)	189	BDT (%) 325
Ext Load Inertia (WK2) Capability	71.0 lb-ft ²			
Brake:	without			

Typical Noise Data									
--------------------	--	--	--	--	--	--	--	--	--

A-weighted Sound	Octave Band Center Frequencies Hertz (Hz)								
Pressure Level	125	250	500	1000	2000	4000	8000	SPL	64
at 3 feet	41	42	52	64	54	47	34	SPwrL	71

Wiring Connection Information					
-------------------------------	--	--	--	--	--

Description 3 PHASE - 9 LEAD - WYE

Voltage	L1	L2	L3	Connected together	
LOW	T1 T7	T2 T8	T3 T9	T4 T5 T6 YY	
HIGH	T1	T2	T3	T4 T7-T5 T8-T6 T9 Y	

Special design :

Lubrication Information	
-------------------------	--

Manufacturer	Mobil Polyrex EM or equal
Type	Polyurea (standard)
DE Capacity (oz.)	0.30
ODEnd Capacity (oz.)	0.30

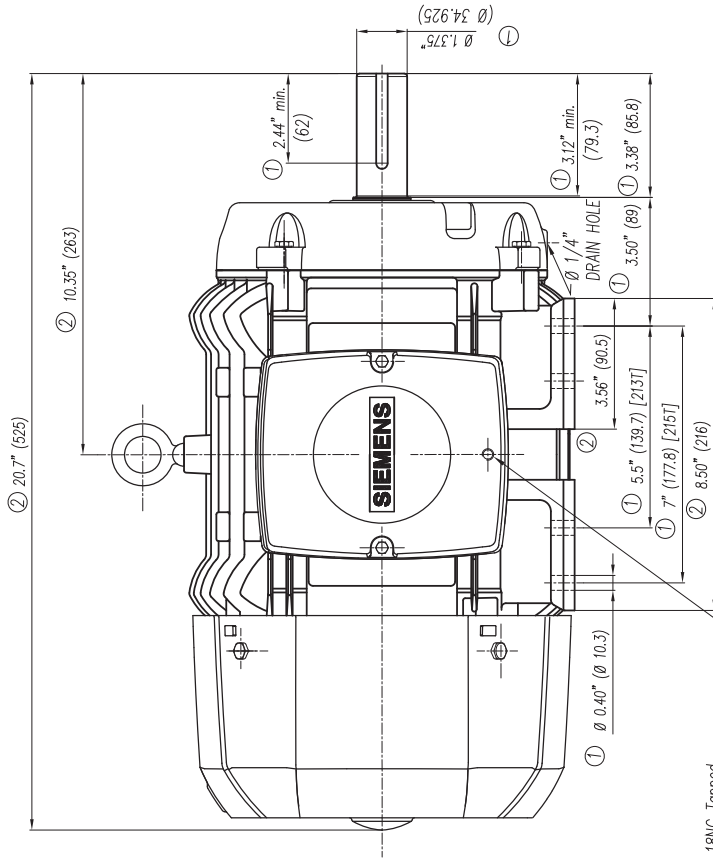
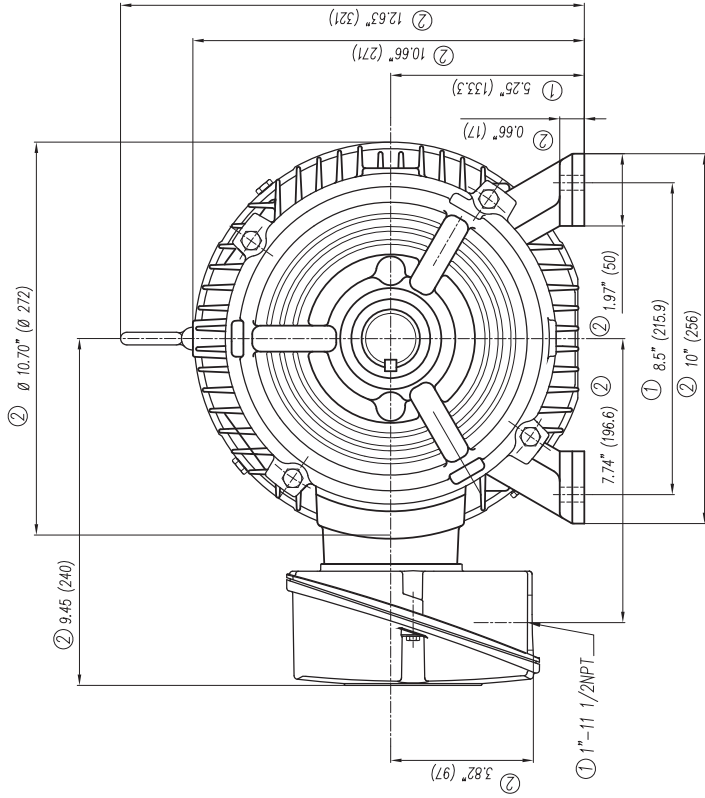

5/16" -18NC Tapped Hole for Grounding both sides of Frame

- ① Tolerances According to NEMA Std.
- ② All these dimensions corresponding to assemblies and castings shall have a tolerance as per DIN standard 1686-GTB 19.
- ③ Not According to NEMA Std.

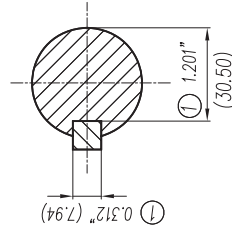

Keyseat detail
Detalle Cuiño

CERTIFIED PRINT/CERTIFICACION			
CUSTOMER/CLIENTE			
PROYECTOR/COMPRA		SUNBORN/CLIENTE	
IP	REV	FRANK/ORA	TYPE/TPP
		VALS	PHAFAS
			RE

Tol. in mm. acc. to/Tot. en mm. según DIN-1686-GTB-19 Over/desde To/Hasta		18 ± 4.5 30 ± 4.7 50 ± 5 80 ± 5.5 120 ± 6 180 ± 6.5 250 ± 7 315 ± 7.5 400 ± 8 500 ± 8.5 630 ± 9.5 800 ± 10
European Projection/ Proyección Europea		Date/Fecha 03/03/08
Dim. in inches/Dim. en pulg.		Name/Nombre Guymán
Scale/ Escala Sin W/O		Type/ Tipo: GP100 213/215T Arm.
(1) Se cambió formato a Inglés-Español y se especificó tipos en los que aplica este dibujo. (2) Changed the format to English-Spanish and was specified in what kind of motors apply this drawing.		Outline/Dimensiones New NEMA Motors
SIEMENS GUADALAJARA FACTORY		3MSE 222 0850a)
Ref.		Rep./ 3MSE 222 0850 Sd6

3 PHASE - 9 LEADS - WYE

VOLTS	LINES			CONNECTED TOGETHER	CONN.
	L1	L2	L3		
LOW	T1 T7	T2 T8	T3 T9	T4 T5 T6	Y Y
HIGH	T1	T2	T3	T4 T7-T5 T8-T6 T9	Y

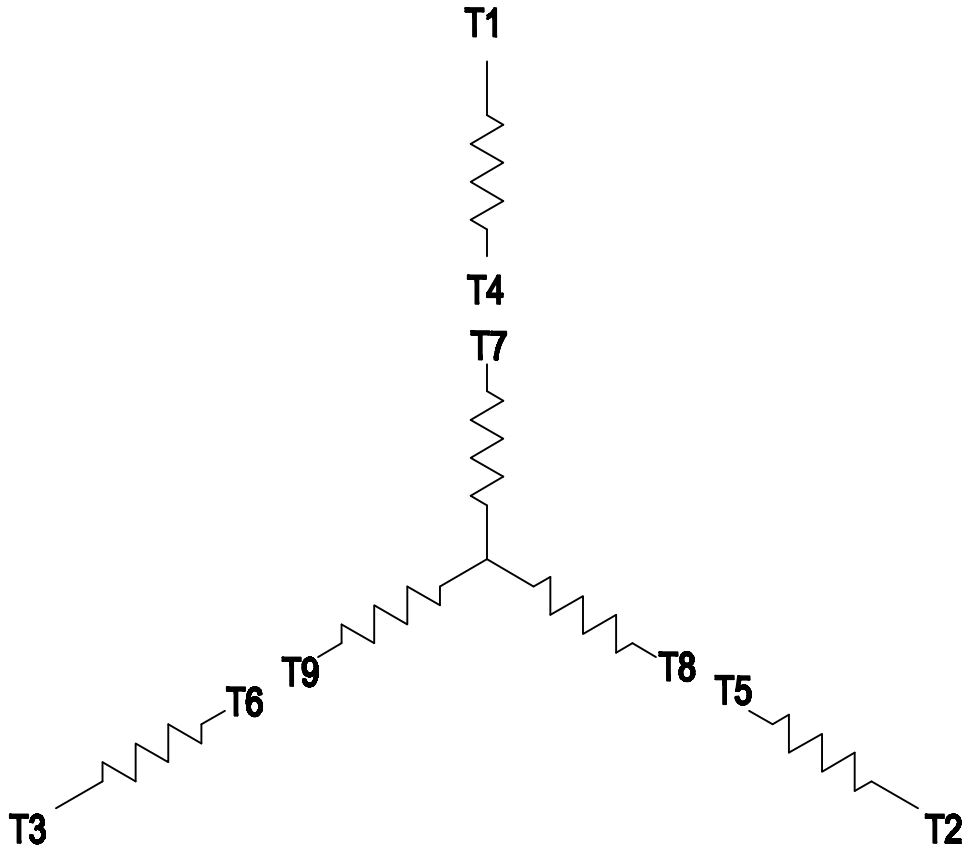

THIS IS A CAD DRAWING
DO NOT MAKE MANUAL CHANGES

01 | 09-27-07

TYPE

-CONFIDENTIAL-

PROPERTY OF

Siemens Energy & Automation, Inc.
Industrial Motor Division - Little Rock, AR

FRAME

HP

NAME

WIRING DIAGRAM

VOLTS

RPM

HZ

PH

3

Customer

PO #

SO #

DRAWN 9.24.07

DATE

JRH

CHECKED

DATE

APP

DATE

SHEET

1 OF 1

Sim. To

PART NO.

51-382-114-501

A

SIEMENS INDUSTRY, INC.

HP 5 VOLTS < 600V RPM 1200 TYPE GP100
HZ 60 PHASE 3 FRAME 215T NEMA B

TORQUE & CURRENT VS. SPEED

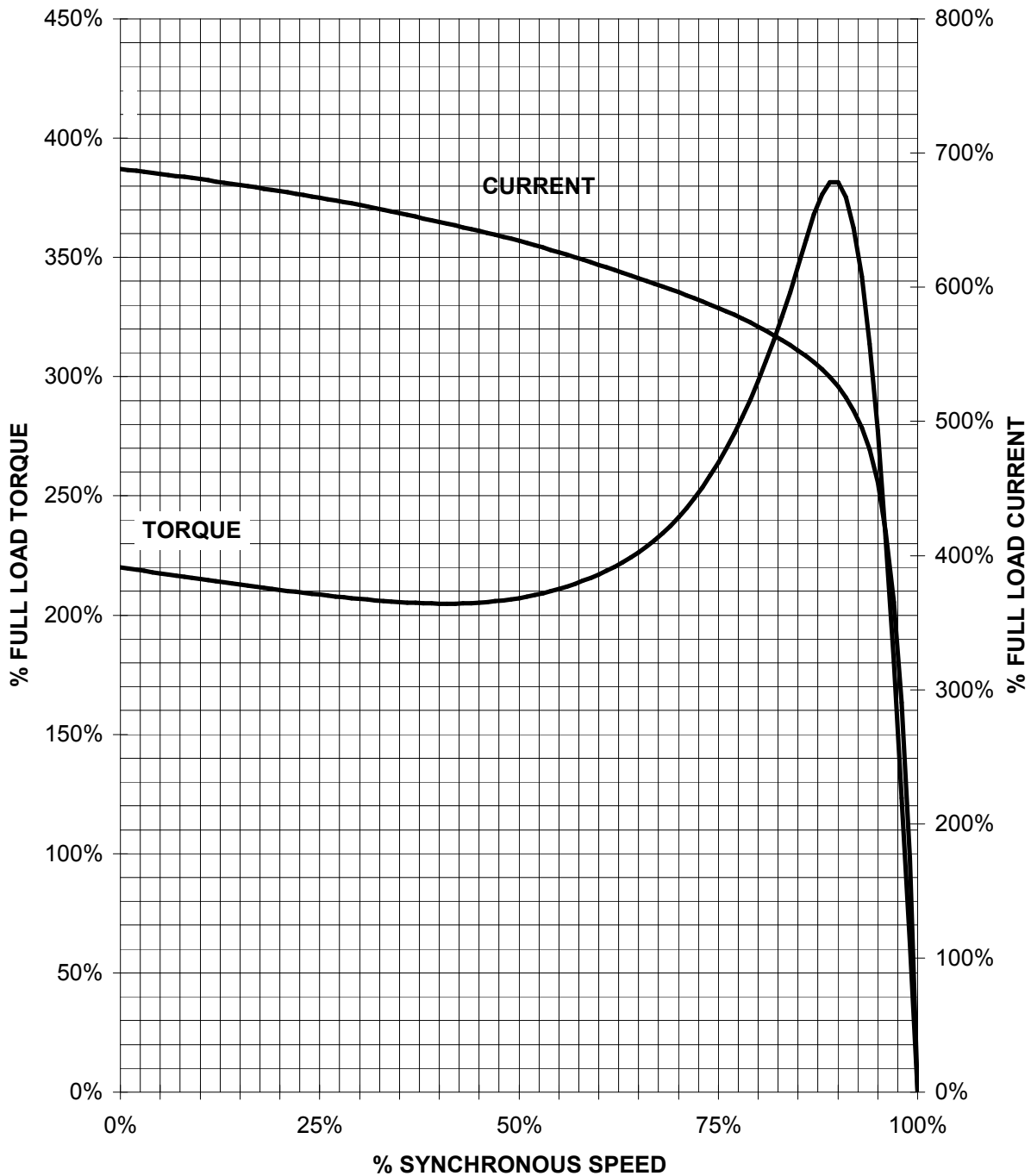

CUSTOMER: _____ ORDER#: _____

5 HP 1200 RPM 215T FRAME 460 VOLTS 3 PHASE NEMA DESIGN B

SIEMENS INDUSTRY, INC.
PERFORMANCE CURVE
GP100

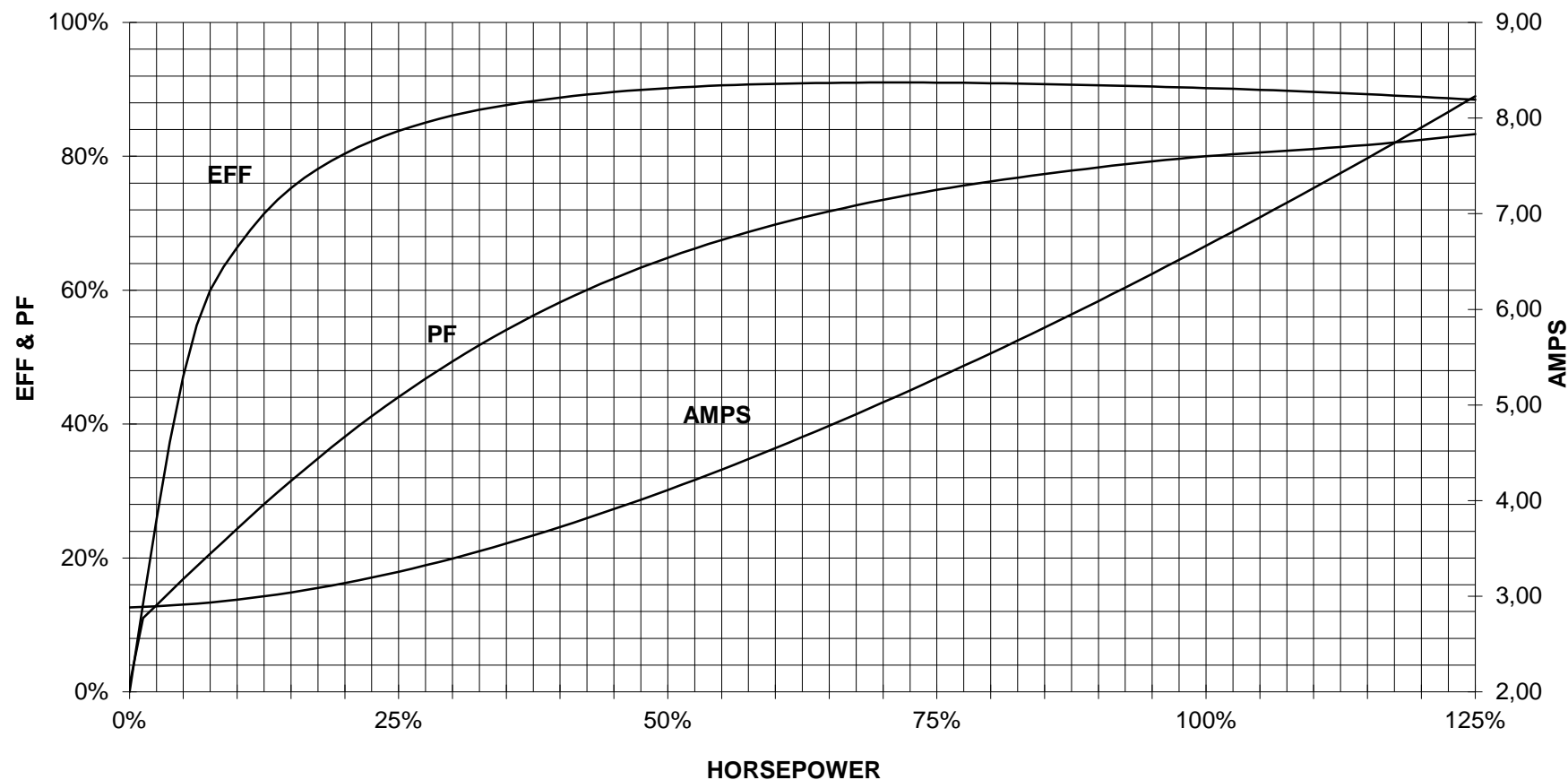

CUSTOMER _____ ORDER # _____ PO # _____

PERFORMANCE BASED ON DESIGN CALCULATIONS. SUBJECT TO CHANGE WITHOUT NOTICE.

REV. 1