

Data sheet for three-phase Squirrel-Cage-Motors SIMOTICS

Motor type: **GP100** FS: **256T - 2p - 20 hp -**

Client order no.	Item-No.	Offer no.
Order no.	Consignment no.	Project
Remarks		

Electrical data

U [V]	Δ/Y	f [Hz]	P [HP]	P [kW]	n [rpm]	I Load [Amps]					LRC	Nom. Eff Load [%]			Pwr. Factor Load [%]			Torque [lb-ft]	T _A /T _N LRT [%]	T _k /T _N BDT [%]
						4/4	3/4	1/2	0	4/4		3/4	2/4	4/4	3/4	2/4				
575	Y	60	20.00	15.00	3,600	18.00	13.40	9.40	4.20	116.0	91.0	91.6	92.1	91.5	91.3	86.2	30.0	183	230	

Frame Type: 256T	Type of constr.: (A) Foot mounted - End shield	Ins. Cl.: Standard Class F Insulation	Motor Prot.: (A) Without Protection	NEMA Des.: B	S.F.: 1.15
Mtr. WT: 313		Temp. Rise Cl.: B	Amb. Temp.: + 40 to -20 °C @1000 m	kVA: G	IP 55

Mechanical data

Sound level (SPL / SWL) at 60 Hz	67.0 dB(A) / 79.0 dB(A)							Thickener	Polyurea
Octave Band Center Frequencies Hertz								Safe Stall Time Hot	20 s
	250	500	1000	2000	4000	8000	Hz	Safe Stall Time Cold	45 s
SPL@3	54.0	56.0	63.0	62.0	60.0	48.0	dB(A)	Frame material	cast iron
Moment of inertia	1.4 Lb-ft ²							Color, paint shade	Standard Paint - RAL7030
Ext Load Inertia Capability:	21.0 Lb ft ²							Coating (paint finish)	Standard Alkyed + Epoxy (C2)
Bearings								Ventilation Type	
Bearing DE NDE	6209 ZZ C3 S0			6209 ZZ C3 S0				Method of cooling	TEFC
Bearing_Type	Ball Bearing			Ball Bearing				Direction of rotation	Bidirectional
AFBMA:	45BC02JPP30			45BC02JPP30				Fan Material	Polypropylen
Grease								VFD	CT: 4:1 VT: 20:1
Capacity	0.5 oz			0.5 oz				Space heaters	without
Grease Type:	Exxon Mobile EM							Brake:	without

Terminal box

Lead Wire Connection					3 LEAD - WYE					Terminal box position	(3) F-1, Standard Floor Mount, T. Box LHS				
Voltage	L1	L1	L1	Connected together						Material of terminal box	Aluminium				
----	----	----	----	----						Cable entry	1.25" NPT				
----	T1	T2	T3	----											

Notes:

I_L/I_N = locked rotor current / current nominal
M_L/M_N = locked rotor torque / torque nominal
M_B/M_N = break down torque / nominal torque

3) Value is valid only for DOL operation with motor design IC411
2) at rated power I at full load

responsible dep. DI MC LVM	technical reference	created by DT Configurator	approved by	<i>Technical data are subject to change! There may be discrepancies between datasheet and customer's order</i>			
	document type datasheet	document status released		customer			
	title 1LE2221-2BA21-3AA3	document number					
© Siemens AG 2022	rev. 01	creation date 2022-04-08 19:05	language en	Page 1/1			

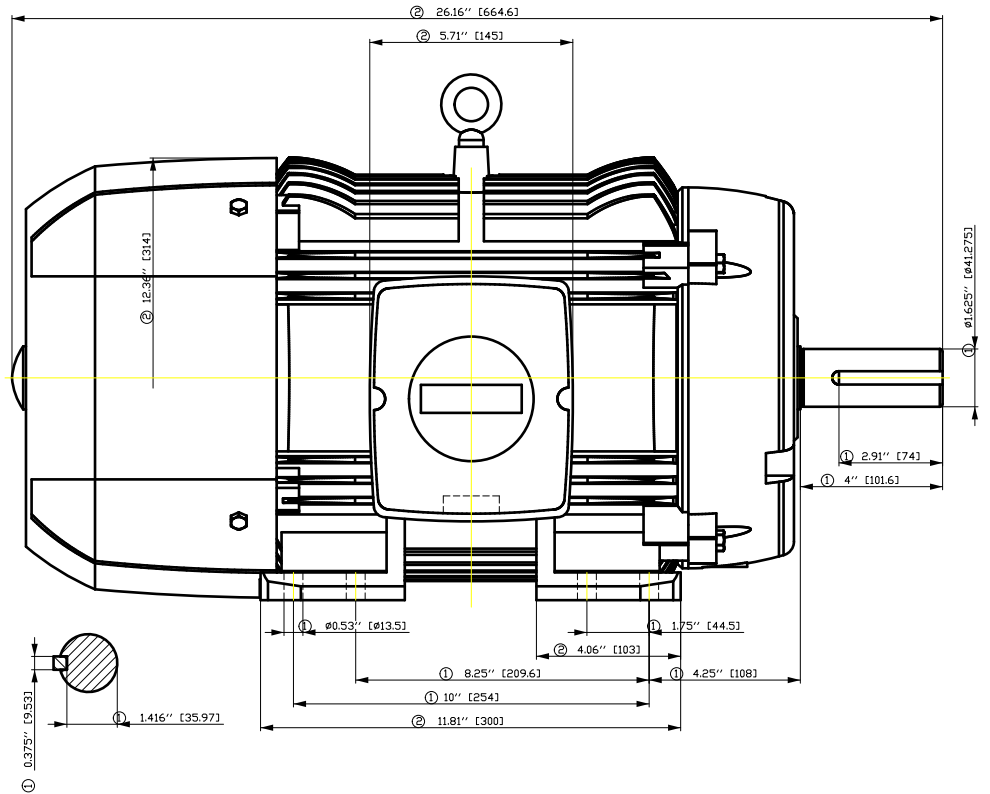
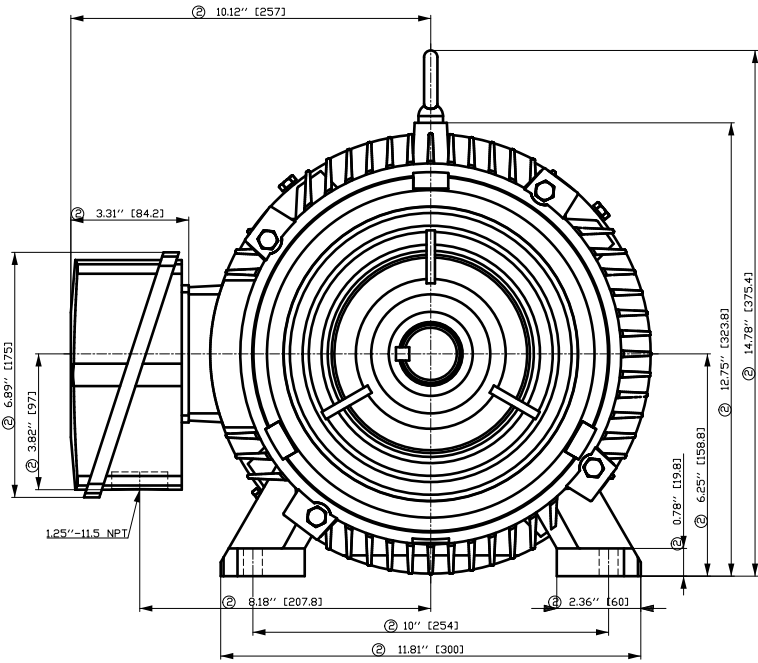

- ① Tolerances according to NEMA std.
- ② All these dimensions corresponding to assemblies and castings shall have a tolerance as per DIN standard 1686-GTB 19.
- ③ Not according to NEMA std.

Tolerance	Surface	Material	Weight	Scale	
F50GGF-E00GF-H00H	Author	ÖS Tæ: ^æ@` }*	E		
E	Creator				ÖVS
	Approval				
	Department				
	Change Order	MLFB	Doc Type	/	
	Doc State	I 00GG	Item No	Paper Size	
	Revision	Index	RS	1st Language	
				2nd Language	
© Siemens AG	2018	Project No	E	Ref No	
			E	Sheet	
				F of F	

SIEMENS INDUSTRY, INC.

HP 20 VOLTS < 600V RPM 3600 TYPE GP100
HZ 60 PHASE 3 FRAME 256T NEMA B

TORQUE & CURRENT VS. SPEED

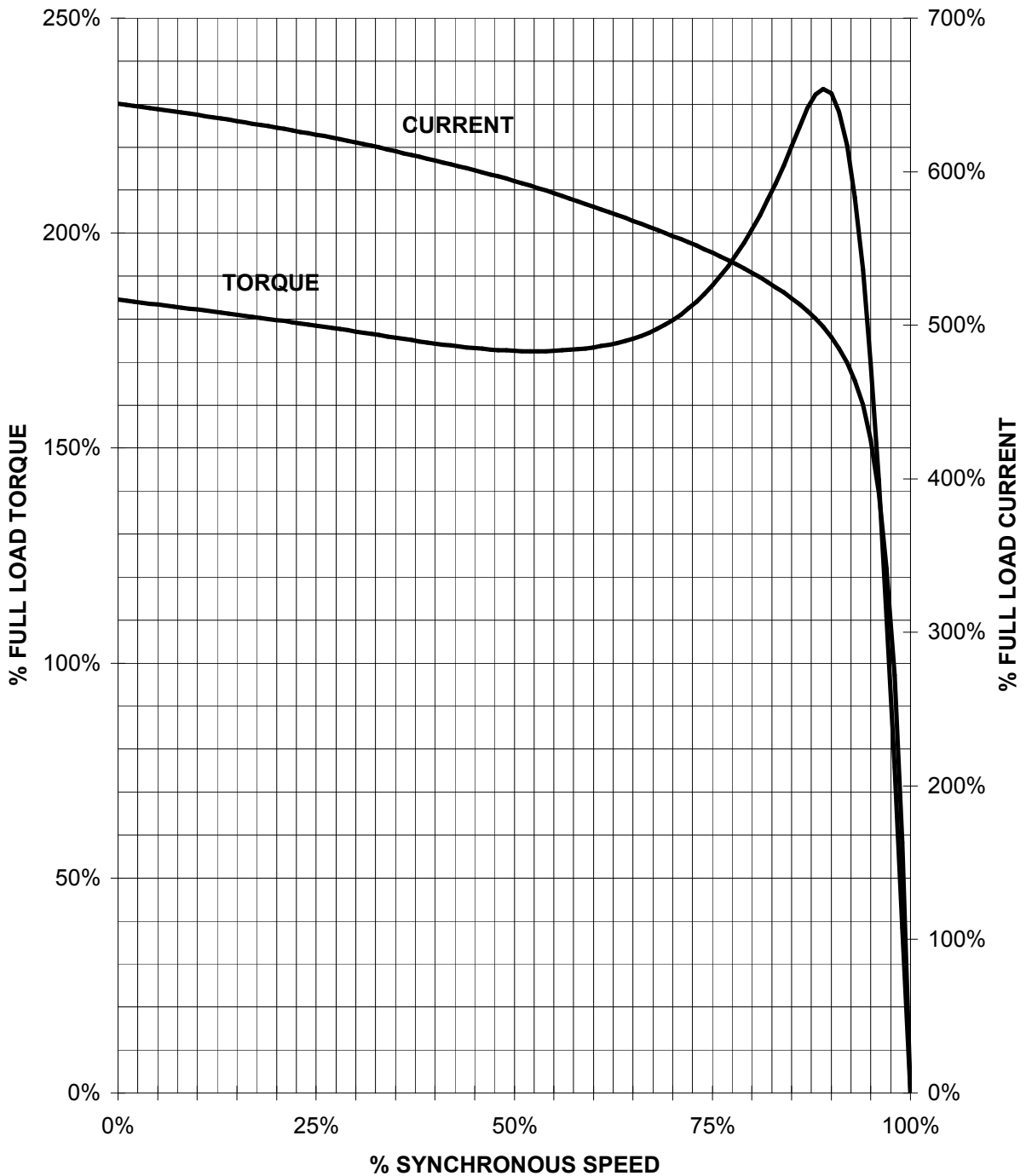

CUSTOMER: _____ ORDER#: _____

20 HP 3600 RPM 256T FRAME 575 VOLTS 3 PHASE NEMA DESIGN B

SIEMENS INDUSTRY, INC.
PERFORMANCE CURVE
GP100

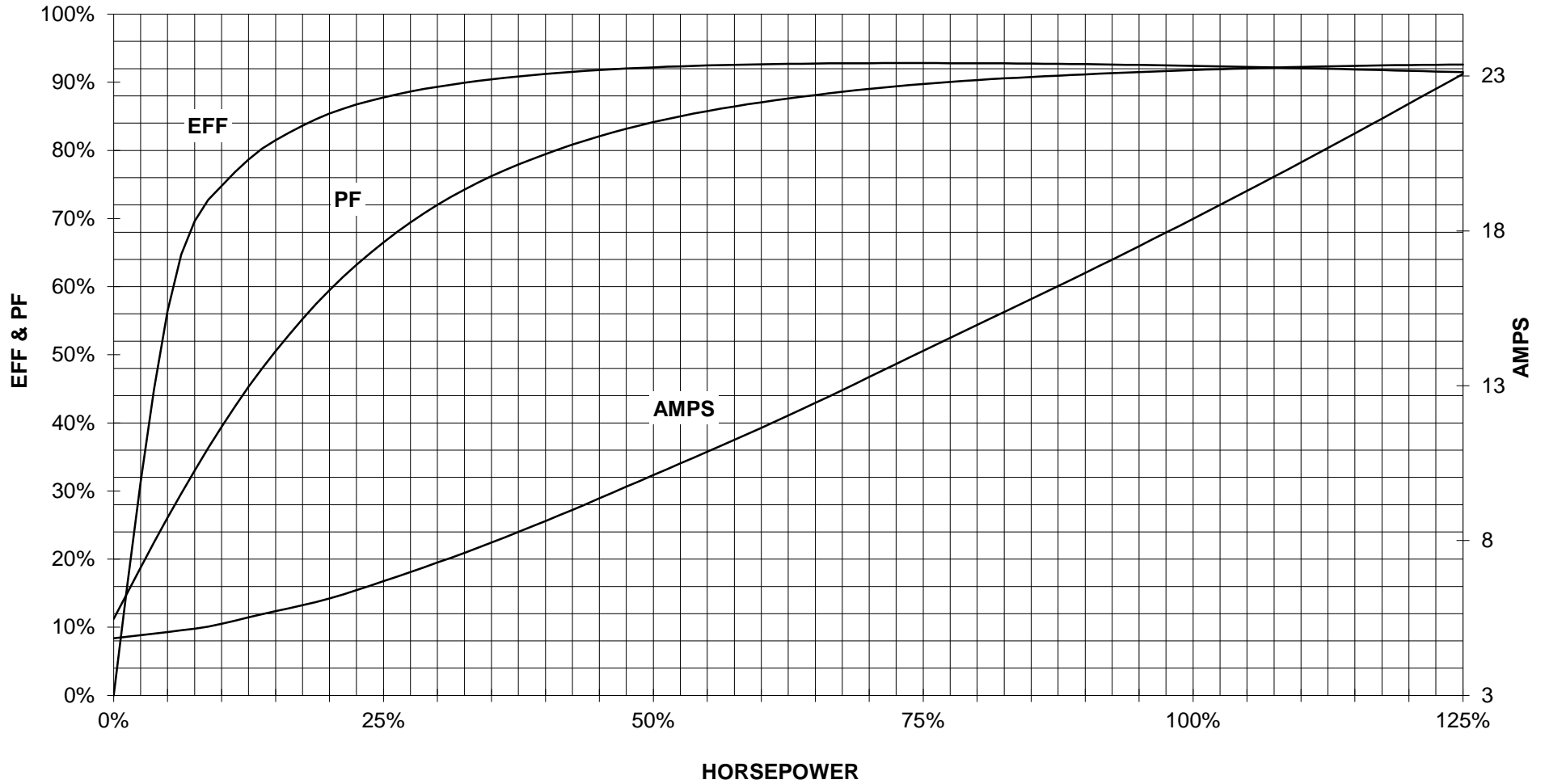

CUSTOMER _____ ORDER # _____ PO # _____

PERFORMANCE BASED ON DESIGN CALCULATIONS. SUBJECT TO CHANGE WITHOUT NOTICE.

REV. 1

Main terminal diagram



3 LEAD WYE			
LINES			CONN.
L1	L2	L3	
T1	T2	T3	Y

responsible dep.
DI MC LVM

technical reference

created by

approved by

Project

SIEMENS

document type
Wiring Diagram

title
1LE2221-2BA21-3AA3

document status
free

document number

customer