

Data sheet for three-phase Squirrel-Cage-Motors SIMOTICS

Motor type: **GP100** FS: 256T - 2p - 20 hp -

Client order no.	Item-No.	Offer no.
Order no.	Consignment no.	Project
Remarks		

Electrical data

U [V]	Δ/Y	f [Hz]	P [HP]	P [kW]	n [rpm]	I Load [Amps]					LRC	Nom. Eff Load [%]			Pwr. Factor Load [%]			Torque [lb-ft]	T _A /T _N LRT [%]	T _k /T _N BDT [%]
						4/4	3/4	1/2	0	4/4		3/4	2/4	4/4	3/4	2/4				
460	Y	60	20.00	15.00	3,600	22.50	16.80	11.80	5.20	145.0	91.0	91.6	92.1	91.5	91.3	86.2	30.0	183	230	
230	YY	60	20.00	15.00	3,600	45.00	33.59	23.59	10.40	290.0	91.0	91.6	92.1	91.5	91.3	86.2	30.0	183	230	
400	Y	50	15.00		2,935	18.90	14.40	10.30	5.00	133.3	91.2	91.9	91.7	92.1	90.0	84.2	26.9	225	330	
200	YY	50	15.00		2,935	37.80	28.80	20.60	10.00	266.6	91.2	91.9	91.7	92.1	90.0	84.2	26.9	225	330	

without

Frame Type: 256T	Type of constr.: (E) Foot mounted - C-Face	Ins. Cl.: Standard Class F Insulation	Motor Prot.: (A) Without Protection	NEMA Des.: B	S.F.: 1.15
Mtr. WT: 313		Temp. Rise Cl.: B	Amb. Temp.: + 40 to -20 °C @1000 m	kVA: G	IP 55

Mechanical data

Sound level (SPL / SWL) at 60 Hz	67.0 dB(A) / 79.0 dB(A)							Thickener	Polyurea
Octave Band Center Frequencies Hertz								Safe Stall Time Hot	20 s
	250	500	1000	2000	4000	8000	Hz	Safe Stall Time Cold	45 s
SPL@3	54.0	56.0	63.0	62.0	60.0	48.0	dB(A)	Frame material	cast iron
Moment of inertia	1.4 Lb-ft ²							Color, paint shade	Standard Paint - RAL7030
Ext Load Inertia Capability:	21.0 Lb ft ²							Coating (paint finish)	Standard Alkyed + Epoxy (C2)
Bearings								Ventilation Type	
Bearing DE NDE	6209 ZZ C3 S0			6209 ZZ C3 S0				Method of cooling	TEFC
Bearing_Type	Ball Bearing			Ball Bearing				Direction of rotation	Bidirectional
AFBMA:	45BC02JPP30			45BC02JPP30				Fan Material	Polypropylen
Grease								VFD	CT: 4:1 VT: 20:1
Capacity	0.5 oz			0.5 oz				Space heaters	without
Grease Type:	Exxon Mobile EM							Brake:	without

Terminal box

Lead Wire Connection	9 LEAD - WYE				Terminal box position	(3) F-1, Standard Floor Mount, T. Box LHS
Voltage	L1	L1	L1	Connected together	Material of terminal box	Aluminium
LOW	T1 T7	T2 T8	T3 T9	T4 T5 T6	Cable entry	1.25" NPT
HIGH	T1	T2	T3	T4 T7-T5 T8-T6 T9		

Notes:

I_L/I_N = locked rotor current / current nominal
M_L/M_N = locked rotor torque / torque nominal
M_B/M_N = break down torque / nominal torque
3) Value is valid only for DOL operation with motor design IC411
2) at rated power / at full load

responsible dep. DI MC LVM	technical reference	created by DT Configurator	approved by	<i>Technical data are subject to change! There may be discrepancies between software and hardware versions</i>			
	document type datasheet	document status released		customer			
	title 1LE2221-2BA21-4EA3	document number					
© Siemens AG 2022	rev. 01	creation date 2022-04-08 19:06	language en	Page 1/1			

01) 02) 03) 04) 05) 06) 07) 08) 09) 10) 11) 12) 13) 14) 15) 16) 17) 18) 19) 20) 21) 22) 23) 24) 25) 26) 27) 28) 29) 30) 31) 32) 33) 34) 35) 36) 37) 38) 39) 40) 41) 42) 43) 44) 45) 46) 47) 48) 49) 50) 51) 52) 53) 54) 55) 56) 57) 58) 59) 60) 61) 62) 63) 64) 65) 66) 67) 68) 69) 70) 71) 72) 73) 74) 75) 76) 77) 78) 79) 80) 81) 82) 83) 84) 85) 86) 87) 88) 89) 90) 91) 92) 93) 94) 95) 96) 97) 98) 99) 100)

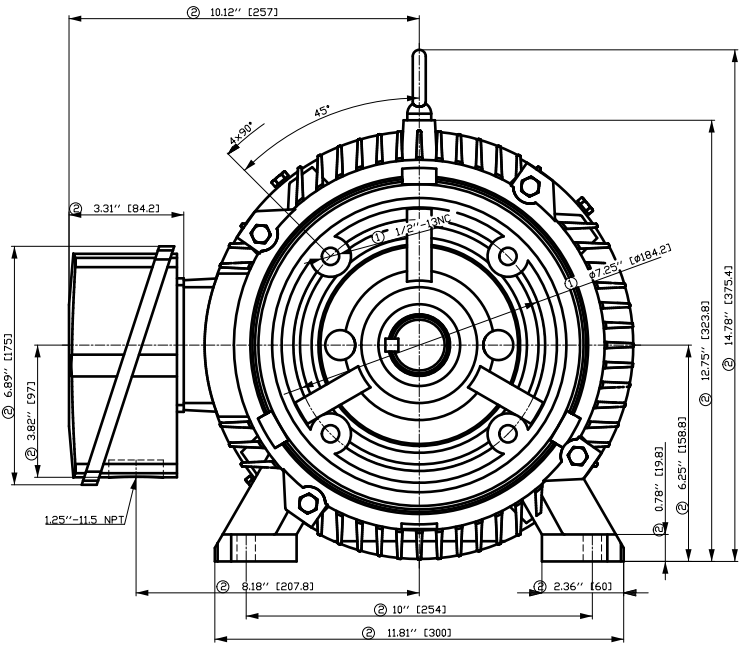

- ① Tolerances according to NEMA std.
- ② All these dimensions corresponding to assemblies and castings shall have a tolerance as per DIN standard 1686-GTB 19.
- ③ Not according to NEMA std.

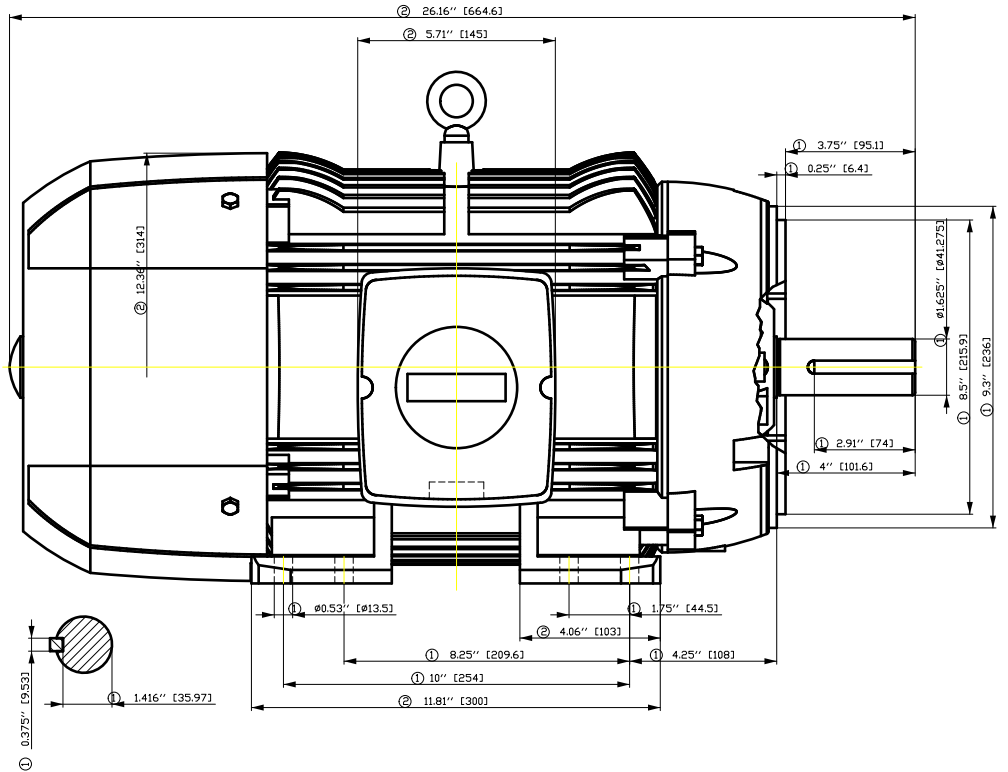

| Tolerance | Surface | Material | Weight | Scale |
|-----------------------------------|--------------|----------|--------------|------------------|
| F S O C G F E B O C G F E B O C H | Author | Ö S | E | |
| E | Creator | | | |
| | Approval | | | |
| | Department | | | |
| | Change Order | MFB | Doc Type | |
| SIEMENS | Doc State | I B B G | Item No | Paper Size C H |
| | Revision | Index RS | Doc No | 1st Language ^ |
| | | | | 2nd Language a ^ |
| © Siemens AG 2018 | Project No E | Ref No E | Sheet F of F | |

SIEMENS INDUSTRY, INC.

HP 20 VOLTS < 600V RPM 3600 TYPE GP100
HZ 60 PHASE 3 FRAME 256T NEMA B

TORQUE & CURRENT VS. SPEED

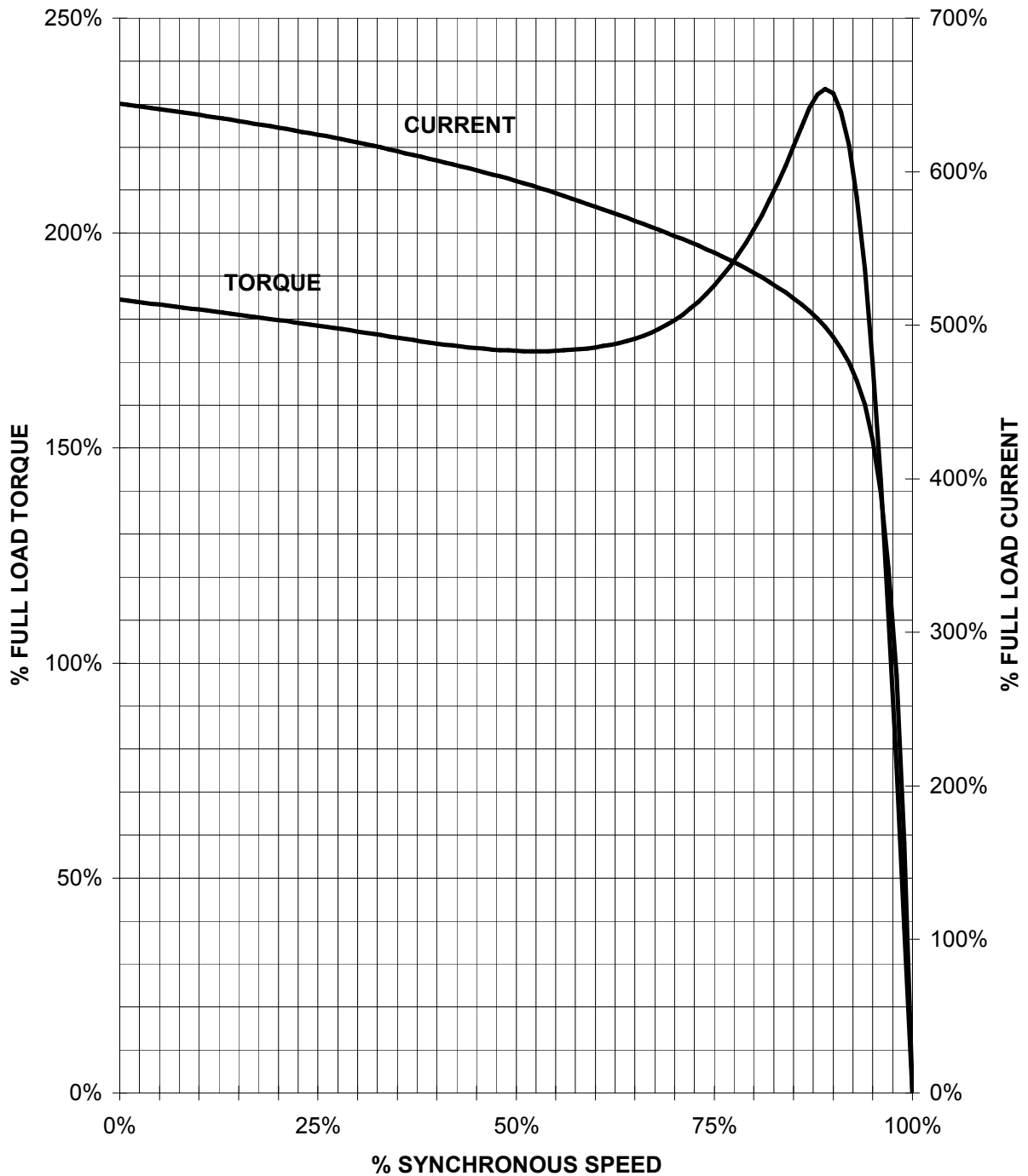

CUSTOMER: _____ ORDER#: _____

20 HP 3600 RPM 256T FRAME 460 VOLTS 3 PHASE NEMA DESIGN B

SIEMENS INDUSTRY, INC.
PERFORMANCE CURVE
GP100

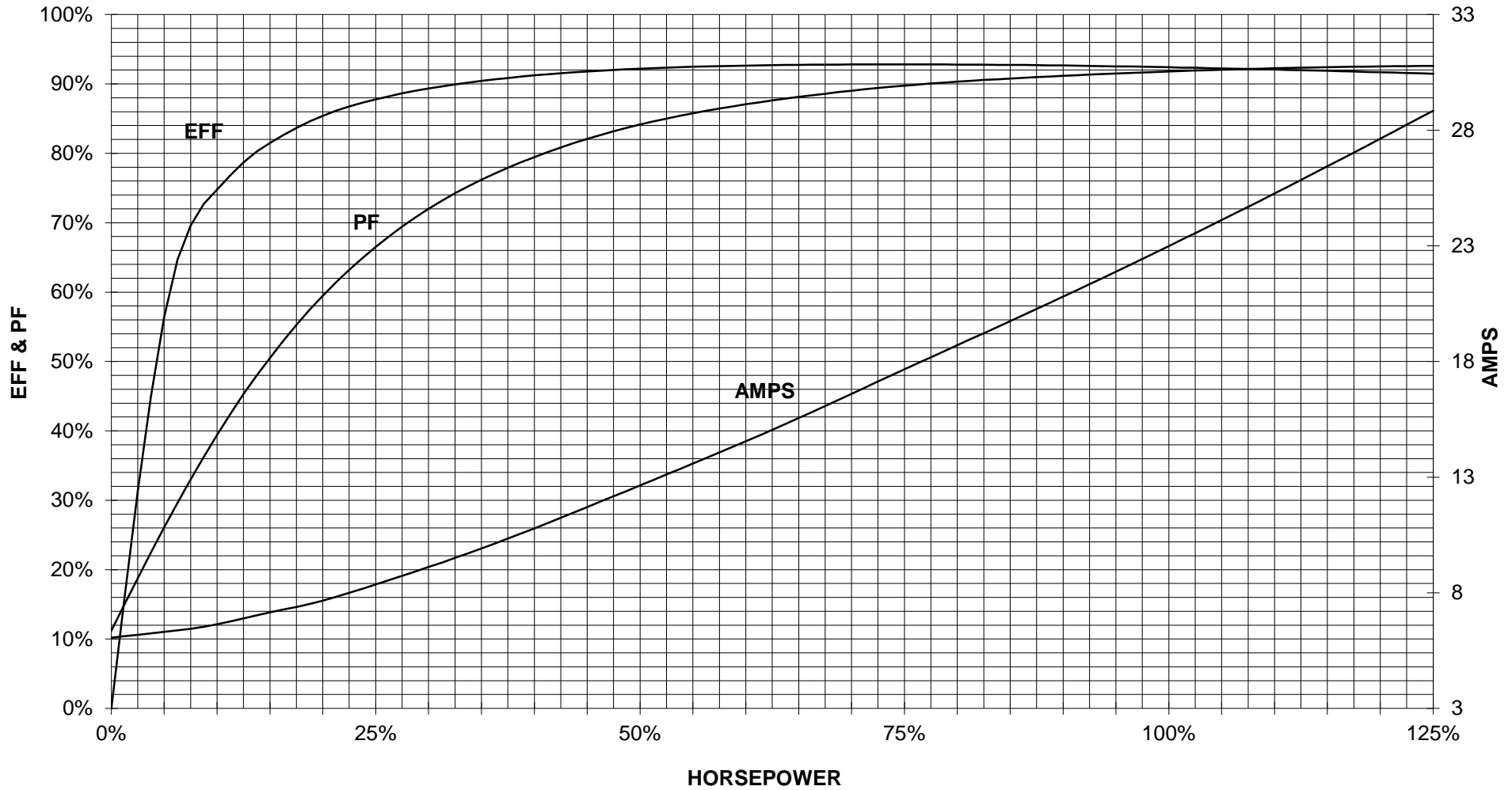

CUSTOMER _____ ORDER # _____ PO # _____

PERFORMANCE BASED ON DESIGN CALCULATIONS. SUBJECT TO CHANGE WITHOUT NOTICE.

REV. 1

Main terminal diagram



| 9 LEAD WYE | | | | | | |
|------------|----------|----------|----------|--------------------|-------|--|
| Volts | LINES | | | CONNECTED TOGETHER | CONN. | |
| | L1 | L2 | L3 | | | |
| LOW | T1
T7 | T2
T6 | T3
T9 | T4 T5 T6 | YY | |
| HIGH | T1 | T2 | T3 | T4 T7-T5 T8-T6 T9 | Y | |

| | | | | |
|-------------------------------|---------------------------------|-----------------------------|----------------|-------------|
| responsible dep.
DI MC LVM | technical reference | created by | approved by | Project |
| SIEMENS | document type
Wiring Diagram | document status
free | | customer |
| | title
1LE2221-2BA21-4EA3 | document number | | |
| © Siemens AG 2019 | rev.
01 | creation date
12/03/2019 | language
en | Page
1/1 |