

# Data sheet for three-phase Squirrel-Cage-Motors SIMOTICS

Motor type: **GP100** FS: **254T - 4p - 15 hp -**

Client order no.	Item-No.	Offer no.
Order no.	Consignment no.	Project
Remarks		

## Electrical data

U [V]	$\Delta/Y$	f [Hz]	P [HP]	P [kW]	n [rpm]	I Load [Amps]					LRC	Nom. Eff Load [%]			Pwr. Factor Load [%]			Torque [lb-ft]	T <sub>A</sub> /T <sub>N</sub> LRT [%]	T <sub>k</sub> /T <sub>N</sub> BDT [%]
						4/4	3/4	1/2	0	4/4		3/4	2/4	4/4	3/4	2/4				
575	Y	60	15.00	11.00	1,800	15.20	12.20	9.40	6.80	92.8	92.4	92.8	92.3	80.0	74.7	64.5	44.0	184	234	

Frame Type: 254T	Type of constr.: ( E ) Foot mounted - C-Face	Ins. Cl.: Standard Class F Insulation	Motor Prot.: (A) Without Protection	NEMA Des.: B	S.F.: 1.15
Mtr. WT: 242		Temp. Rise Cl.: B	Amb. Temp.: + 40 to -20 °C @1000 m	kVA: G	IP 55

## Mechanical data

Sound level (SPL / SWL) at 60 Hz	61.0 dB(A) / 73.0 dB(A)		Thickener	Polyurea					
Octave Band Center Frequencies Hertz			Safe Stall Time Hot	21 s					
	250	500	1000	2000	4000	8000	Hz	Safe Stall Time Cold	33 s
SPL@3	47.0	53.0	59.0	56.0	47.0	38.0	dB(A)	Frame material	cast iron
Moment of inertia	1.7 Lb-ft <sup>2</sup>		Color, paint shade	Standard Paint - RAL7030					
Ext Load Inertia Capability:	75.0 Lb ft <sup>2</sup>		Coating (paint finish)	Standard Alkyed + Epoxy (C2)					
<b>Bearings</b>			<b>Ventilation Type</b>						
Bearing DE   NDE	6209 ZZ C3 S0		6209 ZZ C3 S0	Method of cooling	TEFC				
Bearing_Type	Ball Bearing		Ball Bearing	Direction of rotation	Bidirectional				
AFBMA:	45BC02JPP30		45BC02JPP30	Fan Material	Polypropylen				
<b>Grease</b>			VFD	CT: 4:1 VT: 20:1					
Capacity	0.5 oz		0.5 oz	Space heaters	without				
Grease Type:	Exxon Mobile EM		Brake:	without					

## Terminal box

Lead Wire Connection	3 LEAD - WYE				Terminal box position	(3) F-1, Standard Floor Mount, T. Box LHS
Voltage	L1	L1	L1	Connected together	Material of terminal box	Aluminium
----	----	----	----	----	Cable entry	1.25" NPT
----	T1	T2	T3	----		

### Notes:

I<sub>r</sub>/I<sub>N</sub> = locked rotor current / current nominal  
M<sub>r</sub>/M<sub>N</sub> = locked rotor torque / torque nominal  
M<sub>b</sub>/M<sub>N</sub> = break down torque / nominal torque

3) Value is valid only for DOL operation with motor design IC411  
2) at rated power / at full load

responsible dep. DI MC LVM	technical reference	created by DT Configurator	approved by	<i>Technical data are subject to change! There may be discrepancies between software and hardware versions</i>	
	document type datasheet	document status released		customer	
	title 1LE2221-2BB11-3EA3	document number			
© Siemens AG 2022	rev. 01	creation date 2022-04-08 19:08	language en	Page 1/1	

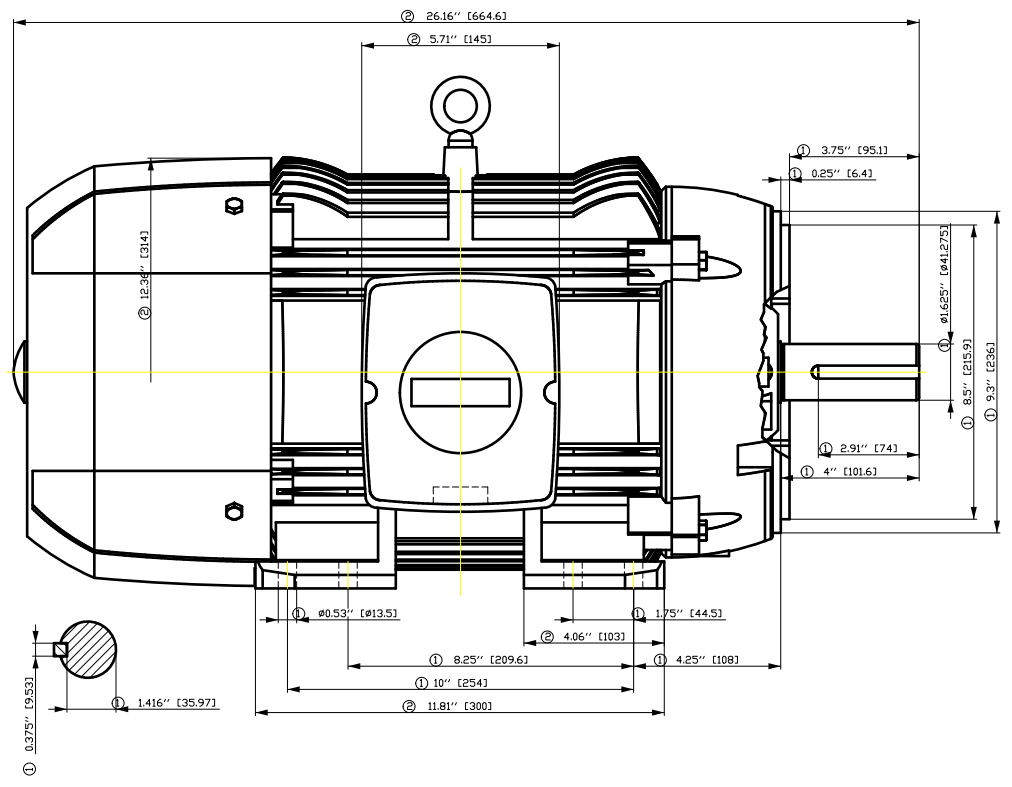
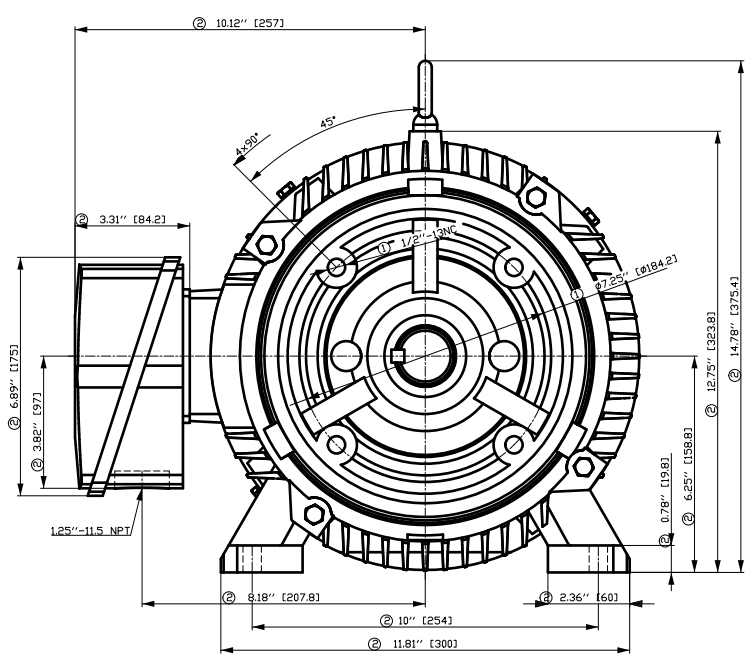

- ① Tolerances according to NEMA std.
- ② All these dimensions corresponding to assemblies and castings shall have a tolerance as per DIN standard 1686-GTB 19.
- ③ Not according to NEMA std.

Tolerance	Surface	Material	Weight	Scale
FŠÖGGFÉZÓOFFÉHÖEH É	Author Creator Approval Department Change Order	ÖS Tæ: ^æ@` }*	É	{ {
SIEMENS	Doc. State	MLFB	Doc. Type	
	Revision	Item No Doc No	Paper Size	CH
© Siemens AG 2018	Index	Ref No	1st Language 2nd Language	^ ) â ^
	Project No	É	Sheet	F of F

# SIEMENS INDUSTRY, INC.

HP 15 VOLTS < 600V RPM 1800 TYPE GP100  
HZ 60 PHASE 3 FRAME 254T NEMA B

## TORQUE & CURRENT VS. SPEED

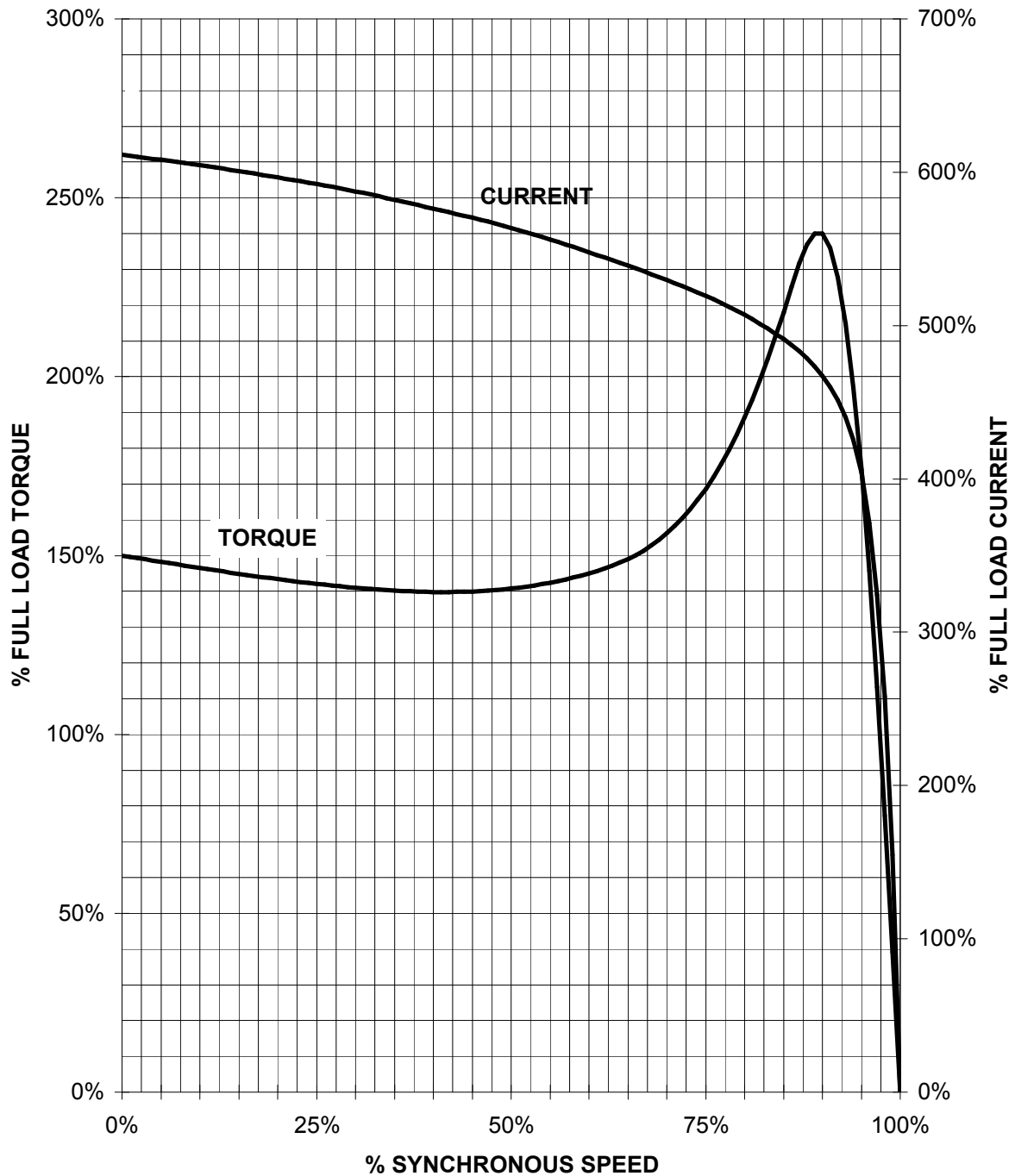

CUSTOMER: \_\_\_\_\_ ORDER#: \_\_\_\_\_

15 HP 1800 RPM 254T FRAME 575 VOLTS 3 PHASE NEMA DESIGN B

**SIEMENS INDUSTRY, INC.**  
**PERFORMANCE CURVE**  
**GP100**

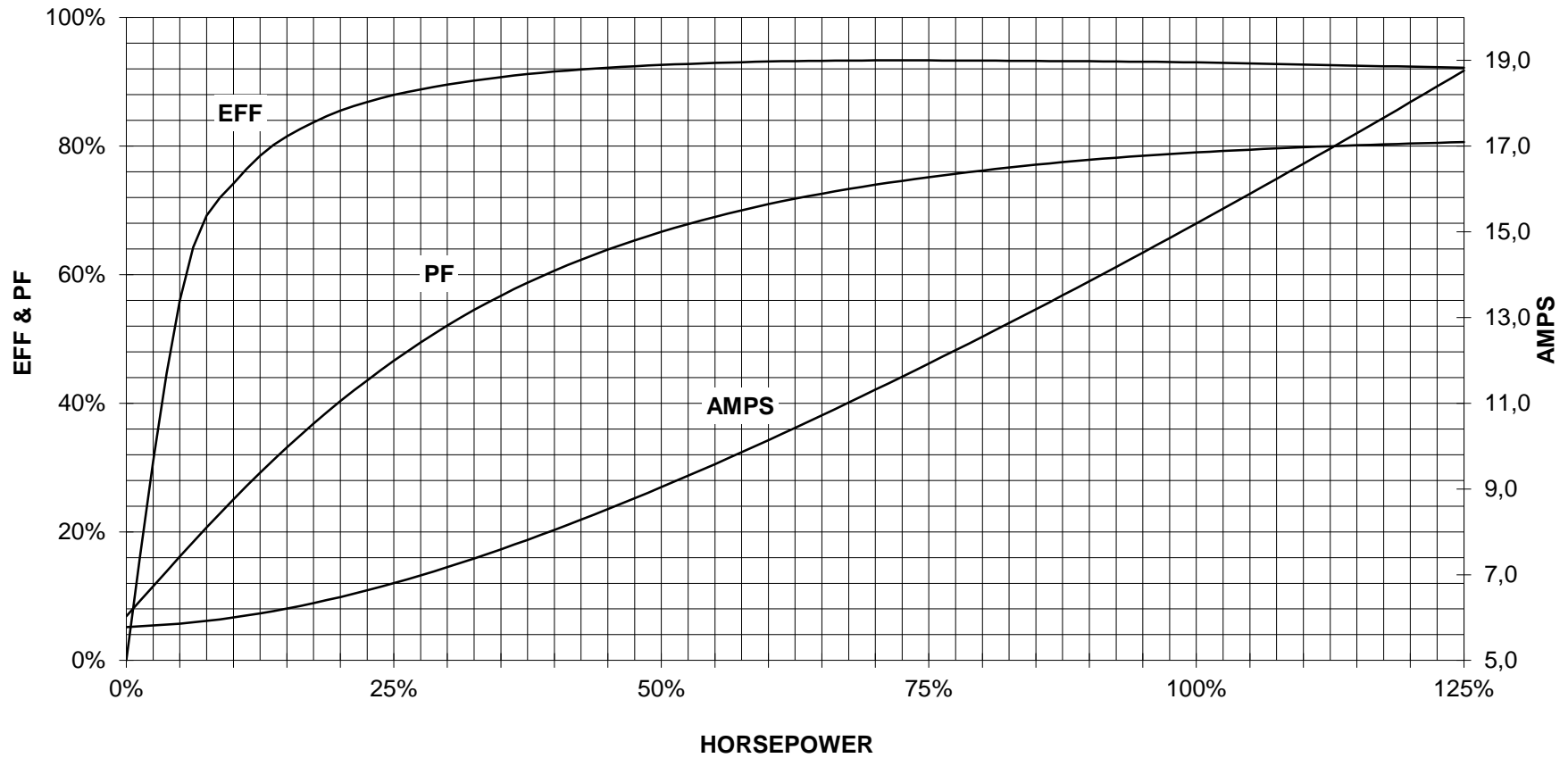

CUSTOMER \_\_\_\_\_ ORDER # \_\_\_\_\_ PO # \_\_\_\_\_

PERFORMANCE BASED ON DESIGN CALCULATIONS. SUBJECT TO CHANGE WITHOUT NOTICE.

REV. 1

Main terminal diagram

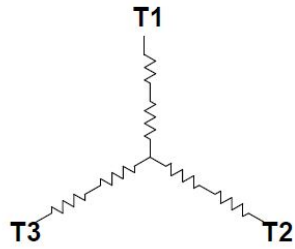

3 LEAD WYE			
LINES			CONN.
L1	L2	L3	
T1	T2	T3	

responsible dep. DI MC LVM	technical reference	created by	approved by	Project
<b>SIEMENS</b>	document type Wiring Diagram	document status free		customer
	title 1LE2221-2BB11-3EA3	document number		
© Siemens AG 2019	rev. 01	creation date 12/03/2019	language en	Page 1/1