

# Data sheet for three-phase Squirrel-Cage-Motors SIMOTICS

Motor type: **GP100** FS: **254T - 6p - 7.5 hp -**

Client order no.	Item-No.	Offer no.
Order no.	Consignment no.	Project
Remarks		

## Electrical data

U [V]	$\Delta/Y$	f [Hz]	P [HP]	P [kW]	n [rpm]	I Load [Amps]					LRC	Nom. Eff Load [%]			Pwr. Factor Load [%]			Torque [lb-ft]	T <sub>A</sub> /T <sub>N</sub> LRT [%]	T <sub>k</sub> /T <sub>N</sub> BDT [%]
						4/4	3/4	1/2	0	4/4		3/4	2/4	4/4	3/4	2/4				
575	Y	60	7.50	5.50	1,200	8.00	6.60	5.30	4.00	50.4	91.0	91.5	91.1	77.2	70.2	58.4	33.0	167	261	

**without**

Frame Type: 254T	Type of constr.: ( E ) Foot mounted - C-Face	Ins. Cl.:Standard Class F Insulation	Motor Prot.:(A) Without Protection	NEMA Des.: B	S.F.: 1.15
Mtr. WT:249		Temp. Rise Cl.: B	Amb. Temp.: + 40 to -20 °C @1000 m	kVA: H	IP 55

## Mechanical data

Sound level (SPL / SWL) at 60 Hz	55.0 dB(A) / 67.0 dB(A)							Thickener	Polyurea
Octave Band Center Frequencies Hertz								Safe Stall Time Hot	26 s
	250	500	1000	2000	4000	8000	Hz	Safe Stall Time Cold	45 s
SPL@3	40.0	42.0	51.0	46.0	51.0	28.0	dB(A)	Frame material	cast iron
Moment of inertia	1.5 Lb-ft <sup>2</sup>							Color, paint shade	Standard Paint - RAL7030
Ext Load Inertia Capability:	104.0 Lb ft <sup>2</sup>							Coating (paint finish)	Standard Alkyed + Epoxy (C2)
<b>Bearings</b>								<b>Ventilation Type</b>	
Bearing DE   NDE	6209 ZZ C3 S0			6209 ZZ C3 S0				Method of cooling	TEFC
Bearing_Type	Ball Bearing			Ball Bearing				Direction of rotation	Bidirectional
AFBMA:	45BC02JPP30			45BC02JPP30				Fan Material	Polypropylen
<b>Grease</b>								VFD	CT: 4:1 VT: 20:1
Capacity	0.5 oz			0.5 oz				Space heaters	without
Grease Type:	Exxon Mobile EM							Brake:	without

## Terminal box

Lead Wire Connection	3 LEAD - WYE				Terminal box position	(3) F-1, Standard Floor Mount, T. Box LHS
Voltage	L1	L1	L1	Connected together	Material of terminal box	Aluminium
----	----	----	----	----	Cable entry	1.25" NPT
----	T1	T2	T3	----		

### Notes:

I<sub>r</sub>/I<sub>N</sub> = locked rotor current / current nominal  
M<sub>r</sub>/M<sub>N</sub> = locked rotor torque / torque nominal  
M<sub>b</sub>/M<sub>N</sub> = break down torque / nominal torque

3) Value is valid only for DOL operation with motor design IC411  
2) at rated power / at full load

responsible dep. DI MC LVM	technical reference	created by DT Configurator	approved by	<i>Technical data are subject to change! There may be discrepancies between software and hardware versions</i>	
	document type datasheet	document status released	customer		
	title 1LE2221-2BC11-3EA3	document number			
© Siemens AG 2022	rev. 01	creation date 2022-04-08 19:13	language en	Page 1/1	

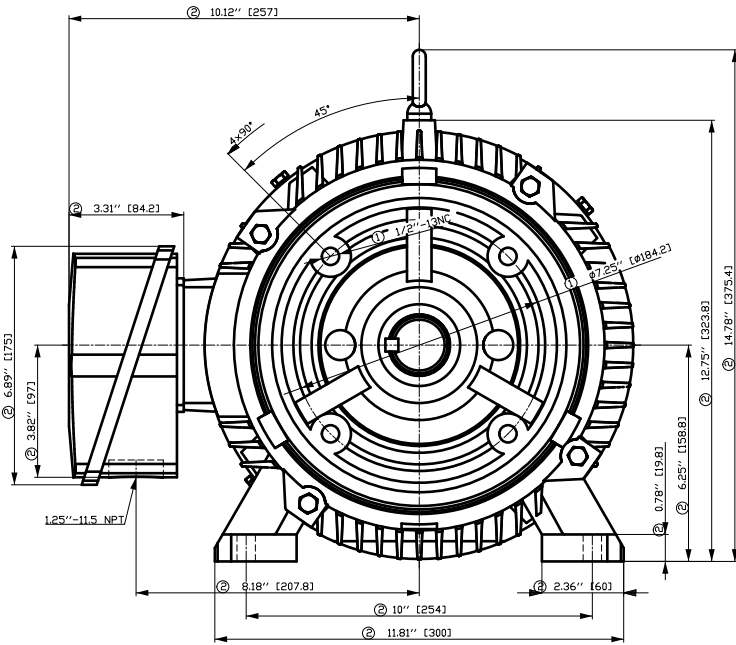

- ① Tolerances according to NEMA std.
- ② All these dimensions corresponding to assemblies and castings shall have a tolerance as per DIN standard 1686-GTB 19.
- ③ Not according to NEMA std.

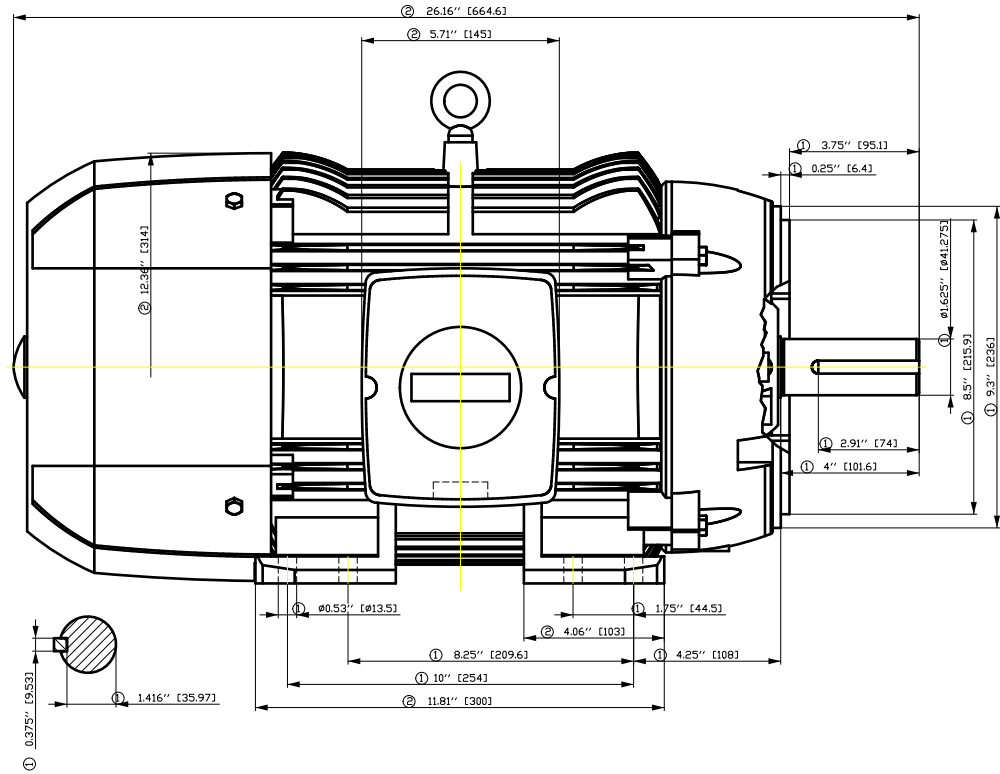

Tolerance	Surface	Material	Weight	Scale
F5ÖGGFÉZÖÖFFÉÖEH	Author	ÖV	ÖV	ÖV
É	Creator	ÖV	ÖV	ÖV
	Approval	T: ^@~}		
	Department			
	Change Order	MFB	Doc Type	/
	Doc State	I ð BGG	Item No	Paper Size ÖH
	Revision	Index RS	Doc No	1st Language ^}
				2nd Language ä^
© Siemens AG 2018	Project No	É	Ref No	É
				Sheet F of F

# SIEMENS INDUSTRY, INC.

HP 7,5 VOLTS < 600V RPM 1200 TYPE GP100  
HZ 60 PHASE 3 FRAME 254T NEMA B

## TORQUE & CURRENT VS. SPEED

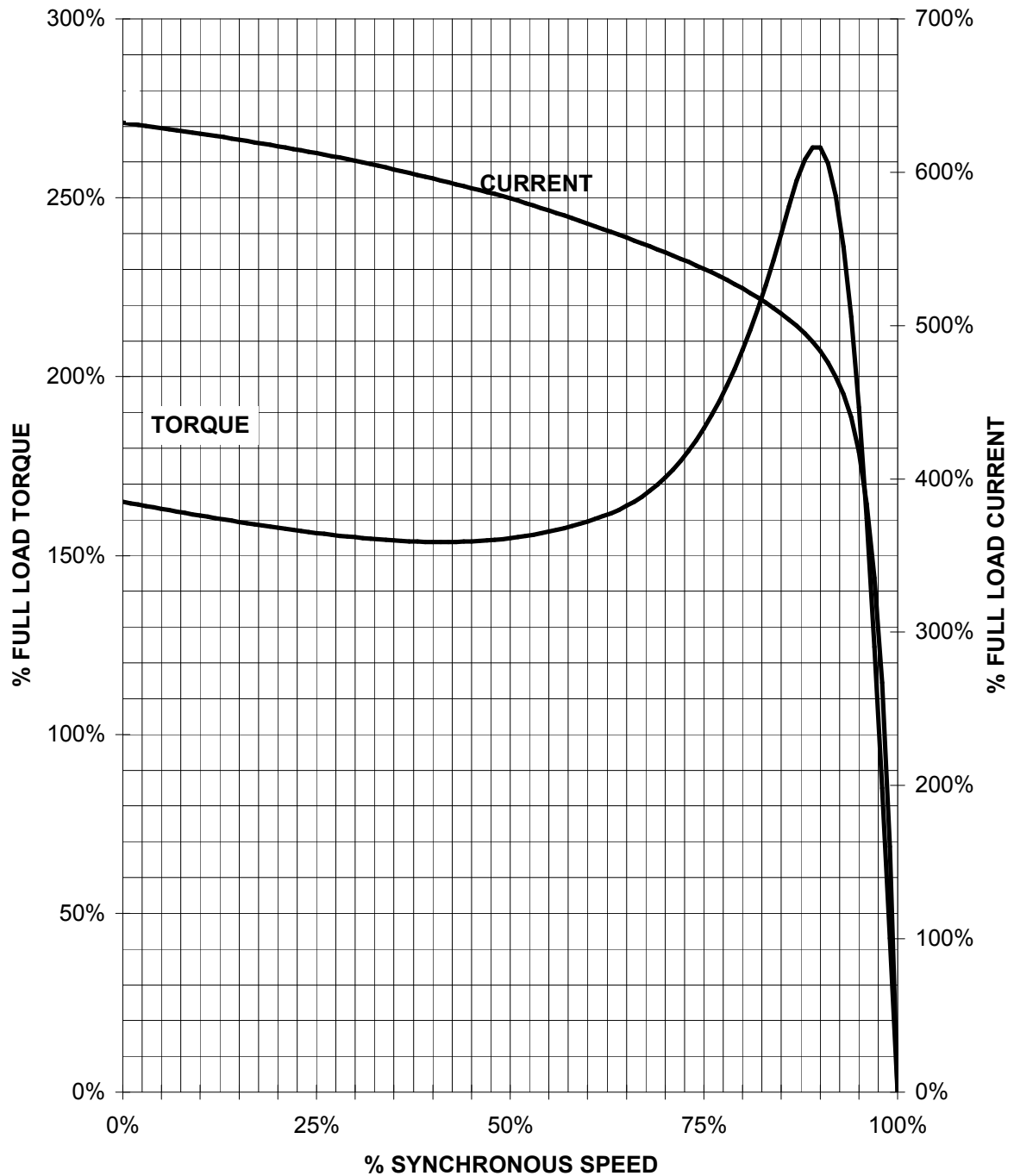

CUSTOMER: \_\_\_\_\_ ORDER#: \_\_\_\_\_

7.5 HP 1200 RPM 254T FRAME 575 VOLTS 3 PHASE NEMA DESIGN B

**SIEMENS INDUSTRY, INC.**  
**PERFORMANCE CURVE**  
**GP100**

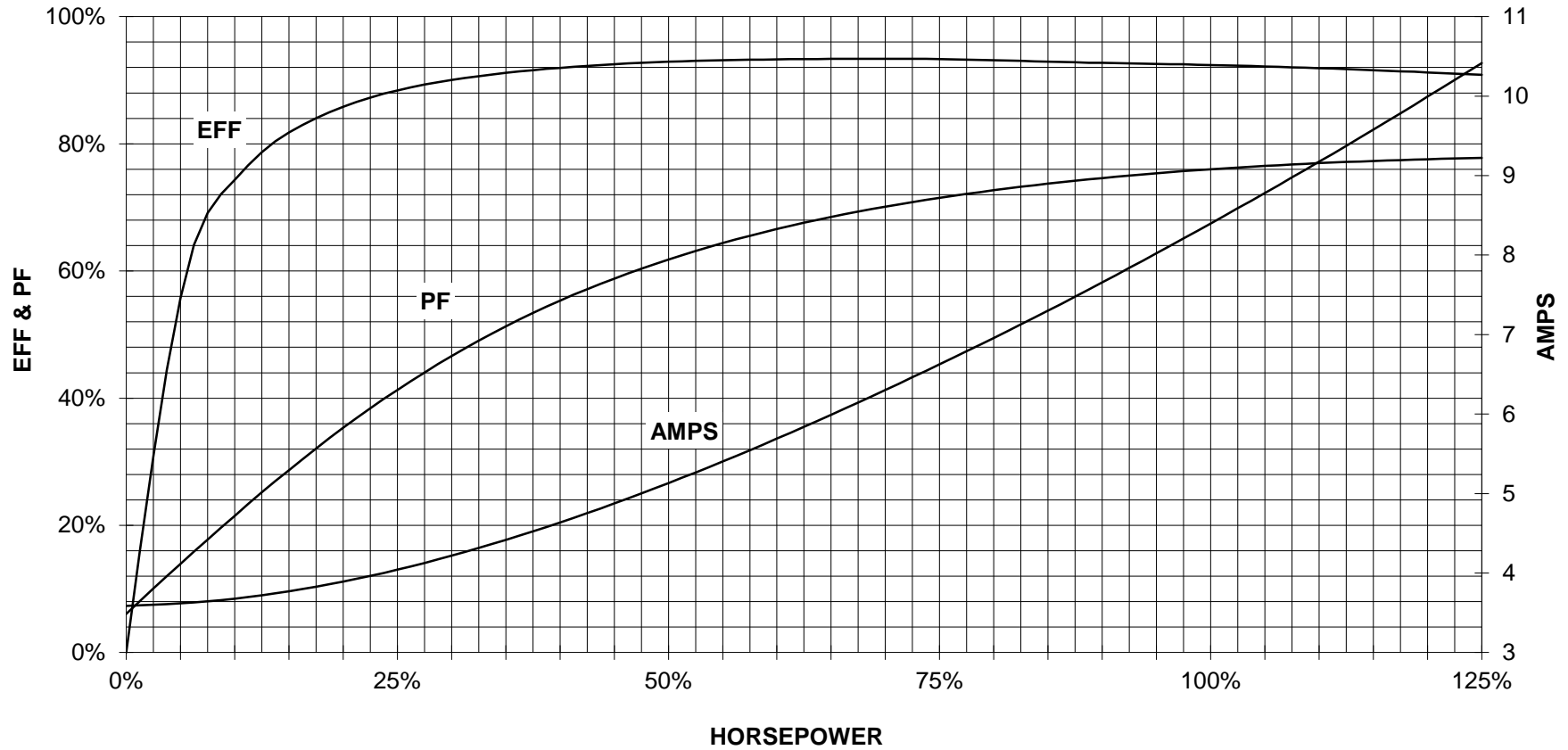

CUSTOMER \_\_\_\_\_ ORDER # \_\_\_\_\_ PO # \_\_\_\_\_

PERFORMANCE BASED ON DESIGN CALCULATIONS. SUBJECT TO CHANGE WITHOUT NOTICE.

REV. 1

Main terminal diagram

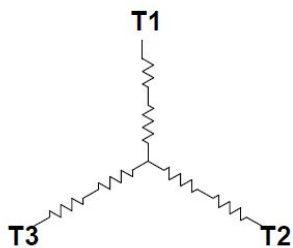

3 LEAD WYE			
LINES			CONN.
L1	L2	L3	
T1	T2	T3	

responsible dep. DI MC LVM	technical reference	created by	approved by	Project			
	document type Wiring Diagram			document status free		customer	
	title 1LE2221-2BC11-3EA3			document number			
© Siemens AG 2019				rev. 01	creation date 12/03/2019	language en	Page 1/1