

Data sheet for three-phase Squirrel-Cage-Motors SIMOTICS

Motor type: **GP100** FS: **286T - 4p - 30 hp -**

Client order no.	Item-No.	Offer no.
Order no.	Consignment no.	Project

Remarks

Electrical data

U [V]	Δ/Y	f [Hz]	P [HP]	P [kW]	n [rpm]	I Load [Amps]					LRC	Nom. Eff Load [%]			Pwr. Factor Load [%]			Torque [lb-ft]	T _A /T _N LRT [%]	T _k /T _N BDT [%]
						4/4	3/4	1/2	0	4/4		3/4	2/4	4/4	3/4	2/4				
460	Δ	60	30.00	22.00	1,800	35.00	27.30	20.50	12.00	218.0	93.6	94.1	93.9	85.0	82.0	73.0	89.0	180	251	
230	$\Delta\Delta$	60	30.00	22.00	1,800	70.00	54.61	40.98	24.00	436.0	93.6	94.1	93.9	85.0	82.0	73.0	89.0	180	251	
400	Δ	50	25.00		1,476	34.76	27.41	21.12	14.17	230.8	92.6	93.3	93.1	82.9	78.2	67.8	89.0	201	313	
200	$\Delta\Delta$	50	25.00		1,476	69.52	54.82	42.24	28.34	461.6	92.6	93.3	93.1	82.9	78.2	67.8	89.0	201	313	

Frame Type: 286T	Type of constr.: (A) Foot mounted - End shield	Ins. Cl.: Standard Class F Insulation	Motor Prot.: (A) Without Protection	NEMA Des.: B	S.F.: 1.15
Mtr. WT: 456		Temp. Rise Cl.: B	Amb. Temp.: + 40 to -20 °C @1000 m	kVA: G	IP 54

Mechanical data

Sound level (SPL / SWL) at 60 Hz	65.0 dB(A) / 76.0 dB(A)							Thickener	Polyurea
Octave Band Center Frequencies Hertz								Safe Stall Time Hot	24 s
	250	500	1000	2000	4000	8000	Hz	Safe Stall Time Cold	44 s
SPL@3	51.0	55.0	55.0	62.0	59.0	51.0	dB(A)	Frame material	cast iron
Moment of inertia	4.8 Lb-ft ²							Color, paint shade	Standard Paint - RAL7030
Ext Load Inertia Capability:	144.0 Lb ft ²							Coating (paint finish)	Standard Alkyed + Epoxy (C2)
Bearings								Ventilation Type	
Bearing DE NDE	6310 Z C3 S0			6210 ZZ C3 S0				Method of cooling	TEFC
Bearing_Type	Ball Bearing			Ball Bearing				Direction of rotation	Bidirectional
AFBMA:	50BC03JP30			50BC02JPP30				Fan Material	Polypropylen ESD
Grease								VFD	CT: 4:1 VT: 20:1
Capacity	2.6 oz			2.3 oz				Space heaters	without
Grease Type:	Exxon Mobile EM							Brake:	without

Terminal box

Lead Wire Connection	9 LEAD - DELTA				Terminal box position	(3) F-1, Standard Floor Mount, T. Box LHS
Voltage	L1	L1	L1	Connected together	Material of terminal box	Stamped Steel
LOW	T1 T7 T6	T2 T8 T4	T3 T9 T5	---	Cable entry	1.5" NPT
HIGH	T1	T2	T3	T4 T7-T5 T8-T6 T9		

Notes:

I_L/I_N = locked rotor current / current nominal
M_L/M_N = locked rotor torque / torque nominal
M_d/M_N = break down torque / nominal torque

3) Value is valid only for DOL operation with motor design IC411
2) at rated power / at full load

responsible dep. DI MC LVM	technical reference	created by DT Configurator	approved by	<i>Technical data are subject to change! There may be discrepancies between our website and our data sheets.</i>
-------------------------------	---------------------	-------------------------------	-------------	--

	document type datasheet	document status released	customer	
	title 1LE2221-2CB21-6AA3	document number	rev. 01	creation date 2022-04-08 20:28
© Siemens AG 2022				Page 1/1

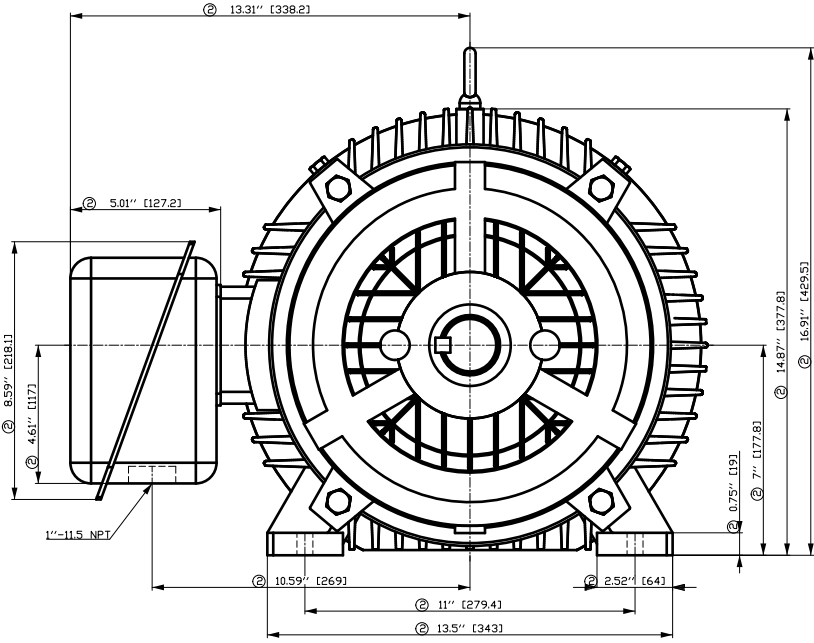

- ① Tolerances according to NEMA std.
- ② All these dimensions corresponding to assemblies and castings shall have a tolerance as per DIN standard 1686-GTB 19.
- ③ Not according to NEMA std.

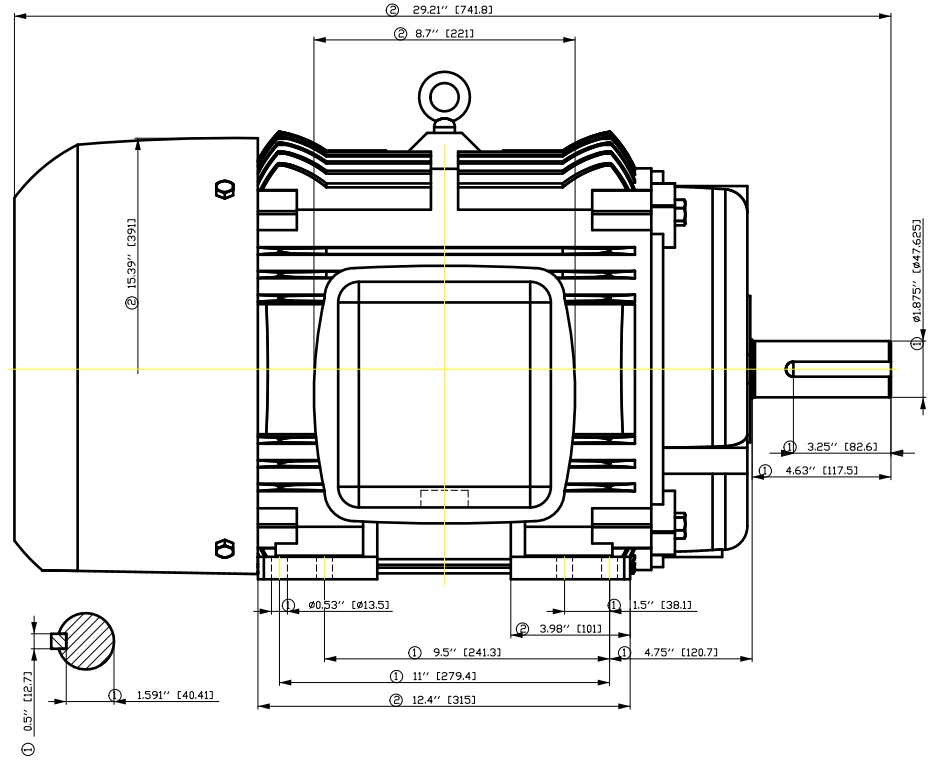

Tolerance	Surface	Material	Weight	Scale
F50CGGF300GF010EH E	Author Creator Approval Department Change Order	ÖVS T a : ^ & @ } *	E	{ {
SIEMENS	Doc. State Revision	Item No Doc No	Doc Type Paper Size	1st Language 2nd Language
© Siemens AG 2018	Project No E	Ref No E	Sheet F of F	

SIEMENS INDUSTRY, INC.

HP 30 VOLTS < 600V RPM 1800 TYPE GP100
HZ 60 PHASE 3 FRAME 286T NEMA B

TORQUE & CURRENT VS. SPEED

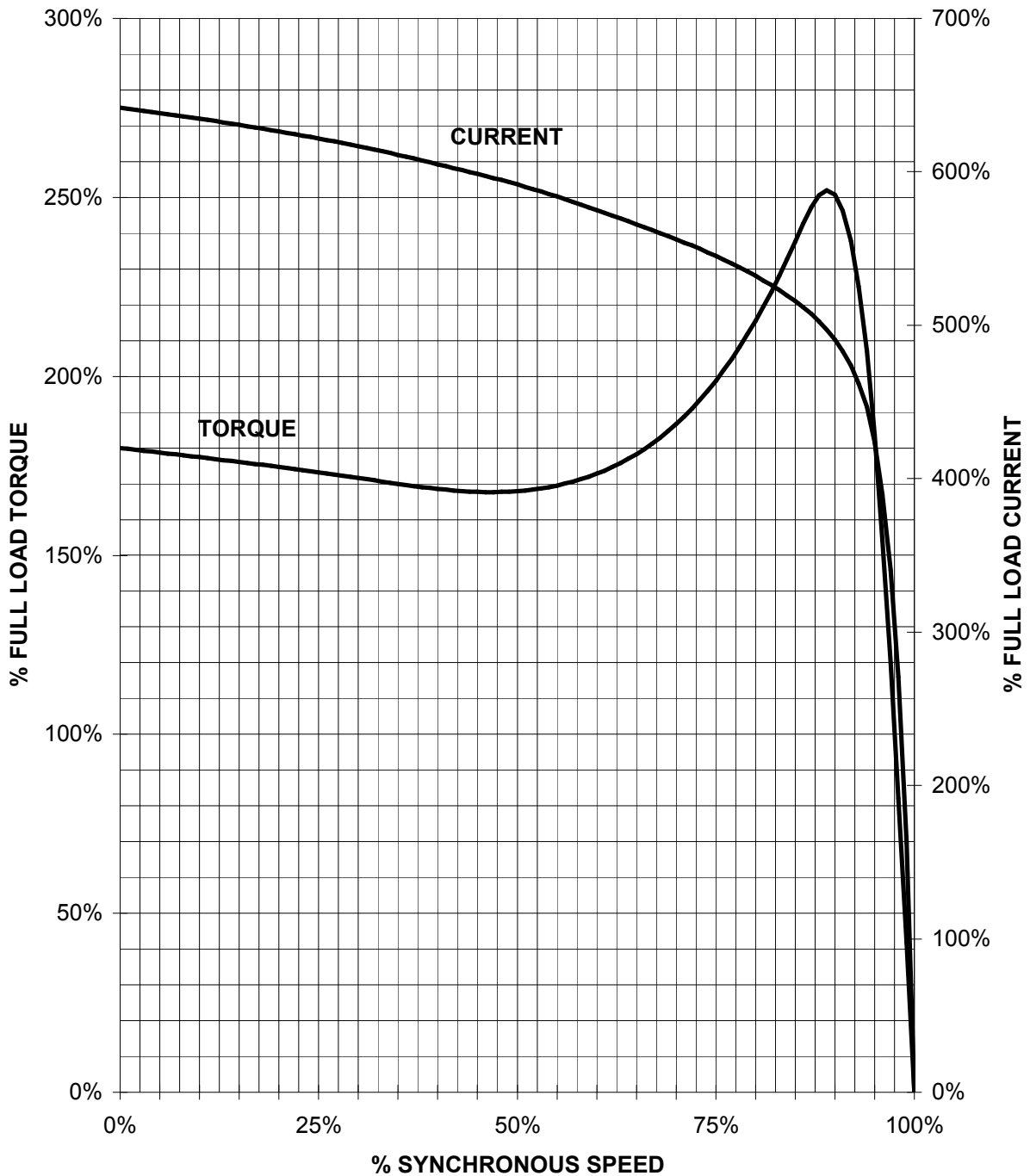

CUSTOMER: _____ ORDER#: _____

30 HP 1800 RPM 286T FRAME 460 VOLTS 3 PHASE NEMA DESIGN B

SIEMENS INDUSTRY, INC.
PERFORMANCE CURVE
GP100

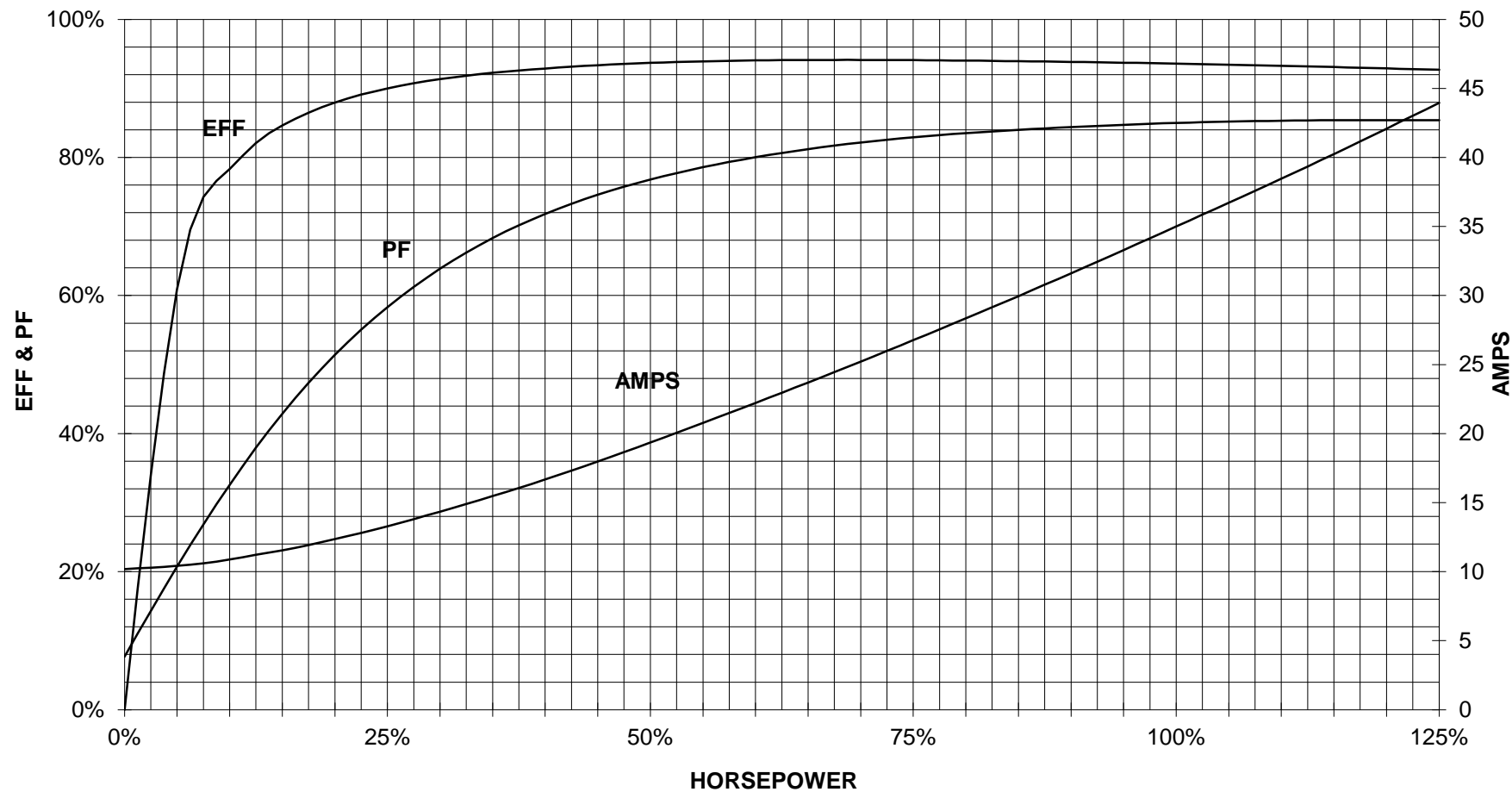

CUSTOMER _____ ORDER # _____ PO # _____

PERFORMANCE BASED ON DESIGN CALCULATIONS. SUBJECT TO CHANGE WITHOUT NOTICE.

REV. 1

Main terminal diagram

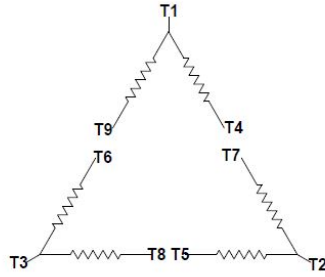

9 LEAD DELTA						
Volts	LINES			CONNECTED TOGETHER	CONN.	
	L1	L2	L3			
LOW	T1 T6	T7 T4	T8 T5	T3 T9		Δ Δ
HIGH	T1	T2	T3	T4 T7-T5 T8-T6 T9		Δ

responsible dep. DI MC LVM	technical reference	created by	approved by	Project
SIEMENS	document type Wiring Diagram	document status free		customer
	title 1LE2221-2CB21-6AA3	document number		
© Siemens AG 2019	rev. 01	creation date 12/03/2019	language en	Page 1/1