

Data sheet for three-phase Squirrel-Cage-Motors SIMOTICS

Motor type: **GP100** FS: **324T - 8p - 20 hp -**

Client order no.	Item-No.	Offer no.
Order no.	Consignment no.	Project
Remarks		

Electrical data

U [V]	Δ / Y	f [Hz]	P [HP]	P [kW]	n [rpm]	I Load [Amps]					LRC	Nom. Eff Load [%]			Pwr. Factor Load [%]			Torque [lb-ft]	T _A /T _N LRT [%]	T _k /T _N BDT [%]
						4/4	3/4	1/2	0	4/4		3/4	2/4	4/4	3/4	2/4				
575	Δ	60	20.00	15.00	900	25.60	21.30	18.10	14.40	116.0	91.0	90.8	90.0	65.0	58.0	46.0	119.0	139	200	

without

Frame Type: 324T	Type of constr.: (A) Foot mounted - End shield	Ins. Cl.: Standard Class F Insulation	Motor Prot.: (A) Without Protection	NEMA Des.: B	S.F.: 1.15
Mtr. WT: 616		Temp. Rise Cl.: B	Amb. Temp.: + 40 to -20 °C @1000 m	kVA: G	IP 54

Mechanical data

Sound level (SPL / SWL) at 60 Hz	57.0 dB(A) / 67.0 dB(A)		Thickener	Polyurea					
Octave Band Center Frequencies Hertz			Safe Stall Time Hot	15 s					
	250	500	1000	2000	4000	8000	Hz	Safe Stall Time Cold	35 s
SPL@3	53.0	55.0	56.0	53.0	41.0	32.0	dB(A)	Frame material	cast iron
Moment of inertia	8.8 Lb-ft ²		Color, paint shade	Standard Paint - RAL7030					
Ext Load Inertia Capability:	525.0 Lb ft ²		Coating (paint finish)	Standard Alkyed + Epoxy (C2)					
Bearings			Ventilation Type						
Bearing DE NDE	6312 Z C3 S0		6210 ZZ C3 S0	Method of cooling	TEFC				
Bearing_Type	Ball Bearing		Ball Bearing	Direction of rotation	Bidirectional				
AFBMA:	60BC03JP30		50BC02JPP30	Fan Material	Polypropylen ESD				
Grease			VFD	CT: 4:1 VT: 20:1					
Capacity	5.5 oz		2.3 oz	Space heaters	without				
Grease Type:	Exxon Mobile EM		Brake:	without					

Terminal box

Lead Wire Connection	3 LEAD - DELTA				Terminal box position	(3) F-1, Standard Floor Mount, T. Box LHS
Voltage	L1	L1	L1	Connected together	Material of terminal box	Stamped Steel
----	----	----	----	----	Cable entry	2" NPT
----	T1	T2	T3	----		

Notes:

I_r/I_N = locked rotor current / current nominal
M_r/M_N = locked rotor torque / torque nominal
M_b/M_N = break down torque / nominal torque

3) Value is valid only for DOL operation with motor design IC411
2) at rated power / at full load

responsible dep. DI MC LVM	technical reference	created by DT Configurator	approved by	<i>Technical data are subject to change! There may be discrepancies between software and hardware versions</i>	
	document type datasheet	document status released	customer		
	title 1LE2221-3AD11-3AA3	document number			
© Siemens AG 2022	rev. 01	creation date 2022-04-08 21:11	language en	Page 1/1	

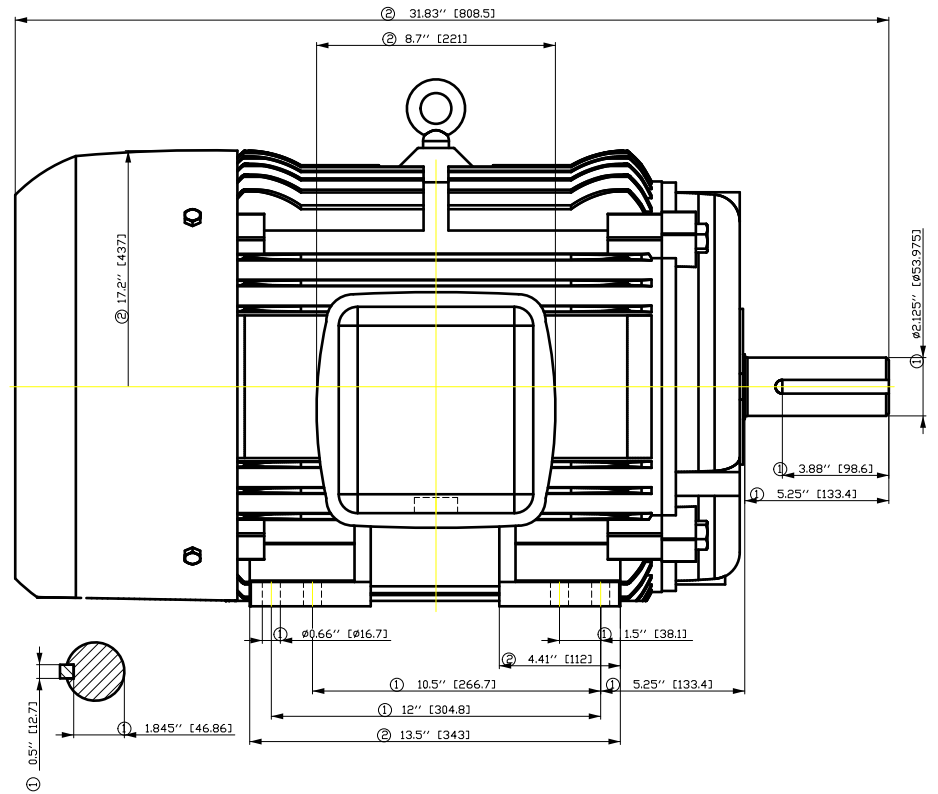
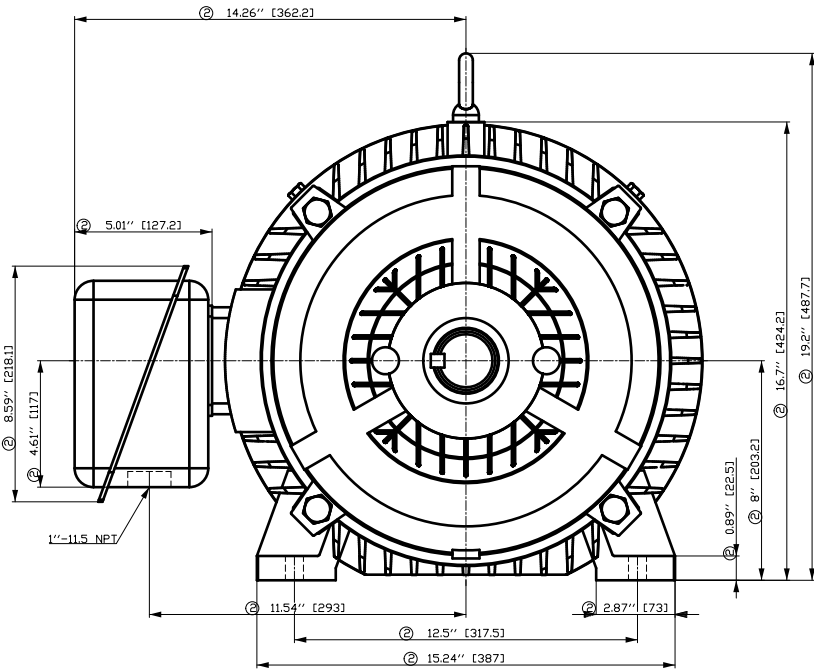

- ① Tolerances according to NEMA std.
- ② All these dimensions corresponding to assemblies and castings shall have a tolerance as per DIN standard 1686-GTB 19.
- ③ Not according to NEMA std.

Tolerance	Surface	Material	Weight	Scale
F50GGGF-00FFH00H E	Author Creator Approval Department Change Order	ÖS T a : ^ & @ } *	E	{ {
SIEMENS	Doc. State	I B B G	Doc Type	/
	Revision	Index RS	Paper Size	CH
	Project No	E	1st Language	^
			2nd Language	â
© Siemens AG 2018	Item No	Doc No	Ref No	E
	Sheet	F of F		

SIEMENS INDUSTRY, INC.

HP 20 VOLTS < 600V RPM 900 TYPE GP100
HZ 60 PHASE 3 FRAME 324T NEMA B

TORQUE & CURRENT VS. SPEED

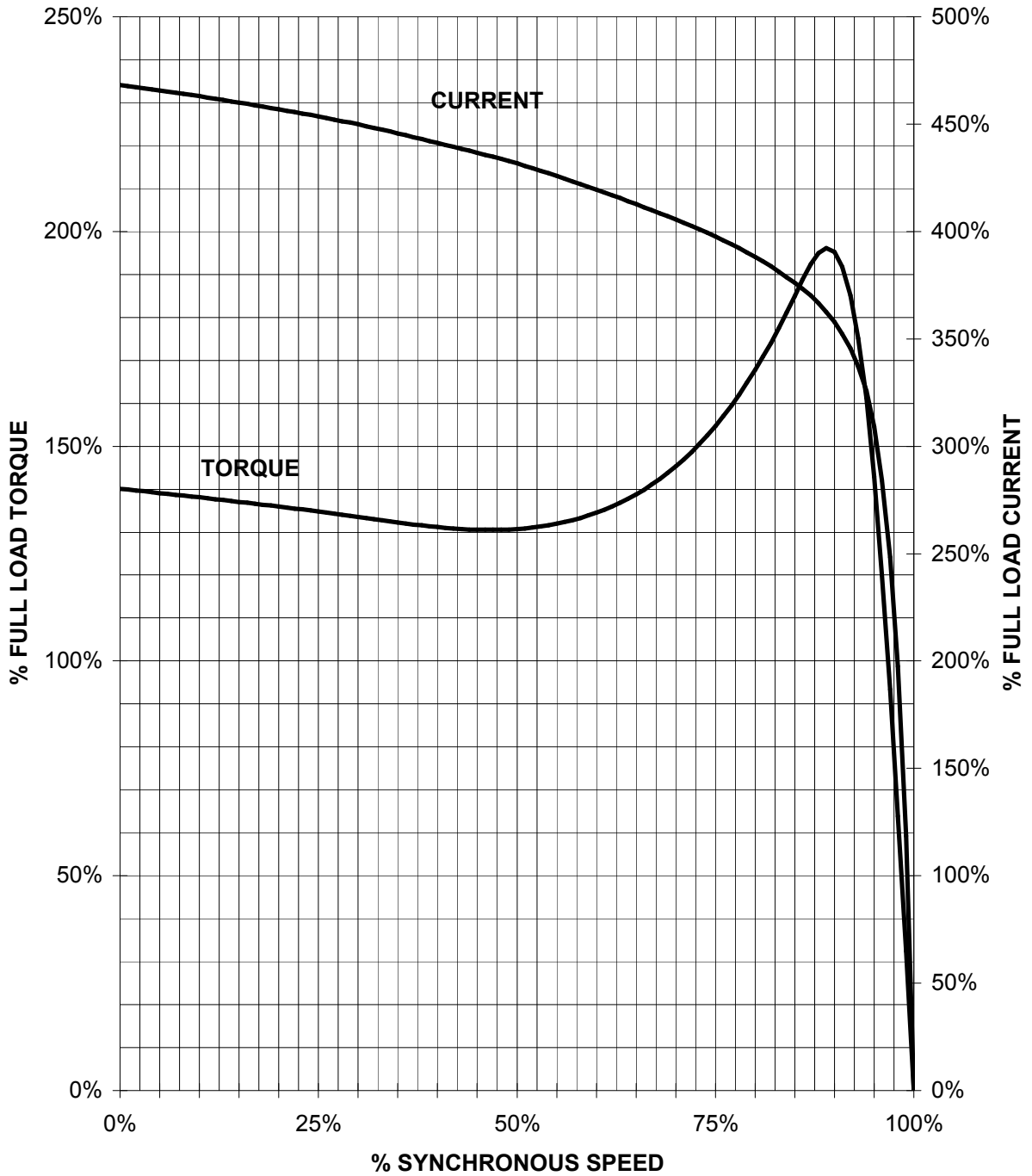

CUSTOMER: _____ ORDER#: _____

20 HP 900 RPM 324T FRAME 575 VOLTS 3 PHASE NEMA DESIGN B

SIEMENS INDUSTRY, INC.
PERFORMANCE CURVE
GP100

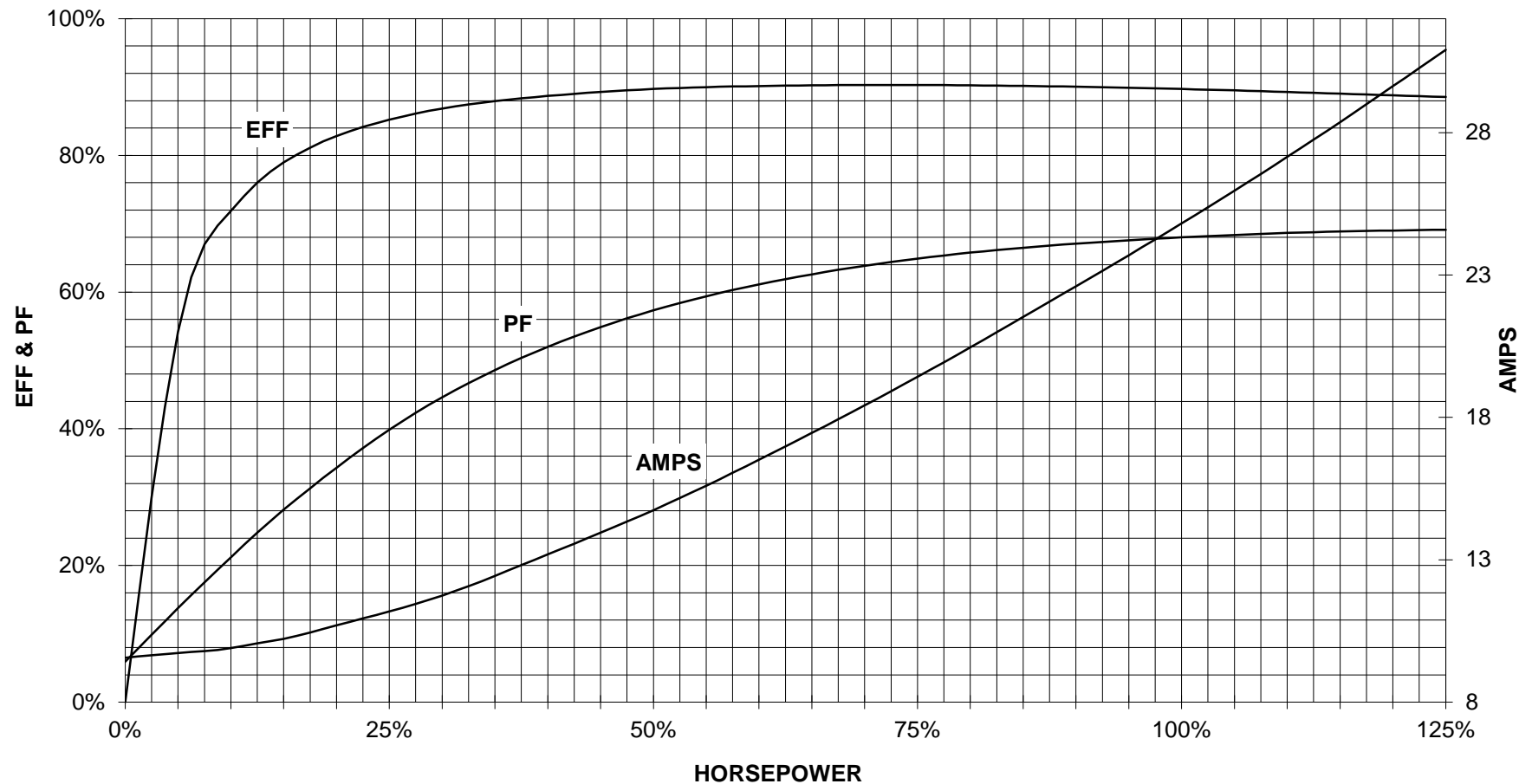

CUSTOMER: _____ ORDER #: _____

PERFORMANCE BASED ON DESIGN CALCULATIONS. SUBJECT TO CHANGE WITHOUT NOTICE.

REV. 1

Main terminal diagram



3 LEAD DELTA			
LINES			CONN.
L1	L2	L3	
T1	T2	T3	Δ

responsible dep. DI MC LVM	technical reference	created by	approved by	Project		
	document type Wiring Diagram		document status free		customer	
	title 1LE2221-3AD11-3AA3		document number			
© Siemens AG 2019			rev. 01	creation date 12/03/2019	language en	Page 1/1