

Data sheet for three-phase Squirrel-Cage-Motors SIMOTICS

Motor type: **GP100** FS: **326TS - 2p - 50 hp -**

Client order no.	Item-No.	Offer no.
Order no.	Consignment no.	Project
Remarks		

Electrical data

U [V]	Δ / Y	f [Hz]	P [HP]	P [kW]	n [rpm]	I Load [Amps]					LRC	Nom. Eff Load [%]			Pwr. Factor Load [%]			Torque [lb-ft]	T _A /T _N LRT [%]	T _k /T _N BDT [%]
						4/4	3/4	1/2	0	4/4		3/4	2/4	4/4	3/4	2/4				
460	Δ	60	50.00	37.00	3,600	55.00	41.90	30.40	15.00	363.0	93.6	94.1	93.8	91.0	89.0	82.0	74.0	150	250	
230	$\Delta \Delta$	60	50.00	37.00	3,600	110.00	83.85	60.87	30.00	726.0	93.6	94.1	93.8	91.0	89.0	82.0	74.0	150	250	
400	Δ	50	40.00		2,968	54.80	44.70	36.20	27.90	336.0	93.3	93.8	93.5	87.2	81.9	70.8	70.9	180	285	
200	$\Delta \Delta$	50	40.00		2,968	109.60	89.40	72.40	55.80	672.0	93.3	93.8	93.5	87.2	81.9	70.8	70.9	180	285	

Frame Type: 326TS	Type of constr.: (A) Foot mounted - End shield	Ins. Cl.: Standard Class F Insulation	Motor Prot.: (A) Without Protection	NEMA Des.: B	S.F.: 1.15
Mtr. WT: 593		Temp. Rise Cl.: B	Amb. Temp.: + 40 to -20 °C @1000 m	kVA: G	IP 54

Mechanical data

Sound level (SPL / SWL) at 60 Hz	77.0 dB(A) / 87.0 dB(A)							Thickener	Polyurea
Octave Band Center Frequencies Hertz								Safe Stall Time Hot	18 s
	250	500	1000	2000	4000	8000	Hz	Safe Stall Time Cold	37 s
SPL@3	56.0	68.0	68.0	70.0	74.0	54.0	dB(A)	Frame material	cast iron
Moment of inertia	3.6 Lb-ft ²							Color, paint shade	Standard Paint - RAL7030
Ext Load Inertia Capability:	49.0 Lb ft ²							Coating (paint finish)	Standard Alkyed + Epoxy (C2)
Bearings								Ventilation Type	
Bearing DE NDE	6312 Z C3 S0			6210 ZZ C3 S0				Method of cooling	TEFC
Bearing_Type	Ball Bearing			Ball Bearing				Direction of rotation	Bidirectional
AFBMA:	60BC03JP30			50BC02JPP30				Fan Material	Polypropylen ESD
Grease								VFD	CT: 4:1 VT: 20:1
Capacity	5.5 oz			2.3 oz				Space heaters	without
Grease Type:	Exxon Mobile EM							Brake:	without

Terminal box

Lead Wire Connection	9 LEAD - DELTA				Terminal box position	(3) F-1, Standard Floor Mount, T. Box LHS
Voltage	L1	L1	L1	Connected together	Material of terminal box	Stamped Steel
LOW	T1 T7 T6	T2 T8 T4	T3 T9 T5	---	Cable entry	2" NPT
HIGH	T1	T2	T3	T4 T7-T5 T8-T6 T9		

Notes:

I_L/I_N = locked rotor current / current nominal
M_L/M_N = locked rotor torque / torque nominal
M_d/M_N = break down torque / nominal torque

3) Value is valid only for DOL operation with motor design IC411
2) at rated power / at full load

responsible dep. DI MC LVM	technical reference	created by DT Configurator	approved by	<i>Technical data are subject to change! There may be discrepancies between software and hardware versions</i>	
	document type datasheet	document status released	customer		
	title 1LE2221-3BA21-6AA3	document number	rev. 01	creation date 2022-04-08 21:14	language en
© Siemens AG 2022				Page 1/1	

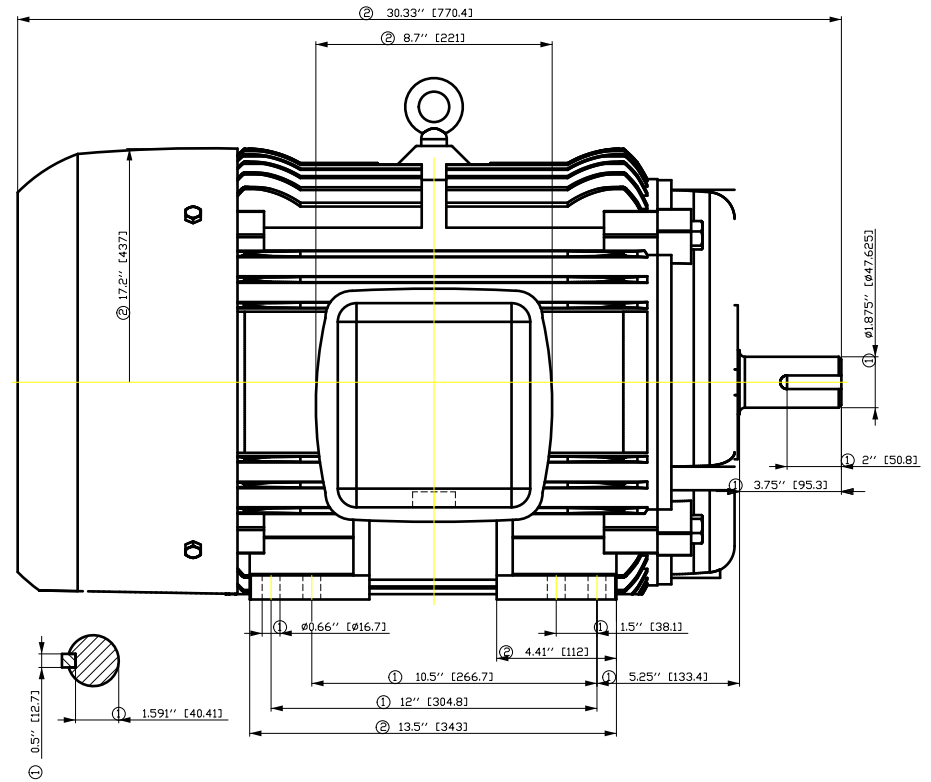
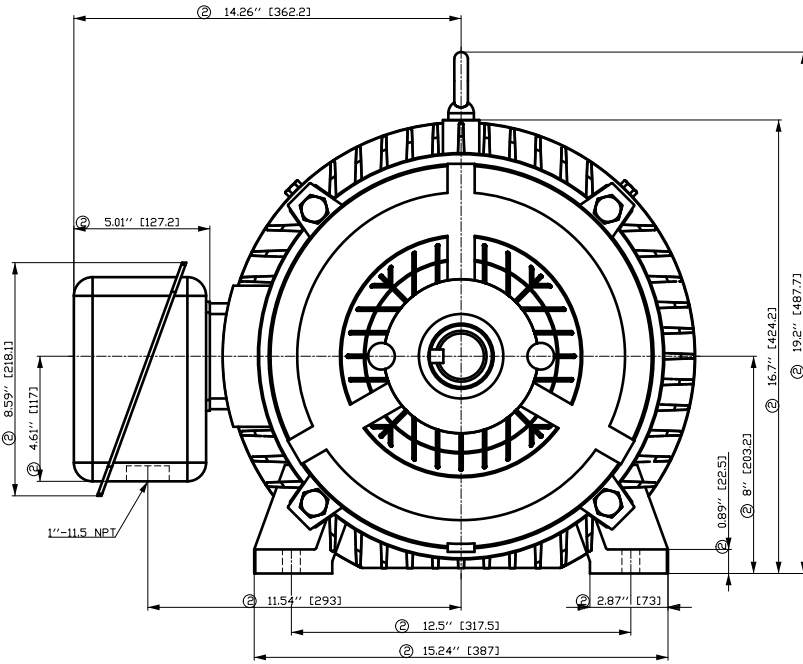

- ① Tolerances according to NEMA std.
- ② All these dimensions corresponding to assemblies and castings shall have a tolerance as per DIN standard 1686-GTB 19.
- ③ Not according to NEMA std.

Tolerance	Surface	Material	Weight	Scale	
F50GGF-H0GGF-E CDEH	Author	ÖS T a : ^ & @ } *	E		
E	Creator				ÖVS
	Approval				
	Department				
	Change Order	MLFB	Doc Type	/	
	Doc. State	I B B G	Item No	Paper Size	
	Revision	Index	RS	1st Language	
				2nd Language	
© Siemens AG	Project No	E	Ref No	E	
2018				Sheet	
				F of F	

SIEMENS INDUSTRY, INC.

HP 50 VOLTS < 600V RPM 3600 TYPE GP100
HZ 60 PHASE 3 FRAME 326TS NEMA B

TORQUE & CURRENT VS. SPEED

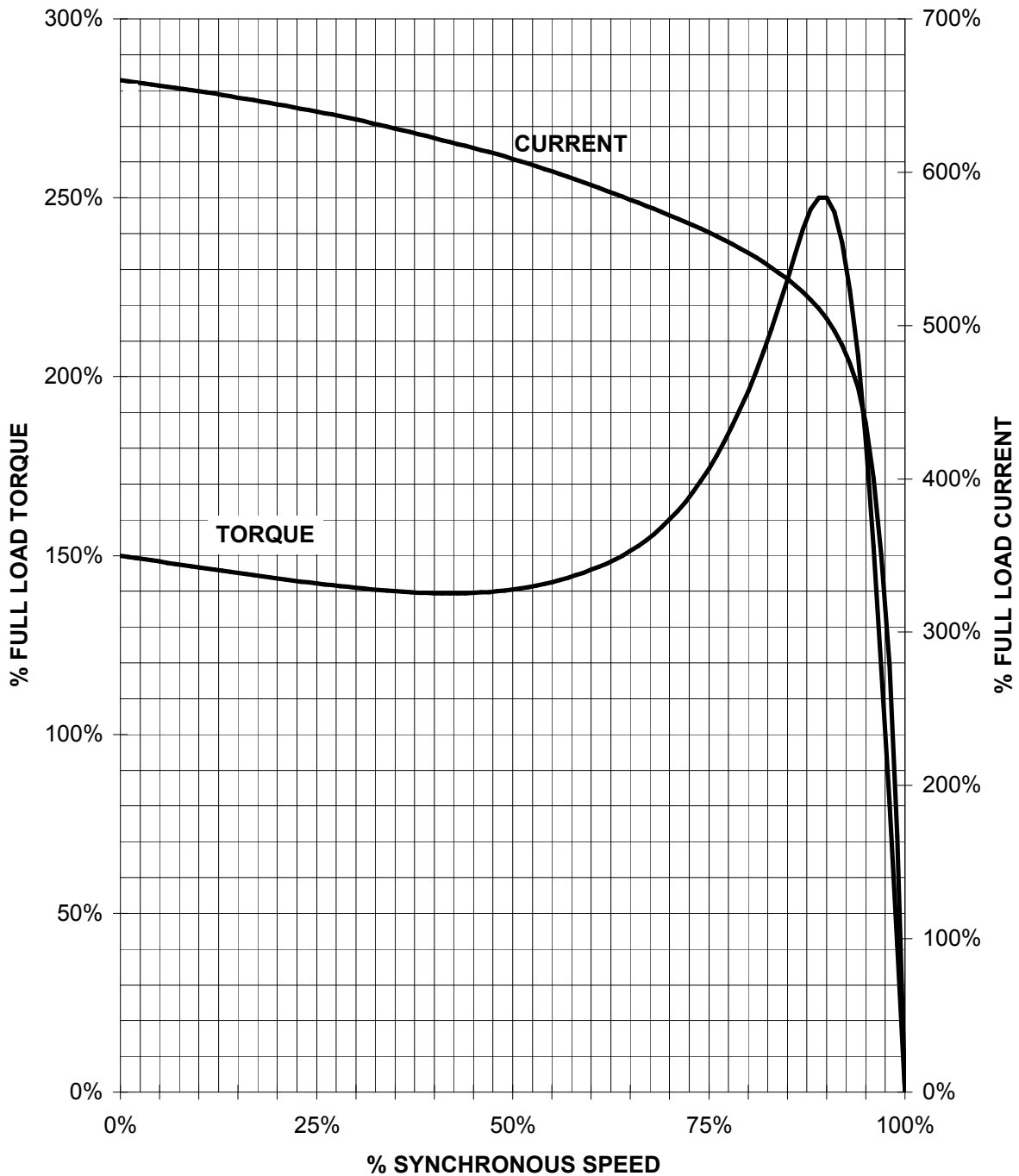

CUSTOMER: _____ ORDER#: _____

50 HP 3600 RPM 326TS FRAME 460 VOLTS 3 PHASE NEMA DESIGN B

SIEMENS INDUSTRY, INC.
PERFORMANCE CURVE
GP100

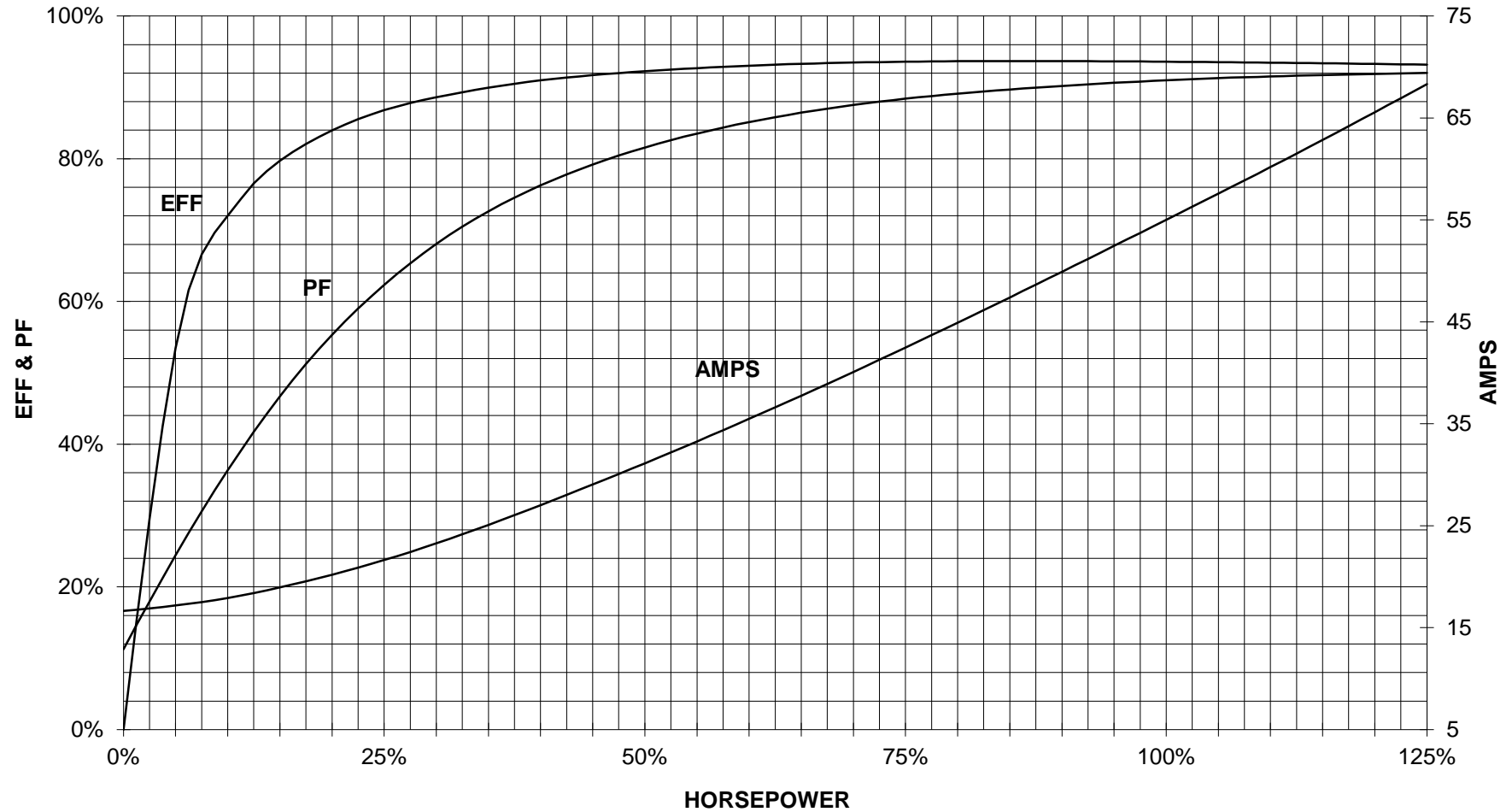

CUSTOMER: _____ ORDER # _____ PO # _____

PERFORMANCE BASED ON DESIGN CALCULATIONS. SUBJECT TO CHANGE WITHOUT NOTICE.

REV. 1

Main terminal diagram

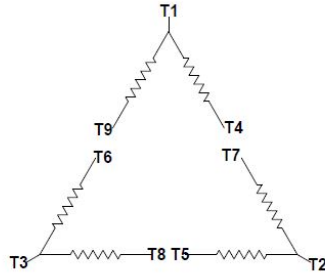

9 LEAD DELTA						
Volts	LINES			CONNECTED TOGETHER	CONN.	
	L1	L2	L3			
LOW	T1 T6	T7 T4	T8 T5	T3 T9		Δ Δ
HIGH	T1	T2	T3	T4 T7-T5 T8-T6 T9		Δ

responsible dep. DI MC LVM	technical reference	created by	approved by	Project
SIEMENS	document type Wiring Diagram	document status free		customer
	title 1LE2221-3BA21-6AA3	document number		
© Siemens AG 2019	rev. 01	creation date 12/03/2019	language en	Page 1/1