

Data sheet for three-phase Squirrel-Cage-Motors SIMOTICS

Motor type: **GP100** FS: **364T - 6p - 40 hp -**

Client order no.	Item-No.	Offer no.
Order no.	Consignment no.	Project
Remarks		

Electrical data

U [V]	Δ / Y	f [Hz]	P [HP]	P [kW]	n [rpm]	I Load [Amps]					LRC	Nom. Eff Load [%]			Pwr. Factor Load [%]			Torque [lb-ft]	T _A /T _N LRT [%]	T _k /T _N BDT [%]
						4/4	3/4	1/2	0	4/4		3/4	2/4	4/4	3/4	2/4				
575	Δ	60	40.00	30.00	1,200	39.20	30.90	23.30	15.20	232.0	94.1	94.6	94.4	81.0	77.0	68.0	177.0	190	220	
Frame Type: 364T		Type of constr.: (A) Foot mounted - End shield				Ins. Cl.: Standard Class F Insulation		Motor Prot.: (A) Without Protection			NEMA Des.: B		S.F.: 1.15							
Mtr. WT: 828						Temp. Rise Cl.: B		Amb. Temp.: + 40 to -20 °C @1000 m			kVA: G		IP 54							

Mechanical data

Sound level (SPL / SWL) at 60 Hz	60.0 dB(A) / 71.0 dB(A)		Thickener	Polyurea					
Octave Band Center Frequencies Hertz			Safe Stall Time Hot	29 s					
	250	500	1000	2000	4000	8000	Hz	Safe Stall Time Cold	55 s
SPL@3	48.0	53.0	54.0	53.0	52.0	50.0	dB(A)	Frame material	cast iron
Moment of inertia	14.8 Lb-ft ²		Color, paint shade	Standard Paint - RAL7030					
Ext Load Inertia Capability:	503.0 Lb ft ²		Coating (paint finish)	Standard Alkyed + Epoxy (C2)					
Bearings			Ventilation Type						
Bearing DE NDE	6314 Z C3 S0		6214 ZZ C3 S0						
Bearing_Type	Ball Bearing		Ball Bearing						
AFBMA:	70BC03JP30		70BC02JPP30						
Grease			Method of cooling						
Capacity	7.5 oz		6.7 oz						
Grease Type:	Exxon Mobile EM		VFD						
			Space heaters						
			Brake:						

Terminal box

Lead Wire Connection		3 LEAD - DELTA			Terminal box position	(3) F-1, Standard Floor Mount, T. Box LHS
Voltage	L1	L1	L1	Connected together	Material of terminal box	Stamped Steel
----	----	----	----	----	Cable entry	3" NPT
----	T1	T2	T3	----		

Notes:

I_L/I_N = locked rotor current / current nominal
M_L/M_N = locked rotor torque / torque nominal
M_B/M_N = break down torque / nominal torque

3) Value is valid only for DOL operation with motor design IC411
2) at rated power / at full load

responsible dep. DI MC LVM	technical reference	created by DT Configurator	approved by	<i>Technical data are subject to change! There may be discrepancies between software and hardware versions</i>	
	document type datasheet	document status released	customer		
	title 1LE2221-3CC11-3AA3	document number			
© Siemens AG 2022	rev. 01	creation date 2022-04-08 21:49	language en	Page 1/1	

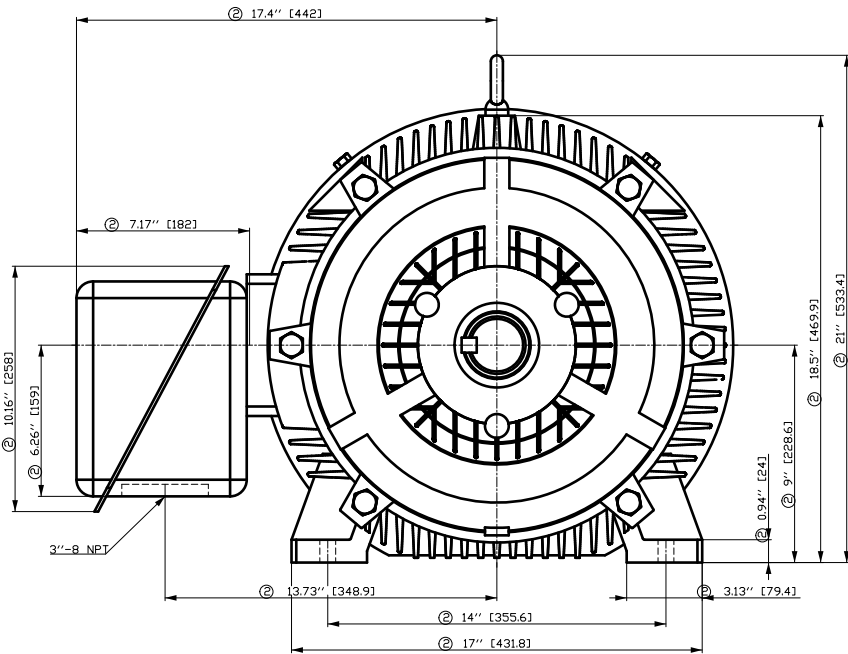

- ① Tolerances according to NEMA std.
- ② All these dimensions corresponding to assemblies and castings shall have a tolerance as per DIN standard 1686-GTB 19.
- ③ Not according to NEMA std.

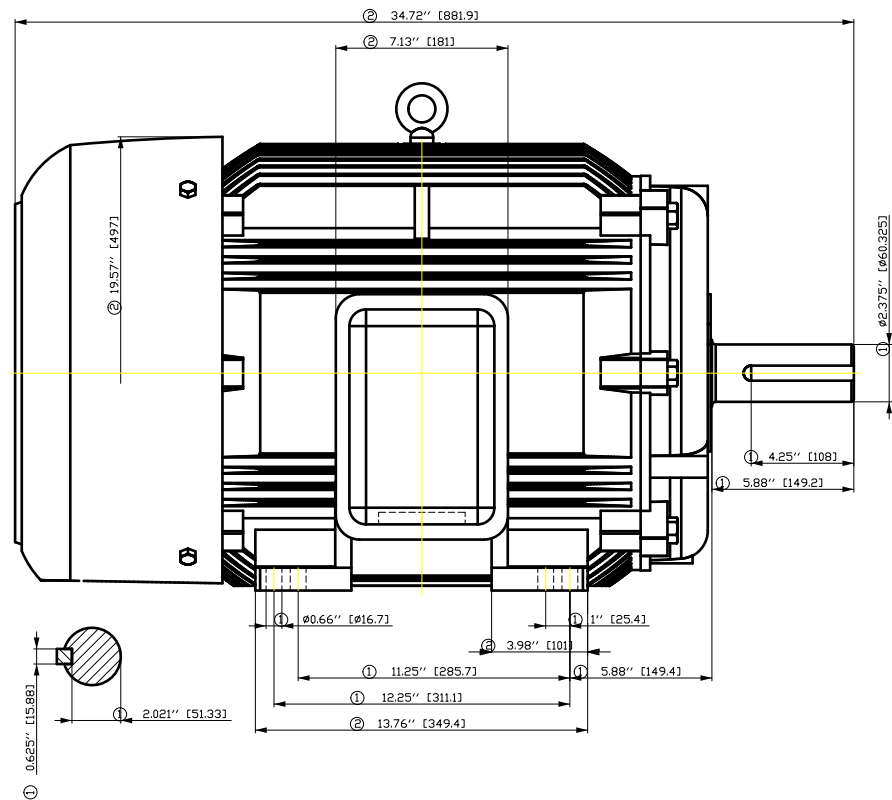

Tolerance	Surface	Material	Weight	Scale
F50GGF#H00FF#00H E	Author Creator Approval Department Change Order	ÖVS T a : ^ & @ } *	E	{ {
SIEMENS	Doc. State	Item No	Doc Type	
	Revision	Index	RS	Paper Size
© Siemens AG	Project No	Ref No	E	F of F

SIEMENS INDUSTRY, INC.

HP 40 VOLTS < 600V RPM 1200 TYPE GP100
HZ 60 PHASE 3 FRAME 364T NEMA B

TORQUE & CURRENT VS. SPEED

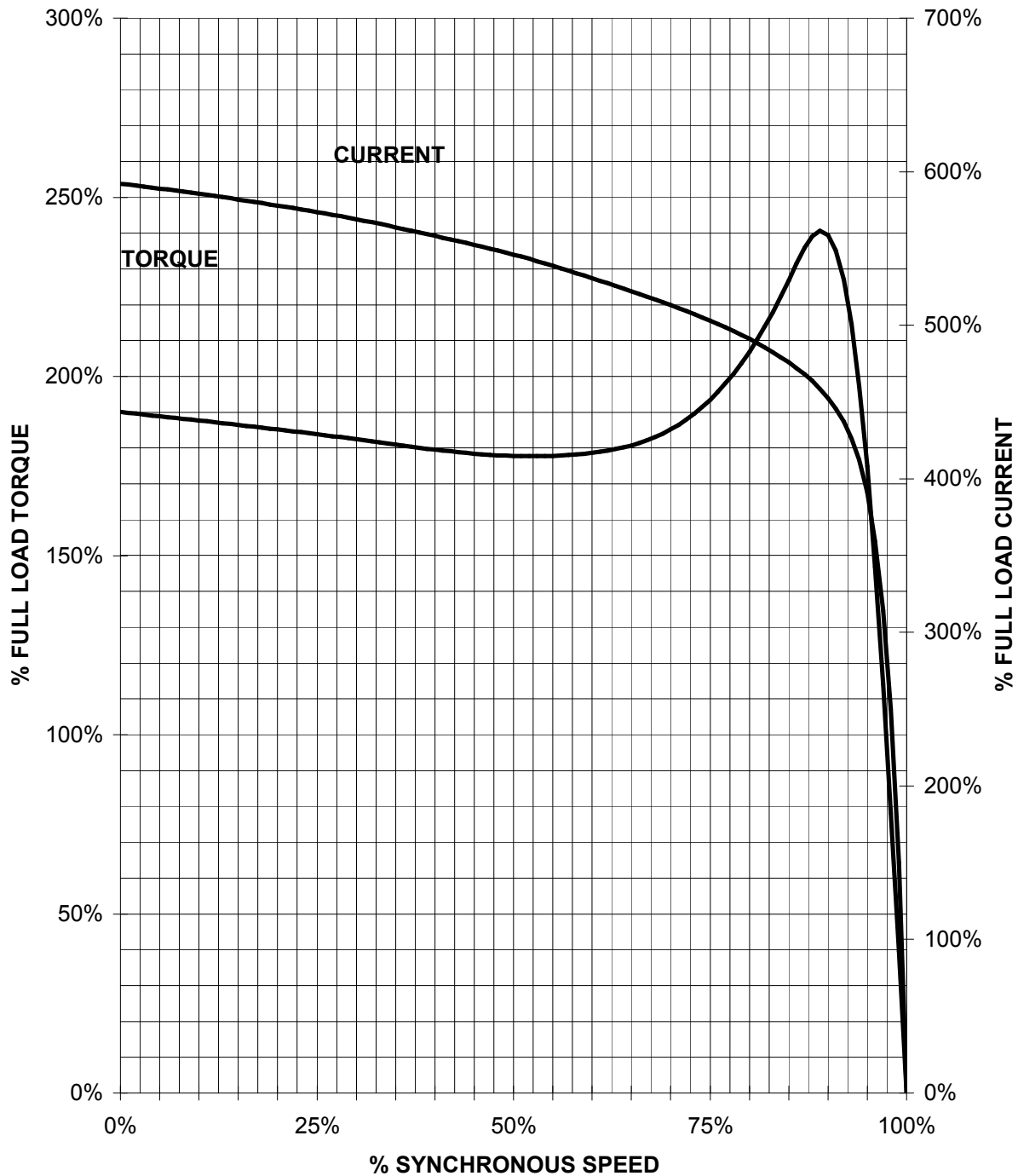

CUSTOMER: _____ ORDER#: _____

40 HP 1200 RPM 365T FRAME 575 VOLTS 3 PHASE NEMA DESIGN B

SIEMENS INDUSTRY, INC.
PERFORMANCE CURVE
GP100

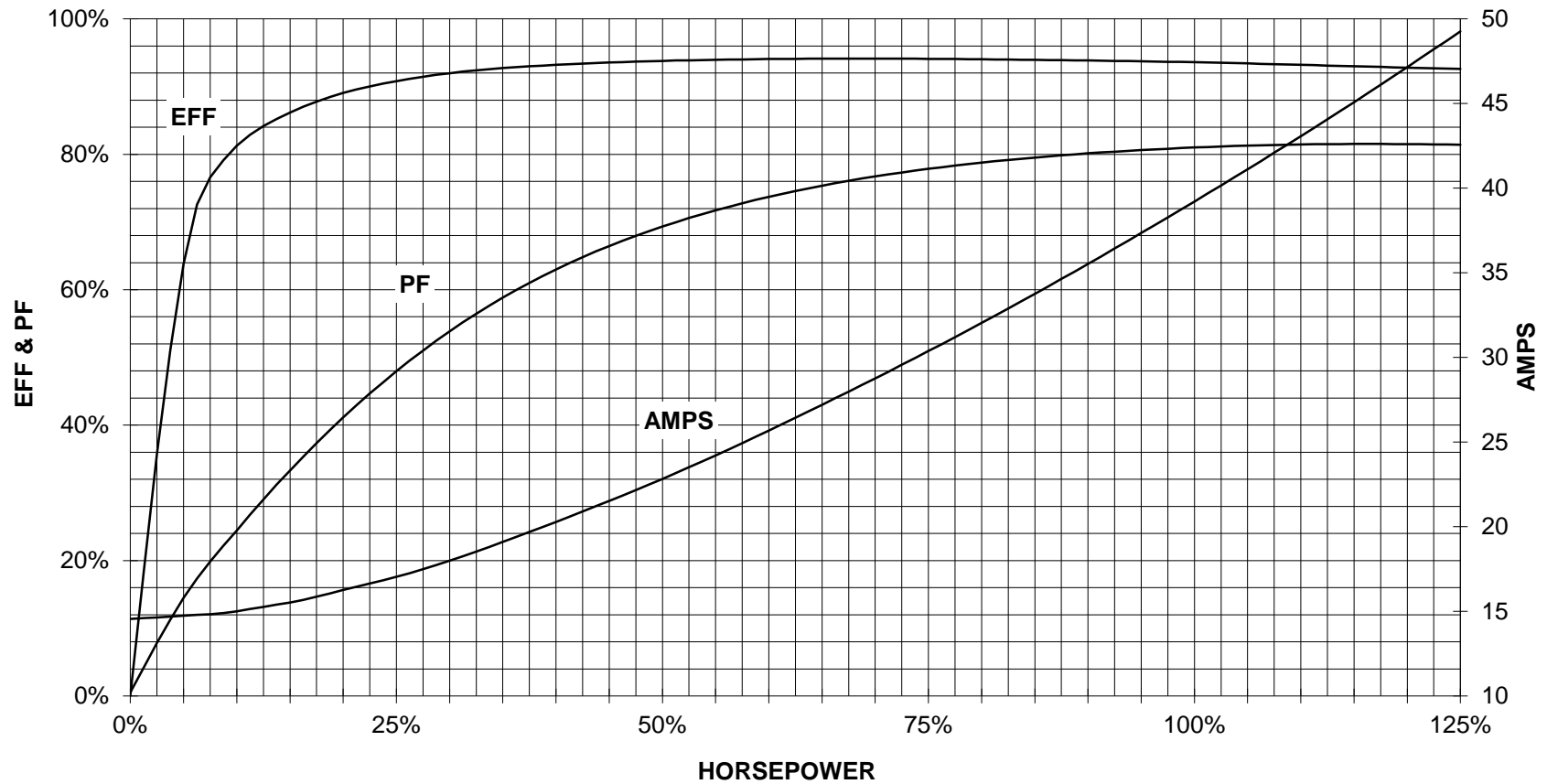

CUSTOMER _____ ORDER # _____ PO # _____

PERFORMANCE BASED ON DESIGN CALCULATIONS. SUBJECT TO CHANGE WITHOUT NOTICE.

REV. 1

Main terminal diagram

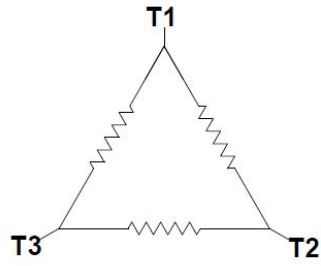

3 LEAD DELTA			
LINES			CONN.
L1	L2	L3	
T1	T2	T3	Δ

responsible dep. DI MC LVM	technical reference	created by	approved by	Project	
	document type Wiring Diagram		document status free		customer
	title 1LE2221-3CC11-3AA3		document number		
© Siemens AG 2019			rev. 01	creation date 12/03/2019	language en
				Page 1/1	