

# Data sheet for three-phase Squirrel-Cage-Motors SIMOTICS

Motor type: **GP100** FS: **365T - 6p - 50 hp -**

Client order no.	Item-No.	Offer no.
Order no.	Consignment no.	Project

Remarks

## Electrical data

U [V]	$\Delta/Y$	f [Hz]	P [HP]	P [kW]	n [rpm]	I Load [Amps]					LRC	Nom. Eff Load [%]			Pwr. Factor Load [%]			Torque [lb-ft]	T <sub>A</sub> /T <sub>N</sub> LRT [%]	T <sub>k</sub> /T <sub>N</sub> BDT [%]
						4/4	3/4	1/2	0	4/4		3/4	2/4	4/4	3/4	2/4				
460	$\Delta$	60	50.00	37.00	1,200	62.00	49.00	37.20	24.00	363.0	94.1	94.3	94.0	80.0	76.0	67.0	222.0	190	220	
230	$\Delta\Delta$	60	50.00	37.00	1,200	124.00	97.99	74.34	48.00	726.0	94.1	94.3	94.0	80.0	76.0	67.0	222.0	190	220	
400	$\Delta$	50	40.00		989	54.70	47.80	38.10	47.00	364.0	92.9	93.3	93.1	82.6	71.4	59.7	288.2	215	248	
200	$\Delta\Delta$	50	40.00		989	109.40	95.60	76.20	94.00	728.0	92.9	93.3	93.1	82.6	71.4	59.7	288.2	215	248	

Frame Type: 365T	Type of constr.: (A) Foot mounted - End shield	Ins. Cl.: Standard Class F Insulation	Motor Prot.: (A) Without Protection	NEMA Des.: B	S.F.: 1.15
Mtr. WT: 863		Temp. Rise Cl.: B	Amb. Temp.: + 40 to -20 °C @1000 m	kVA: G	IP 54

## Mechanical data

Sound level (SPL / SWL) at 60 Hz	60.0 dB(A) / 71.0 dB(A)							Thickener	Polyurea
Octave Band Center Frequencies Hertz								Safe Stall Time Hot	29 s
	250	500	1000	2000	4000	8000	Hz	Safe Stall Time Cold	55 s
SPL@3	48.0	53.0	54.0	53.0	52.0	50.0	dB(A)	Frame material	cast iron
Moment of inertia	16.2 Lb-ft <sup>2</sup>							Color, paint shade	Standard Paint - RAL7030
Ext Load Inertia Capability:	620.0 Lb ft <sup>2</sup>							Coating (paint finish)	Standard Alkyed + Epoxy (C2)
<b>Bearings</b>								<b>Ventilation Type</b>	
Bearing DE   NDE	6314 Z C3 S0			6214 ZZ C3 S0				Method of cooling	TEFC
Bearing_Type	Ball Bearing			Ball Bearing				Direction of rotation	Bidirectional
AFBMA:	70BC03JP30			70BC02JPP30				Fan Material	Polypropylen ESD
<b>Grease</b>								VFD	CT: 4:1 VT: 20:1
Capacity	7.5 oz			6.7 oz				Space heaters	without
Grease Type:	Exxon Mobile EM							Brake:	without

## Terminal box

Lead Wire Connection	9 LEAD - DELTA				Terminal box position	(3) F-1, Standard Floor Mount, T. Box LHS
Voltage	L1	L1	L1	Connected together	Material of terminal box	Stamped Steel
LOW	T1 T7 T6	T2 T8 T4	T3 T9 T5	---	Cable entry	3" NPT
HIGH	T1	T2	T3	T4 T7-T5 T8-T6 T9		

## Notes:

I<sub>L</sub>/I<sub>N</sub> = locked rotor current / current nominal  
M<sub>L</sub>/M<sub>N</sub> = locked rotor torque / torque nominal  
M<sub>d</sub>/M<sub>N</sub> = break down torque / nominal torque

3) Value is valid only for DOL operation with motor design IC411  
2) at rated power / at full load

responsible dep. DI MC LVM	technical reference	created by DT Configurator	approved by	<i>Technical data are subject to change! There may be discrepancies between software and hardware versions</i>	
	document type datasheet	document status released	customer		
	title 1LE2221-3CC21-6AA3	document number	rev. 01	creation date 2022-04-08 21:51	language en
© Siemens AG 2022					Page 1/1

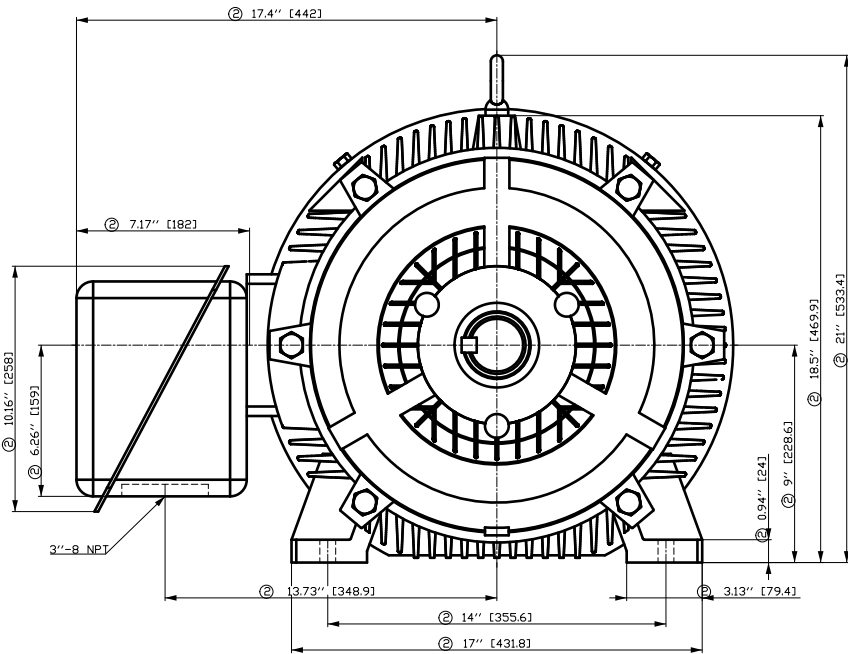

- ① Tolerances according to NEMA std.
- ② All these dimensions corresponding to assemblies and castings shall have a tolerance as per DIN standard 1686-GTB 19.
- ③ Not according to NEMA std.

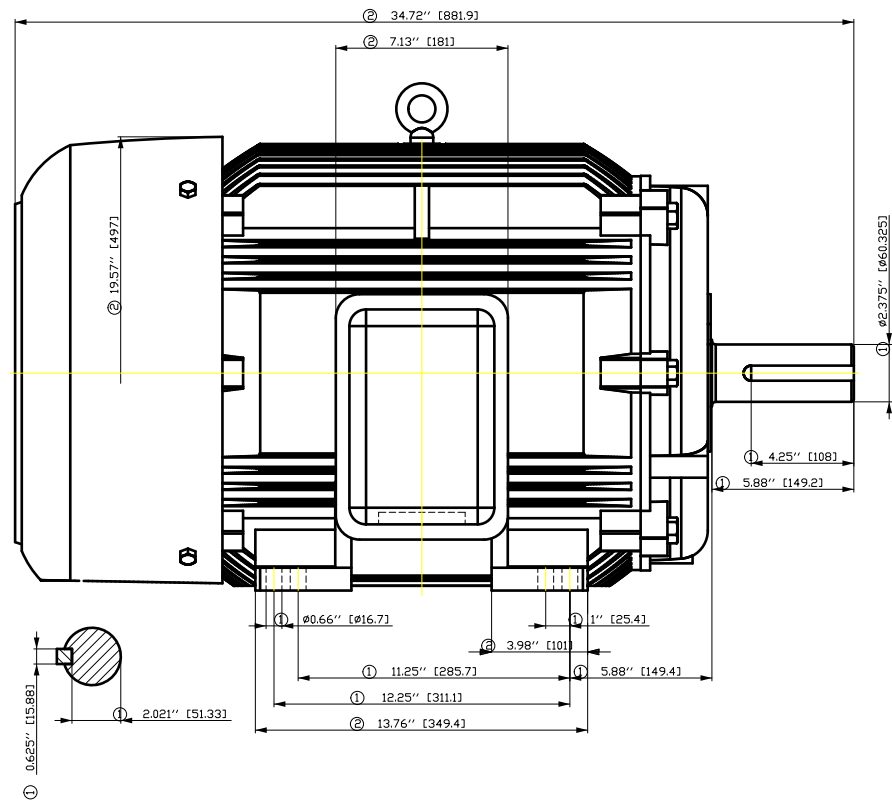

Tolerance	Surface	Material	Weight	Scale
F50CGE#H00GE# EEH E	Author Creator Approval Department Change Order	ÖVS Tæ: ^æ@`)*	E	{ {
SIEMENS	Doc. State	I BGG	Item No	Paper Size CH
	Revision	Index RS	Doc No	1st Language ^) 2nd Language â^
© Siemens AG 2018	Project No E	Ref No E	Doc Type /	Sheet F of F

# SIEMENS INDUSTRY, INC.

HP 50    VOLTS < 600V    RPM 1200    TYPE GP100  
HZ 60    PHASE 3    FRAME 365T    NEMA B

## TORQUE & CURRENT VS. SPEED

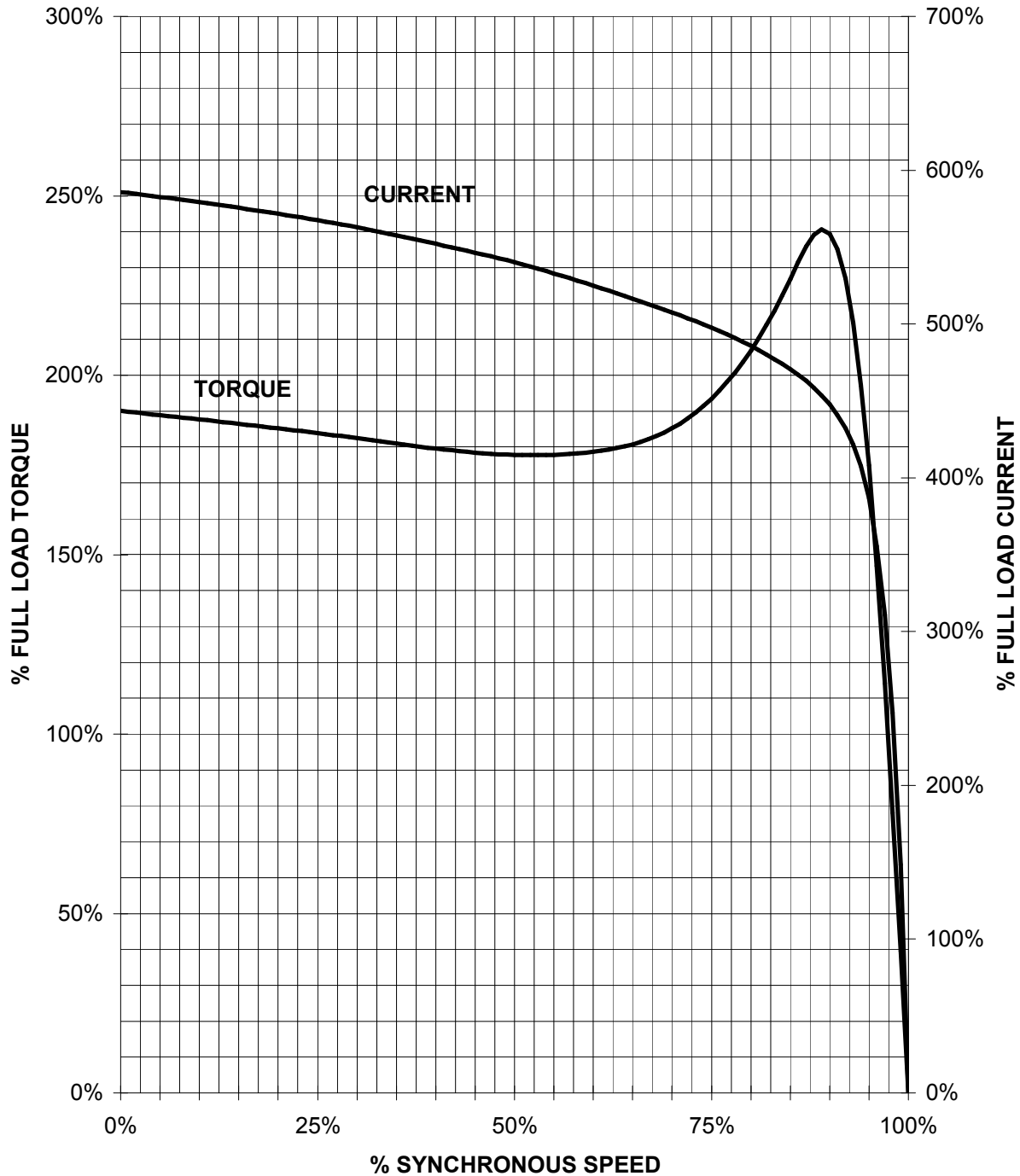

CUSTOMER: \_\_\_\_\_ ORDER#: \_\_\_\_\_

50 HP 1200 RPM 365T FRAME 460 VOLTS 3 PHASE NEMA DESIGN B

**SIEMENS INDUSTRY, INC.**  
**PERFORMANCE CURVE**  
**GP100**

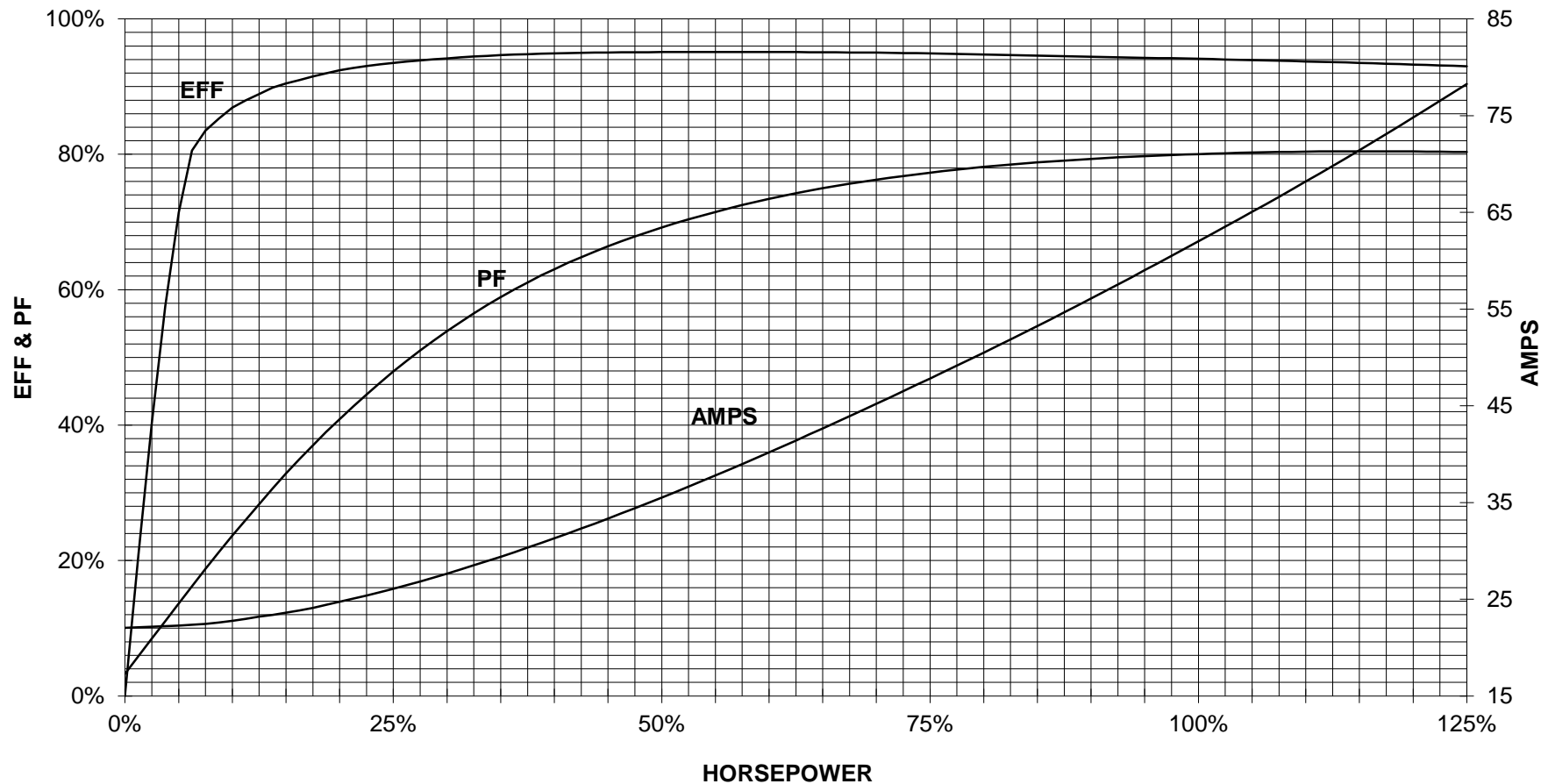

CUSTOMER \_\_\_\_\_ ORDER # \_\_\_\_\_ PO # \_\_\_\_\_

PERFORMANCE BASED ON DESIGN CALCULATIONS. SUBJECT TO CHANGE WITHOUT NOTICE.

REV. 1

Main terminal diagram

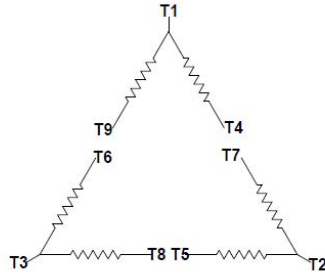

9 LEAD DELTA						
Volts	LINES			CONNECTED TOGETHER	CONN.	
	L1	L2	L3			
LOW	T1 T6	T7 T4	T8 T5	T3 T9		Δ Δ
HIGH	T1	T2	T3	T4 T7-T5 T8-T6 T9		Δ

responsible dep. DI MC LVM	technical reference	created by	approved by	Project
<b>SIEMENS</b>	document type Wiring Diagram	document status free		customer
	title 1LE2221-3CC21-6AA3	document number		
© Siemens AG 2019	rev. 01	creation date 12/03/2019	language en	Page 1/1