

Data sheet for three-phase Squirrel-Cage-Motors SIMOTICS

Motor type: **GP100** FS: **404T - 6p - 60 hp -**

Client order no.	Item-No.	Offer no.
Order no.	Consignment no.	Project
Remarks		

Electrical data

U [V]	Δ / Y	f [Hz]	P [HP]	P [kW]	n [rpm]	I Load [Amps]					LRC	Nom. Eff Load [%]			Pwr. Factor Load [%]			Torque [lb-ft]	T _A /T _N LRT [%]	T _k /T _N BDT [%]
						4/4	3/4	1/2	0	4/4		3/4	2/4	4/4	3/4	2/4				
460	Δ	60	60.00	45.00	1,200	74.00	58.50	45.90	28.00	435.0	94.5	94.7	94.2	80.0	76.0	65.0	266.0	180	220	
230	$\Delta \Delta$	60	60.00	45.00	1,200	148.00	117.09	91.75	56.00	870.0	94.5	94.7	94.2	80.0	76.0	65.0	266.0	180	220	
400	Δ	50	50.00		989	72.70	58.98	47.26	35.00	473.0	93.4	93.6	93.1	77.5	71.6	60.0	360.1	265	256	
200	$\Delta \Delta$	50	50.00		989	145.40	117.96	94.52	70.00	946.0	93.4	93.6	93.1	77.5	71.6	60.0	360.1	265	256	

Frame Type: 404T	Type of constr.: (A) Foot mounted - End shield	Ins. Cl.: Standard Class F Insulation	Motor Prot.: (A) Without Protection	NEMA Des.: B	S.F.: 1.15
Mtr. WT: 1,047		Temp. Rise Cl.: B	Amb. Temp.: + 40 to -20 °C @1000 m	kVA: G	IP 54

Mechanical data

Sound level (SPL / SWL) at 60 Hz	66.0 dB(A) / 77.0 dB(A)		Thickener	Polyurea					
Octave Band Center Frequencies Hertz			Safe Stall Time Hot	25 s					
	250	500	1000	2000	4000	8000	Hz	Safe Stall Time Cold	50 s
SPL@3	58.0	61.0	62.0	57.0	48.0	39.0	dB(A)	Frame material	cast iron
Moment of inertia	21.3 Lb-ft ²		Color, paint shade	Standard Paint - RAL7030					
Ext Load Inertia Capability:	735.0 Lb ft ²		Coating (paint finish)	Standard Alkyed + Epoxy (C2)					
Bearings									
Bearing DE NDE	6316 Z C3 S0		6214 ZZ C3 S0						
Bearing_Type	Ball Bearing		Ball Bearing						
AFBMA:	80BC03JP30		70BC02JPP30						
Grease									
Capacity	7.5 oz		6.7 oz						
Grease Type:	Exxon Mobile EM								
Ventilation Type									
Method of cooling					TEFC				
Direction of rotation					Bidirectional				
Fan Material					Polypropylen ESD				
VFD					CT: 4:1 VT: 20:1				
Space heaters					without				
Brake:					without				

Terminal box

Lead Wire Connection	9 LEAD - DELTA				Terminal box position	(3) F-1, Standard Floor Mount, T. Box LHS
Voltage	L1	L1	L1	Connected together	Material of terminal box	Stamped Steel
LOW	T1 T7 T6	T2 T8 T4	T3 T9 T5	---	Cable entry	3" NPT
HIGH	T1	T2	T3	T4 T7-T5 T8-T6 T9		

Notes:

I_L/I_N = locked rotor current / current nominal
M_L/M_N = locked rotor torque / torque nominal
M_d/M_N = break down torque / nominal torque

3) Value is valid only for DOL operation with motor design IC411
2) at rated power / at full load

responsible dep. DI MC LVM	technical reference	created by DT Configurator	approved by	<i>Technical data are subject to change! There may be discrepancies between our website and our data sheets.</i>	
	document type datasheet	document status released	customer		
	title 1LE2221-4AC11-6AA3	document number	rev. 01	creation date 2022-04-08 22:28	language en
© Siemens AG 2022				Page 1/1	

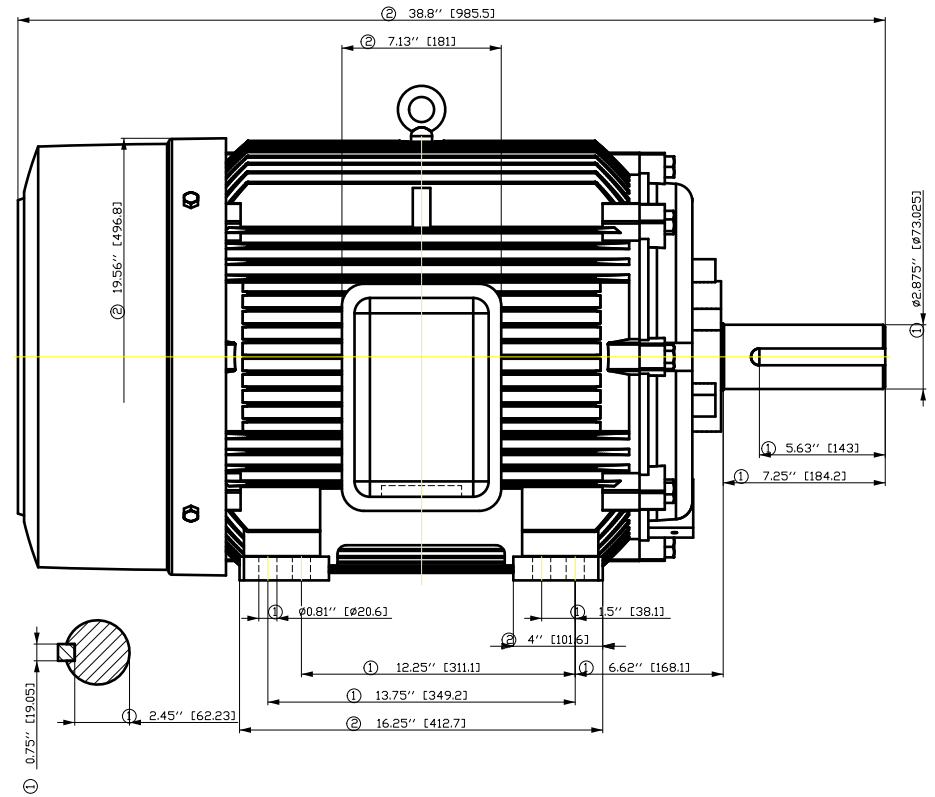
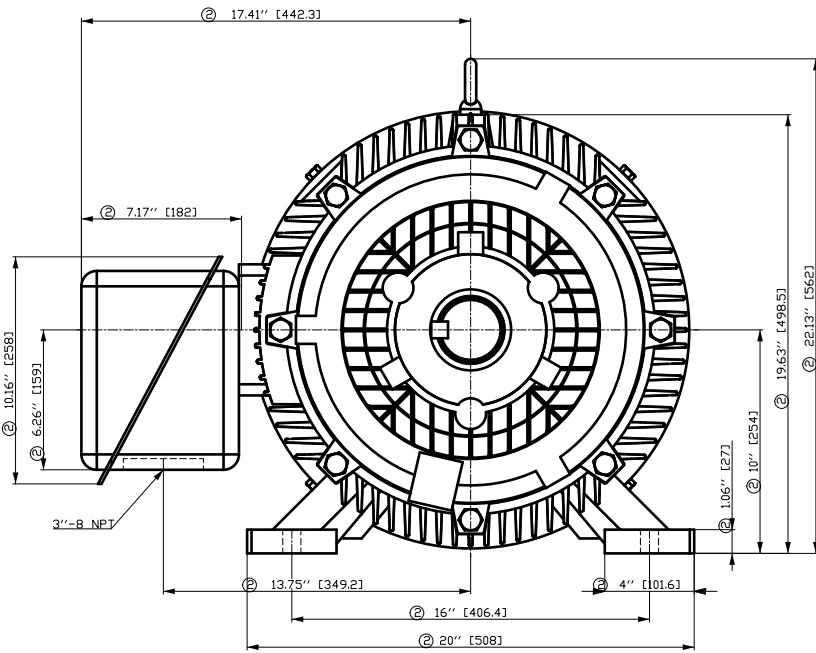

- ① Tolerances according to NEMA std.
- ② All these dimensions corresponding to assemblies and castings shall have a tolerance as per DIN standard 1686-GTB 19.
- ③ Not according to NEMA std.

Tolerance	Surface	Material	Weight	Scale
F50GGGF E	Author Creator Approval Department Change Order	ÖVS T a : ^ @ } *	E	{ {
SIEMENS	Doc. State	Item No	Doc Type	Paper Size
	Revision	Index	Doc No	1st Language
	Project No	RS	Ref No	2nd Language
	© Siemens AG 2018	E	E	F of F

SIEMENS INDUSTRY, INC.

HP 60 VOLTS < 600V RPM 1200 TYPE GP100
HZ 60 PHASE 3 FRAME 404T NEMA B

TORQUE & CURRENT VS. SPEED

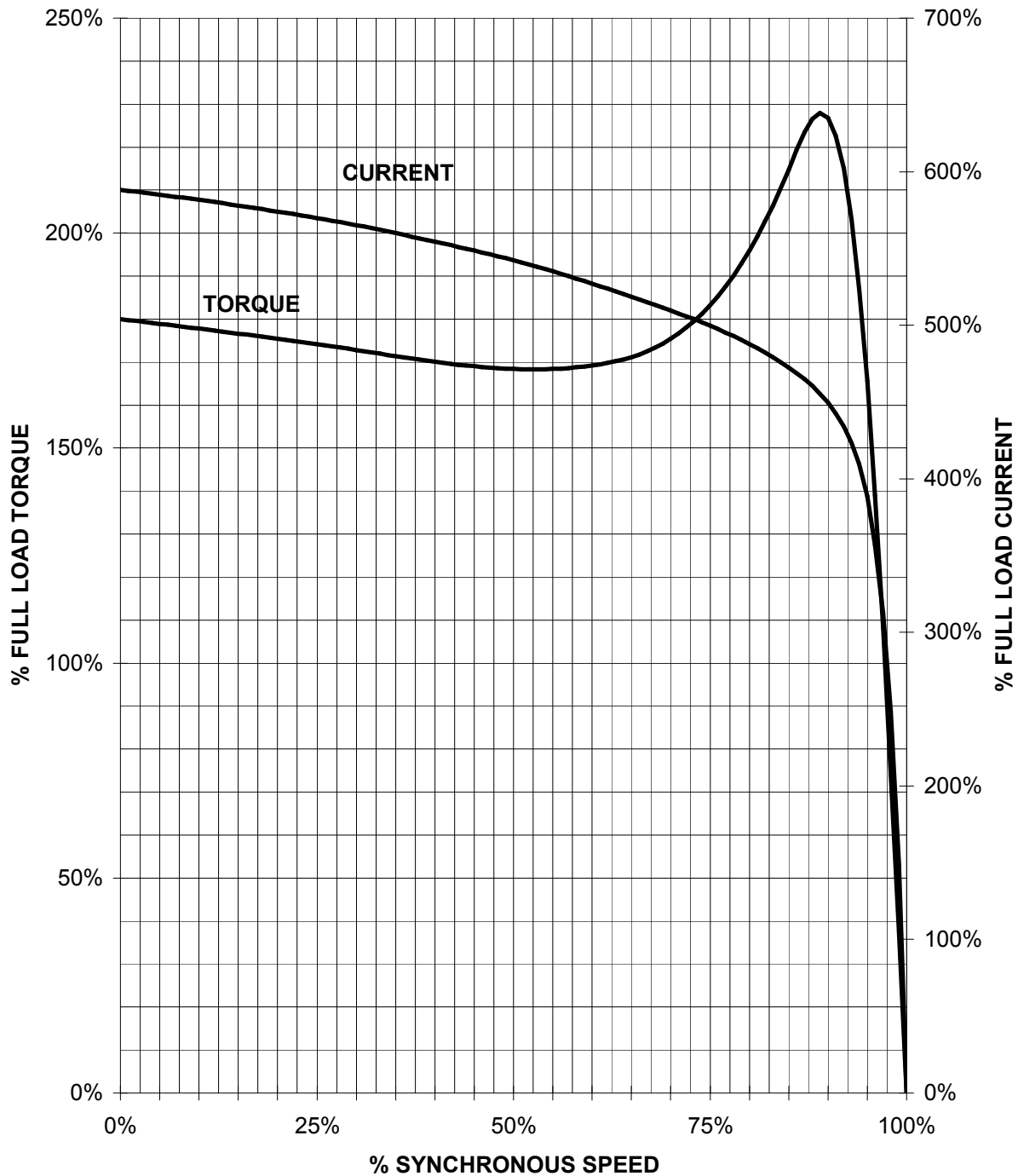

CUSTOMER: _____ ORDER#: _____

60 HP 1200 RPM 404T FRAME 460 VOLTS 3 PHASE NEMA DESIGN B

SIEMENS INDUSTRY, INC.
PERFORMANCE CURVE
GP100

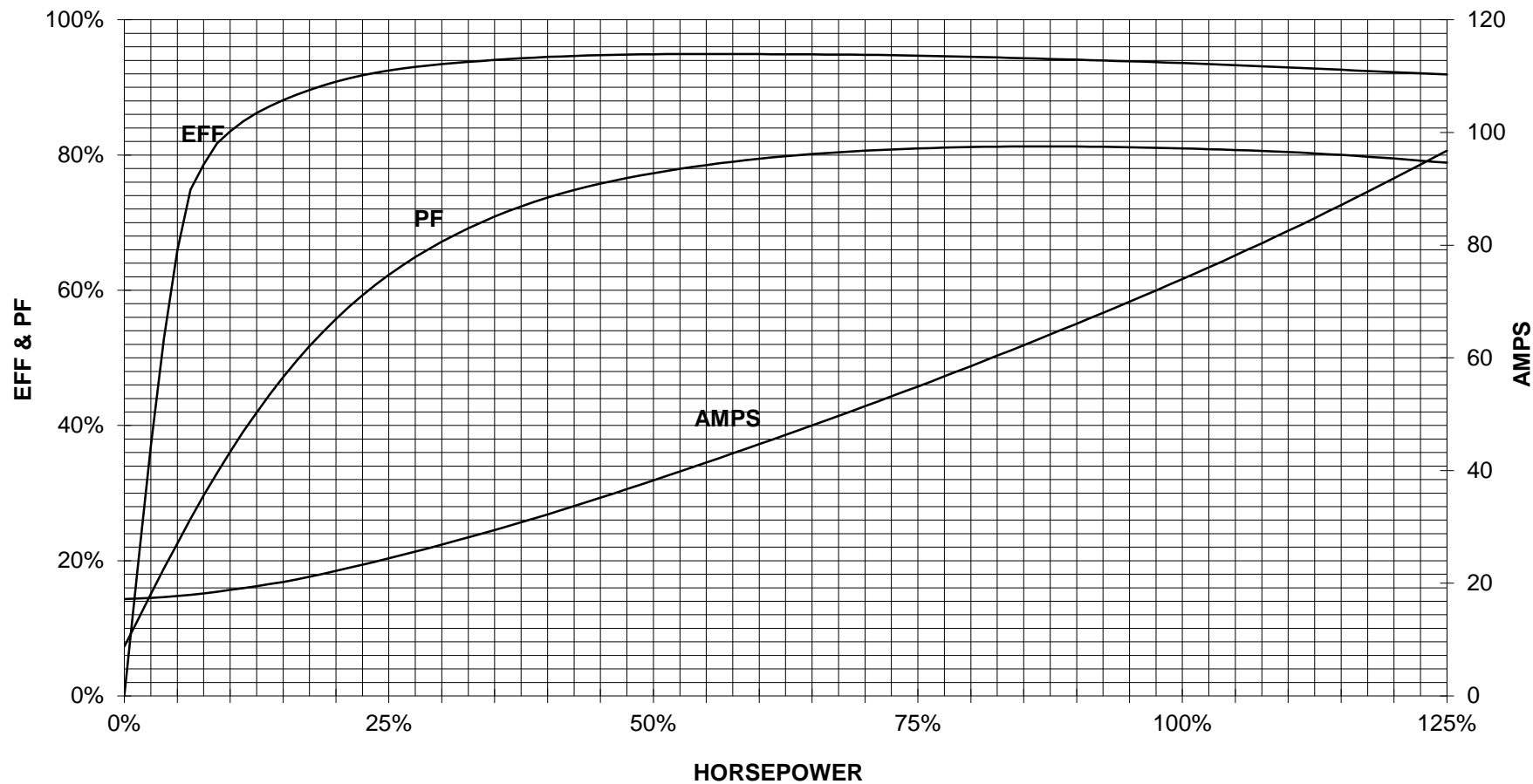

CUSTOMER _____ ORDER # _____ PO # _____

PERFORMANCE BASED ON DESIGN CALCULATIONS. SUBJECT TO CHANGE WITHOUT NOTICE.

REV. 1

Main terminal diagram

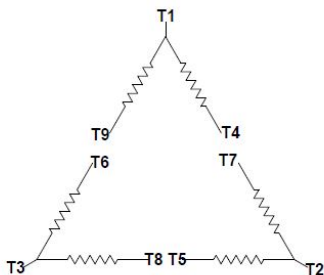

9 LEAD DELTA						
Volts	LINES			CONNECTED TOGETHER	CONN.	
	L1	L2	L3			
LOW	T1 T6	T7 T4	T8 T5	T3 T9		Δ Δ
HIGH	T1	T2	T3	T4 T7-T5 T8-T6 T9		Δ

responsible dep. DI MC LVM	technical reference	created by	approved by	Project			
	document type Wiring Diagram			document status free		customer	
	title 1LE2221-4AC11-6AA3			document number			
© Siemens AG 2019				rev. 01	creation date 12/03/2019	language en	Page 1/1