

Data sheet for three-phase Squirrel-Cage-Motors SIMOTICS

Motor type: **GP100** FS: **449T - 6p - 200 hp -**

Client order no.	Item-No.	Offer no.
Order no.	Consignment no.	Project
Remarks		

Electrical data

U [V]	Δ/Y	f [Hz]	P [HP]	P [kW]	n [rpm]	I Load [Amps]					LRC	Nom. Eff Load [%]			Pwr. Factor Load [%]			Torque [lb-ft]	T _A /T _N LRT [%]	T _k /T _N BDT [%]
						4/4	3/4	1/2	0	4/4		3/4	2/4	4/4	3/4	2/4				
575	Δ	60	200.00	150.00	1,200	181.60	140.70	104.50	58.40	1160.0	95.8	96.2	95.6	86.0	83.0	75.0	883.0	125	201	
Frame Type: 449T		Type of constr.: (A) Foot mounted - End shield					Ins. Cl.: Standard Class F Insulation		Motor Prot.: (A) Without Protection			NEMA Des.: B			S.F.: 1.15					
Mtr. WT: 2,451							Temp. Rise Cl.: B		Amb. Temp.: + 40 to -20 °C @1000 m			kVA: G			IP 54					

Mechanical data

Sound level (SPL / SWL) at 60 Hz	74.0 dB(A) / 86.0 dB(A)							Thickener	Polyurea
Octave Band Center Frequencies Hertz								Safe Stall Time Hot	25 s
	250	500	1000	2000	4000	8000	Hz	Safe Stall Time Cold	32 s
SPL@3	65.0	69.0	70.0	65.0	61.0	52.0	dB(A)	Frame material	cast iron
Moment of inertia	89.7 Lb-ft ²							Color, paint shade	Standard Paint - RAL7030
Ext Load Inertia Capability:	224.0 Lb ft ²							Coating (paint finish)	Standard Alkyed + Epoxy (C2)
Bearings								Ventilation Type	
Bearing DE NDE	NU 320			6316 Z C3 S0				Method of cooling	TEFC
Bearing_Type	Roller Bearing			Ball Bearing				Direction of rotation	Bidirectional
AFBMA:	100RU03M0			80BC03JP30				Fan Material	Polypropylen ESD
Grease								VFD	CT: 4:1 VT: 20:1
Capacity	14.5 oz			7.5 oz				Space heaters	without
Grease Type:	Exxon Mobile EM							Brake:	without

Terminal box

Lead Wire Connection					Terminal box position	(3) F-1, Standard Floor Mount, T. Box LHS
Voltage	L1	L1	L1	Connected together	Material of terminal box	Cast Iron
----	----	----	----	----	Cable entry	3" NPT
----	T1	T2	T3	----		

Notes:

I_L/I_N = locked rotor current / current nominal
M_L/M_N = locked rotor torque / torque nominal
M_B/M_N = break down torque / nominal torque

3) Value is valid only for DOL operation with motor design IC411
2) at rated power / at full load

responsible dep. DI MC LVM	technical reference	created by DT Configurator	approved by	<i>Technical data are subject to change! There may be discrepancies between software and hardware versions</i>			
	document type datasheet	document status released		customer			
	title 1LE2221-4CC51-3AA3	document number					
© Siemens AG 2022	rev. 01	creation date 2022-04-08 22:57	language en	Page 1/1			

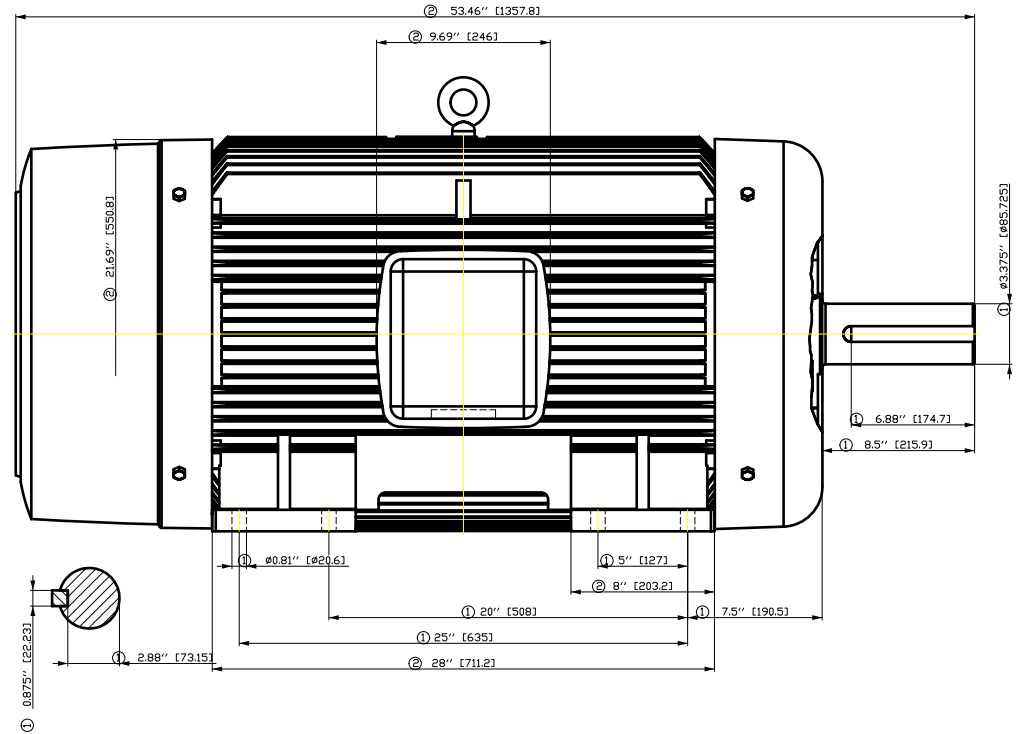
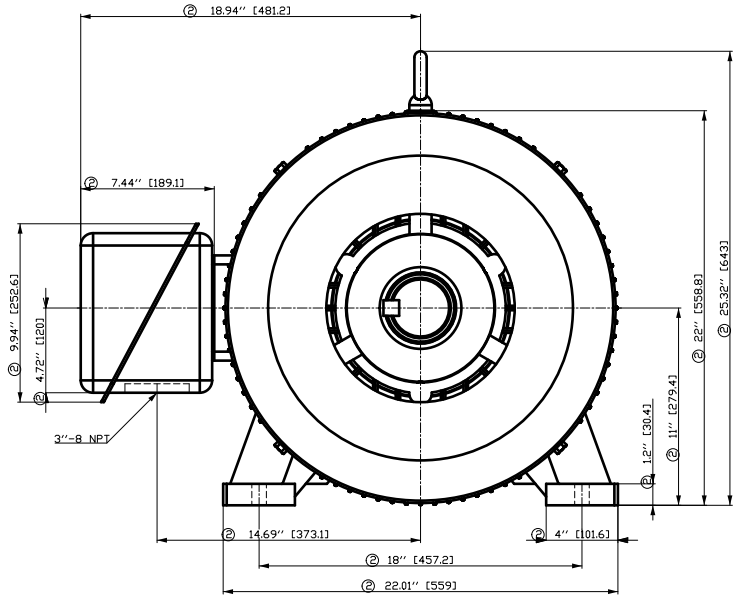

- ① Tolerances according to NEMA std.
- ② All these dimensions corresponding to assemblies and castings shall have a tolerance as per DIN standard 1686-GTB 19.
- ③ Not according to NEMA std.

Tolerance	Surface	Material	Weight	Scale
F50CGGF8 001 F8-00H E	Author Creator Approval Department Change Order	ÖS T a : ^ & @ } *	E	{ {
SIEMENS	Doc. State	Item No	Doc Type	Paper Size
	Revision	Index	Doc No	1st Language
	Project No	E	Ref No	E
© Siemens AG 2018	RS			2nd Language Sheet F of F

SIEMENS INDUSTRY, INC.

HP 200 VOLTS < 600V RPM 1200 TYPE GP100
HZ 60 PHASE 3 FRAME 449T NEMA B

TORQUE & CURRENT VS. SPEED

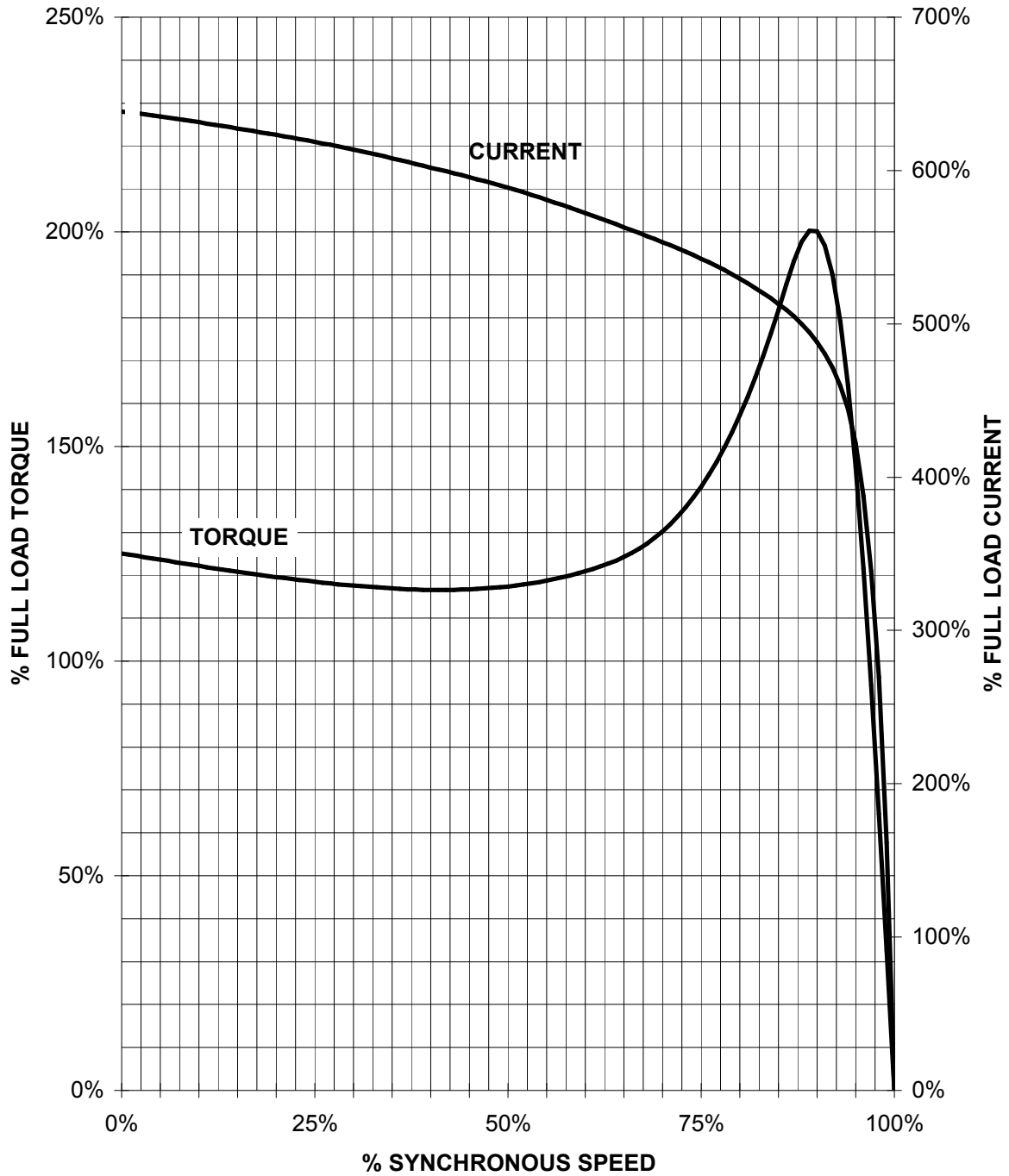

CUSTOMER: _____ ORDER#: _____

200 HP 1200 RPM 449T FRAME 575 VOLTS 3 PHASE NEMA DESIGN B

SIEMENS INDUSTRY, INC.
PERFORMANCE CURVE
GP100

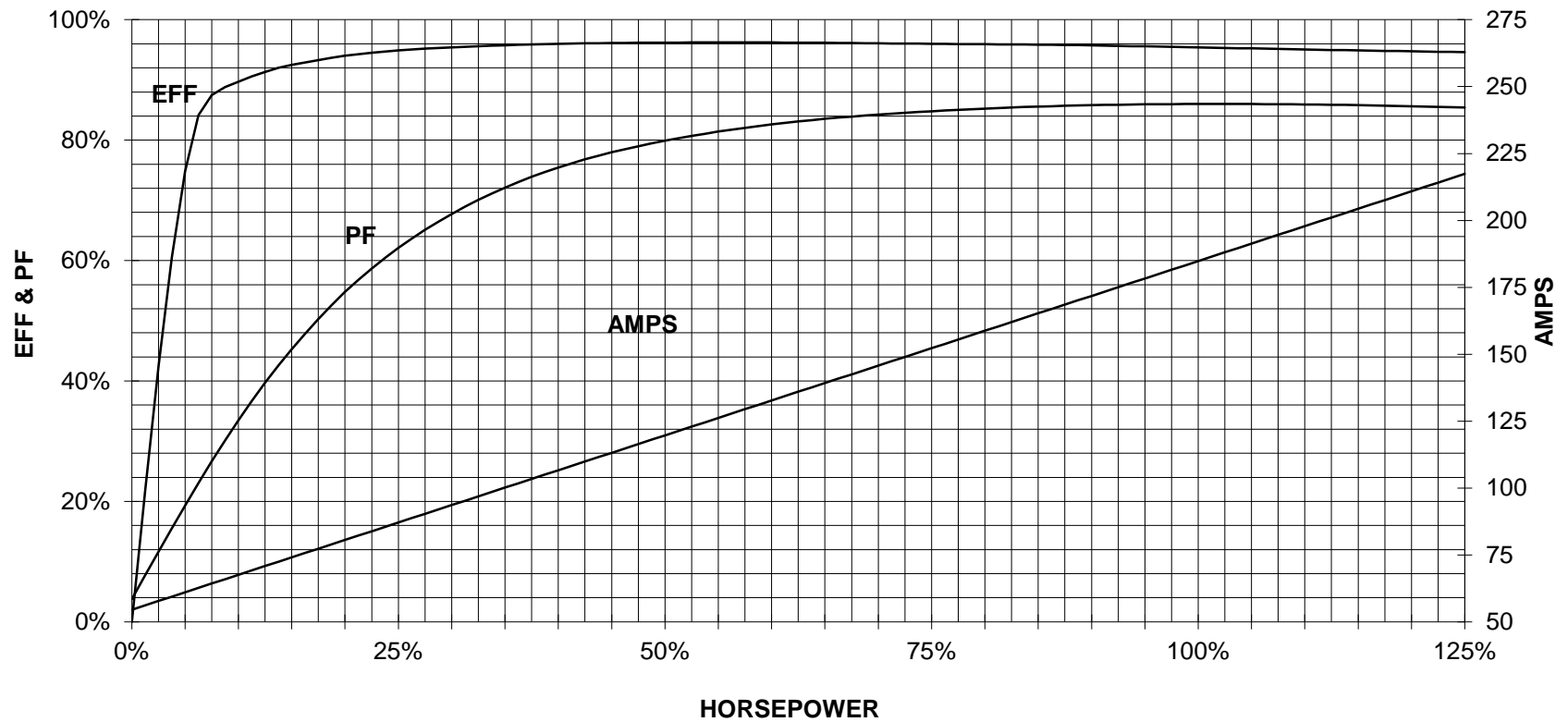

CUSTOMER _____ ORDER # _____ PO # _____

PERFORMANCE BASED ON DESIGN CALCULATIONS. SUBJECT TO CHANGE WITHOUT NOTICE.

REV. 1

Main terminal diagram

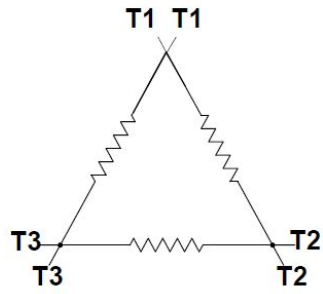

6 LEAD DELTA			
LINES			CONN.
L1	L2	L3	
T1	T2	T3	Δ

responsible dep.
DI MC LVM

technical reference

created by

approved by

Project

SIEMENS

document type
Wiring Diagram

title
1LE2221-4CC51-3AA3

document status
free

document number

customer