

Data sheet for three-phase Squirrel-Cage-Motors SIMOTICS

Motor type: **GP100** FS: 444TS - 4p - 125 hp -

Client order no.	Item-No.	Offer no.
Order no.	Consignment no.	Project

Remarks

Electrical data

U [V]	Δ/Y	f [Hz]	P [HP]	P [kW]	n [rpm]	I Load [Amps]					LRC	Nom. Eff Load [%]			Pwr. Factor Load [%]			Torque [lb-ft]	T _A /T _N LRT [%]	T _k /T _N BDT [%]
						4/4	3/4	1/2	0	4/4		3/4	2/4	4/4	3/4	2/4				
460	Δ	60	125.00	90.00	1,800	115.00	109.30	78.60	45.00	727.0	95.4	95.6	95.4	86.0	84.0	78.0	368.0	160	200	
400	Δ	50	100.00		1,490	134.50	106.10	78.70	53.40	961.0	95.0	95.0	94.5	83.0	78.9	71.3	352.6	207	308	

Frame Type: 444TS	Type of constr.: (A) Foot mounted - End shield	Ins. Cl.: Standard Class F Insulation	Motor Prot.: (A) Without Protection	NEMA Des.: B	S.F.: 1.15
Mtr. WT: 1,527		Temp. Rise Cl.: B	Amb. Temp.: + 40 to -20 °C @ 1000 m	kVA: G	IP 54

Mechanical data

Sound level (SPL / SWL) at 60 Hz	75.0 dB(A) / 86.0 dB(A)							Thickener	Polyurea
Octave Band Center Frequencies Hertz								Safe Stall Time Hot	20 s
	250	500	1000	2000	4000	8000	Hz	Safe Stall Time Cold	25 s
SPL@3	64.0	73.0	68.0	66.0	61.0	51.0	dB(A)	Frame material	cast iron
Moment of inertia	24.3 Lb-ft ²							Color, paint shade	Standard Paint - RAL7030
Ext Load Inertia Capability:	542.0 Lb ft ²							Coating (paint finish)	Standard Alkyed + Epoxy (C2)
Bearings								Ventilation Type	
Bearing DE NDE	6316 Z C3 S0			6216 ZZ C3 S0			Method of cooling	TEFC	
Bearing_Type	Ball Bearing			Ball Bearing			Direction of rotation	Bidirectional	
AFBMA:	80BC03JP30			80BC02JPP30			Fan Material	Polypropylen ESD	
Grease								VFD	CT: 4:1 VT: 20:1
Capacity	7.5 oz			6 oz			Space heaters	without	
Grease Type:	Exxon Mobile EM							Brake:	without

Terminal box

Lead Wire Connection	6 LEAD - DELTA				Terminal box position	(3) F-1, Standard Floor Mount, T. Box LHS	
Voltage	L1	L1	L1	Connected together	Material of terminal box	Cast Iron	
----	----	----	----	----	Cable entry	3" NPT	
----	T1	T2	T3	----			

Notes:

I_L/I_N = locked rotor current / current nominal
M_L/M_N = locked rotor torque / torque nominal
M_d/M_N = break down torque / nominal torque

3) Value is valid only for DOL operation with motor design IC411
2) at rated power / at full load

responsible dep. DI MC LVM	technical reference	created by DT Configurator	approved by	<i>Technical data are subject to change! There may be discrepancies between software and hardware versions</i>			
	document type datasheet	document status released		customer			
	title 1LE2221-4DB11-2AA3	document number					
© Siemens AG 2022	rev. 01	creation date 2022-04-08 23:01	language en	Page 1/1			

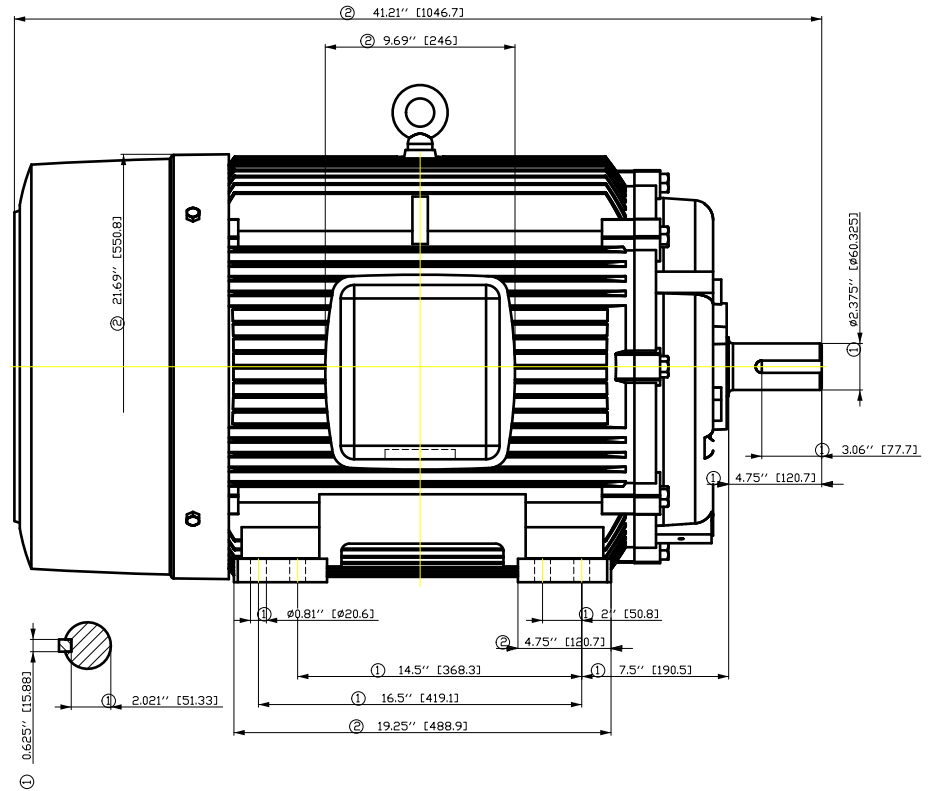
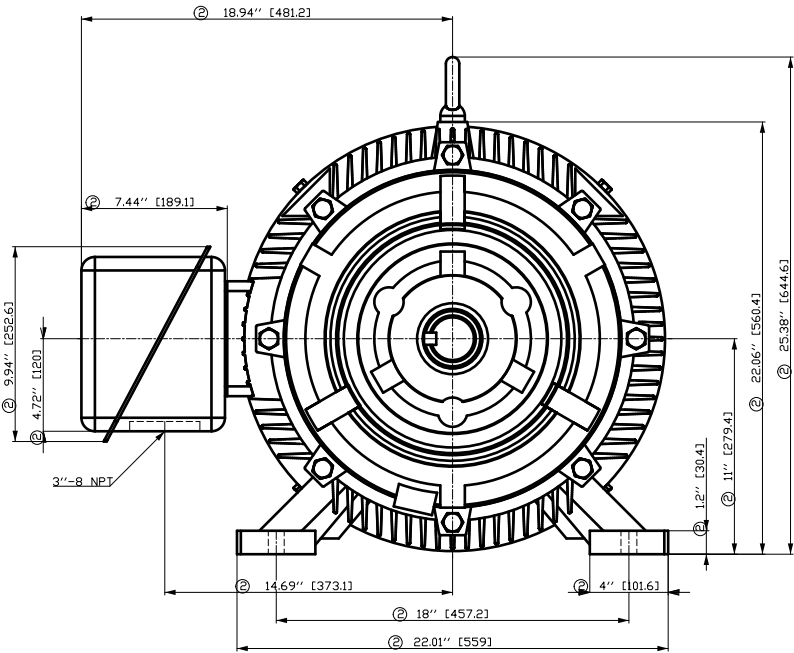

- ① Tolerances according to NEMA std.
- ② All these dimensions corresponding to assemblies and castings shall have a tolerance as per DIN standard 1686-GTB 19.
- ③ Not according to NEMA std.

Tolerance	Surface	Material	Weight	Scale
F50GGGF ÖÖFFB300EH	Author	ÖV	É	{ {
É	Creator	ÖVS		
	Approval	T æ : ^æ@ } *		
	Department			
	Change Order	MLFB		
	Doc. State	I ð BGG		
SIEMENS	Revision	Index RS		
© Siemens AG 2018	Project No	É		
	Item No			
	Doc No			
	Ref No	É		
	Doc Type			
	Paper Size	CH		
	1st Language	^		
	2nd Language	â^		
	Sheet	F of F		

SIEMENS INDUSTRY, INC.

HP 125 VOLTS < 600V RPM 1800 TYPE GP100
HZ 60 PHASE 3 FRAME 444TS NEMA B

TORQUE & CURRENT VS. SPEED

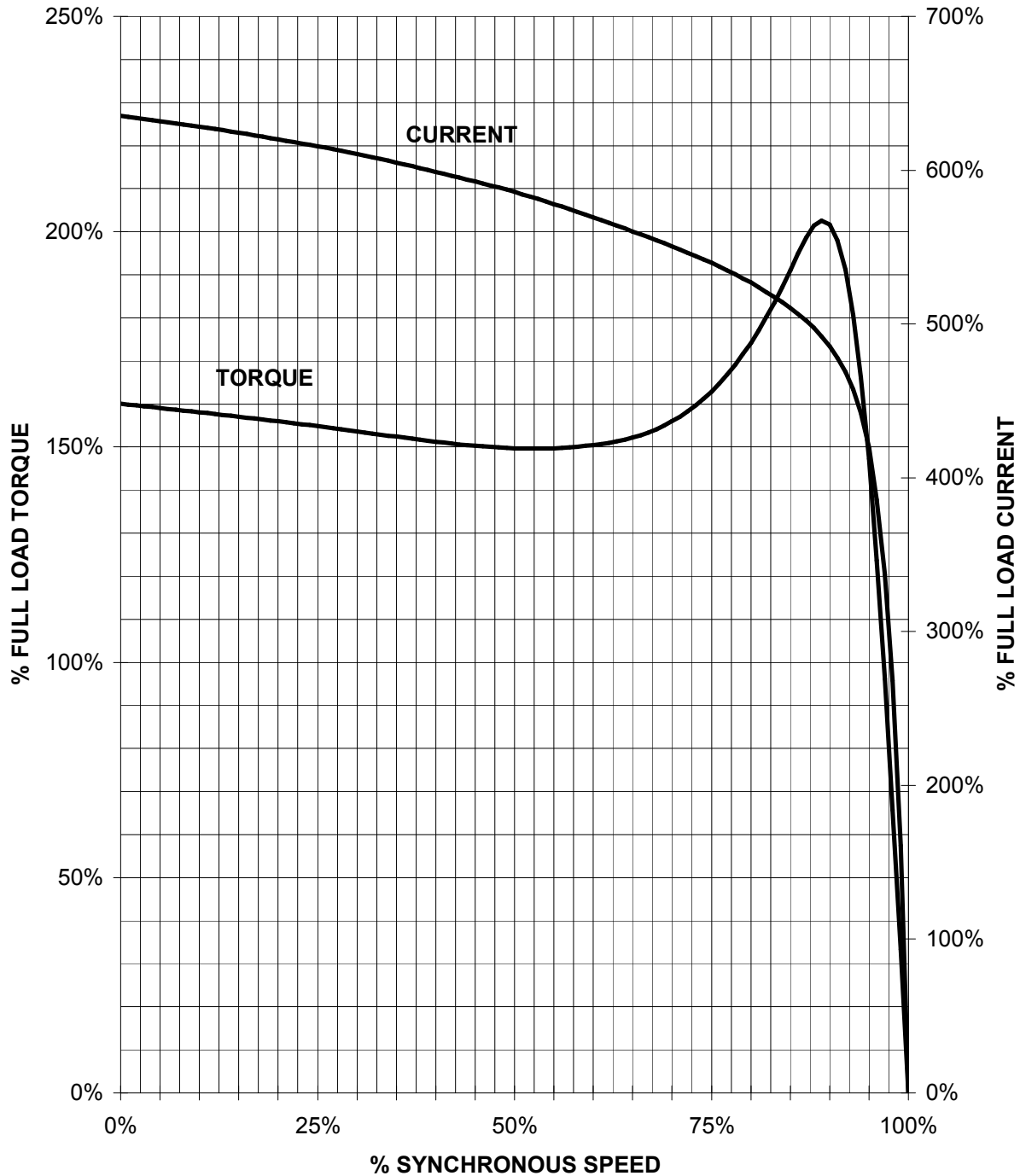

CUSTOMER: _____ ORDER#: _____

125 HP 1800 RPM 444TS FRAME 460 VOLTS 3 PHASE NEMA DESIGN B

SIEMENS INDUSTRY, INC.
PERFORMANCE CURVE
GP100

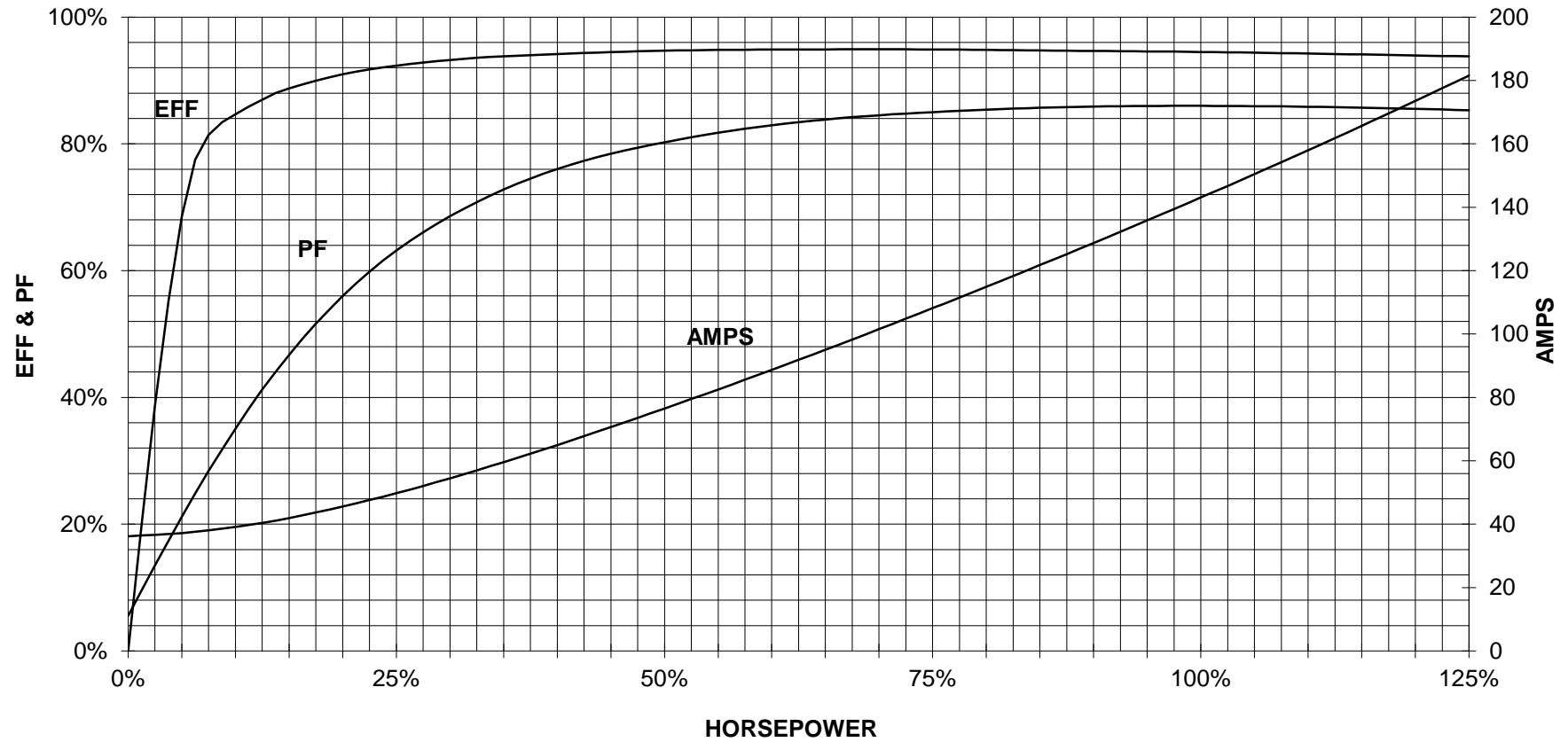

CUSTOMER _____ ORDER # _____ PO # _____

PERFORMANCE BASED ON DESIGN CALCULATIONS. SUBJECT TO CHANGE WITHOUT NOTICE.

REV. 1

Main terminal diagram

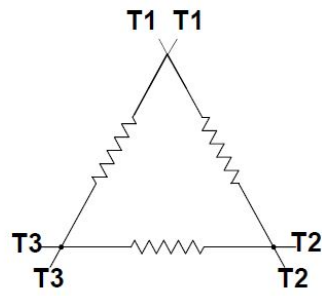

6 LEAD DELTA			
LINES			CONN.
L1	L2	L3	
T1	T2	T3	Δ

responsible dep. DI MC LVM	technical reference	created by	approved by	Project		
	document type Wiring Diagram			document status free		
	title 1LE2221-4DB11-2AA3			document number		
© Siemens AG 2019			rev. 01	creation date 12/03/2019	language en	Page 1/1