

Data sheet for three-phase Squirrel-Cage-Motors SIMOTICS

Motor type: **GP100** FS: 445TS - 4p - 150 hp -

Client order no.	Item-No.	Offer no.
Order no.	Consignment no.	Project
Remarks		

Electrical data

U [V]	Δ / Y	f [Hz]	P [HP]	P [kW]	n [rpm]	I Load [Amps]					Nom. Eff Load [%]			Pwr. Factor Load [%]			Torque [lb-ft]	T _A /T _N LRT [%]	T _k /T _N BDT [%]
						4/4	3/4	1/2	0	LRC	4/4	3/4	2/4	4/4	3/4	2/4	without		
460	Δ	60	150.00	110.00	1,800	170.00	130.60	94.10	52.00	1085.0	95.8	96.0	95.7	86.0	84.0	78.0	441.0	150	200
400	Δ	50	125.00		1,488	164.80	128.20	95.60	57.60	1100.0	95.3	95.4	94.9	85.0	81.9	73.7	441.5	189	258

Frame Type: 445TS	Type of constr.: (A) Foot mounted - End shield	Ins. Cl.: Standard Class F Insulation	Motor Prot.: (A) Without Protection	NEMA Des.: B	S.F.: 1.15
Mtr. WT: 1,680		Temp. Rise Cl.: B	Amb. Temp.: + 40 to -20 °C @1000 m	kVA: G	IP 54

Mechanical data

Sound level (SPL / SWL) at 60 Hz	73.0 dB(A) / 84.0 dB(A)							Thickener	Polyurea	
Octave Band Center Frequencies Hertz								Safe Stall Time Hot	20 s	
	250	500	1000	2000	4000	8000	Hz	Safe Stall Time Cold	30 s	
SPL@3	64.0	70.0	67.0	66.0	59.0	49.0	dB(A)	Frame material	cast iron	
Moment of inertia	44.6 Lb-ft ²							Color, paint shade	Standard Paint - RAL7030	
Ext Load Inertia Capability:	640.0 Lb ft ²							Coating (paint finish)	Standard Alkyed + Epoxy (C2)	
Bearings								Ventilation Type		
Bearing DE NDE	6316 Z C3 S0			6216 ZZ C3 S0			Method of cooling	TEFC		
Bearing_Type	Ball Bearing			Ball Bearing			Direction of rotation	Bidirectional		
AFBMA:	80BC03JP30			80BC02JPP30			Fan Material	Polypropylen ESD		
Grease								VFD	CT: 4:1 VT: 20:1	
Capacity	7.5 oz			6 oz			Space heaters	without		
Grease Type:	Exxon Mobile EM							Brake:	without	

Terminal box

Lead Wire Connection	6 LEAD - DELTA				Terminal box position	(3) F-1, Standard Floor Mount, T. Box LHS	
Voltage	L1	L1	L1	Connected together	Material of terminal box	Cast Iron	
----	----	----	----	----	Cable entry	3" NPT	
----	T1	T2	T3	----			

Notes:

I_L/I_N = locked rotor current / current nominal
M_L/M_N = locked rotor torque / torque nominal
M_d/M_N = break down torque / nominal torque

3) Value is valid only for DOL operation with motor design IC411
2) at rated power / at full load

responsible dep. DI MC LVM	technical reference	created by DT Configurator	approved by	<i>Technical data are subject to change! There may be discrepancies between software and hardware versions</i>			
	document type datasheet	document status released		customer			
	title 1LE2221-4DB21-2AA3	document number					
© Siemens AG 2022	rev. 01	creation date 2022-04-08 23:02	language en	Page 1/1			

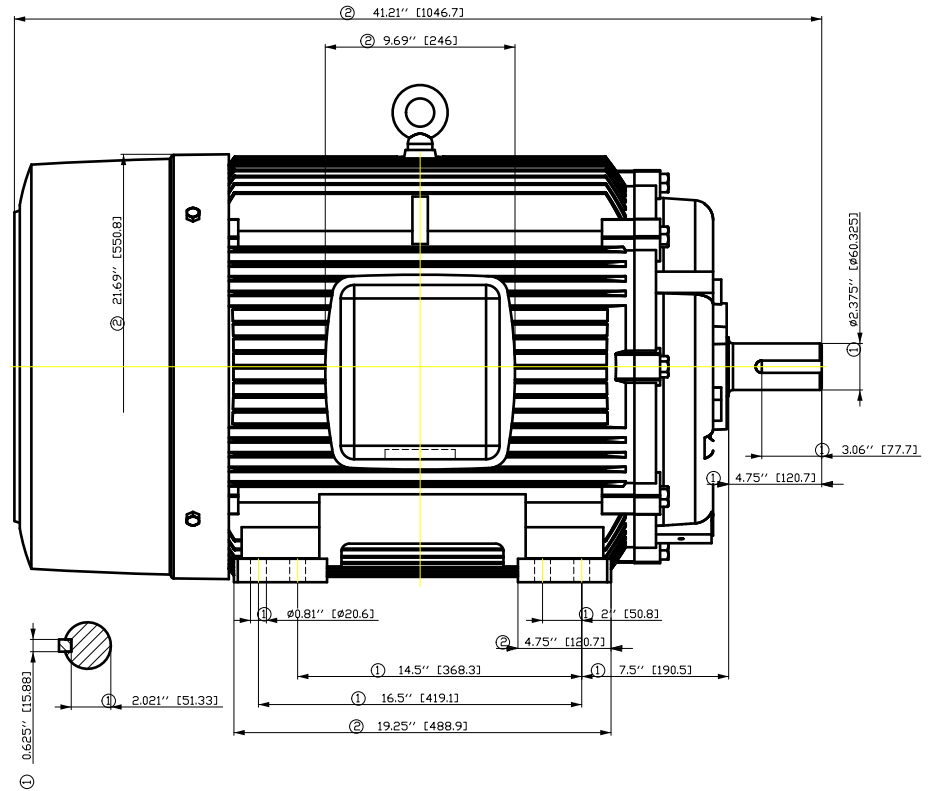
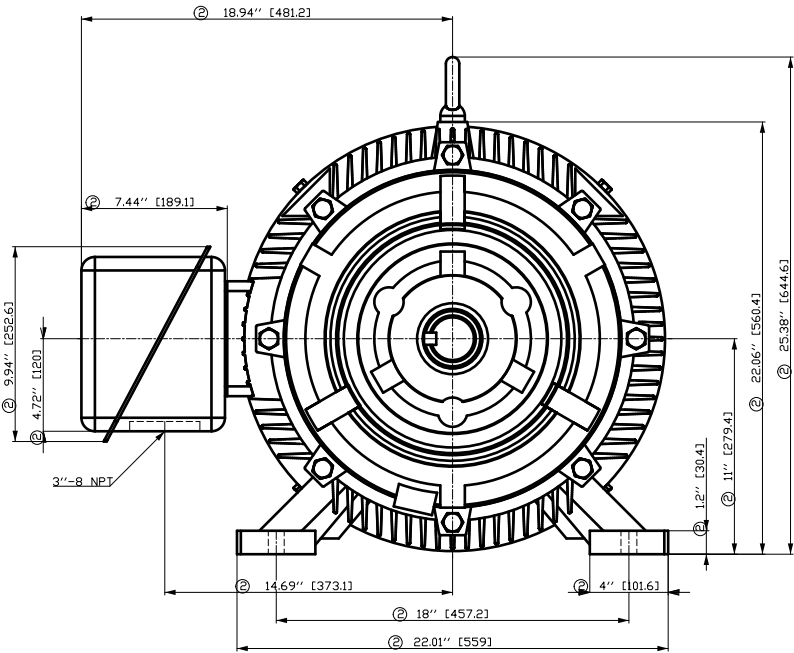

- ① Tolerances according to NEMA std.
- ② All these dimensions corresponding to assemblies and castings shall have a tolerance as per DIN standard 1686-GTB 19.
- ③ Not according to NEMA std.

Tolerance	Surface	Material	Weight	Scale
F50G3F8 ÖÖGF300H E	Author Creator Approval Department Change Order	ÖS Tæ: ^æ@` }*	E	{ {
SIEMENS	Doc. State	Item No	Doc Type	
	Revision	Index	Paper Size	
	© Siemens AG	RS	1st Language	
	2018		2nd Language	
Project No	E	Ref No	E	
			Sheet F of F	

SIEMENS INDUSTRY, INC.

HP 150 VOLTS < 600V RPM 1800 TYPE GP100
HZ 60 PHASE 3 FRAME 445TS NEMA B

TORQUE & CURRENT VS. SPEED

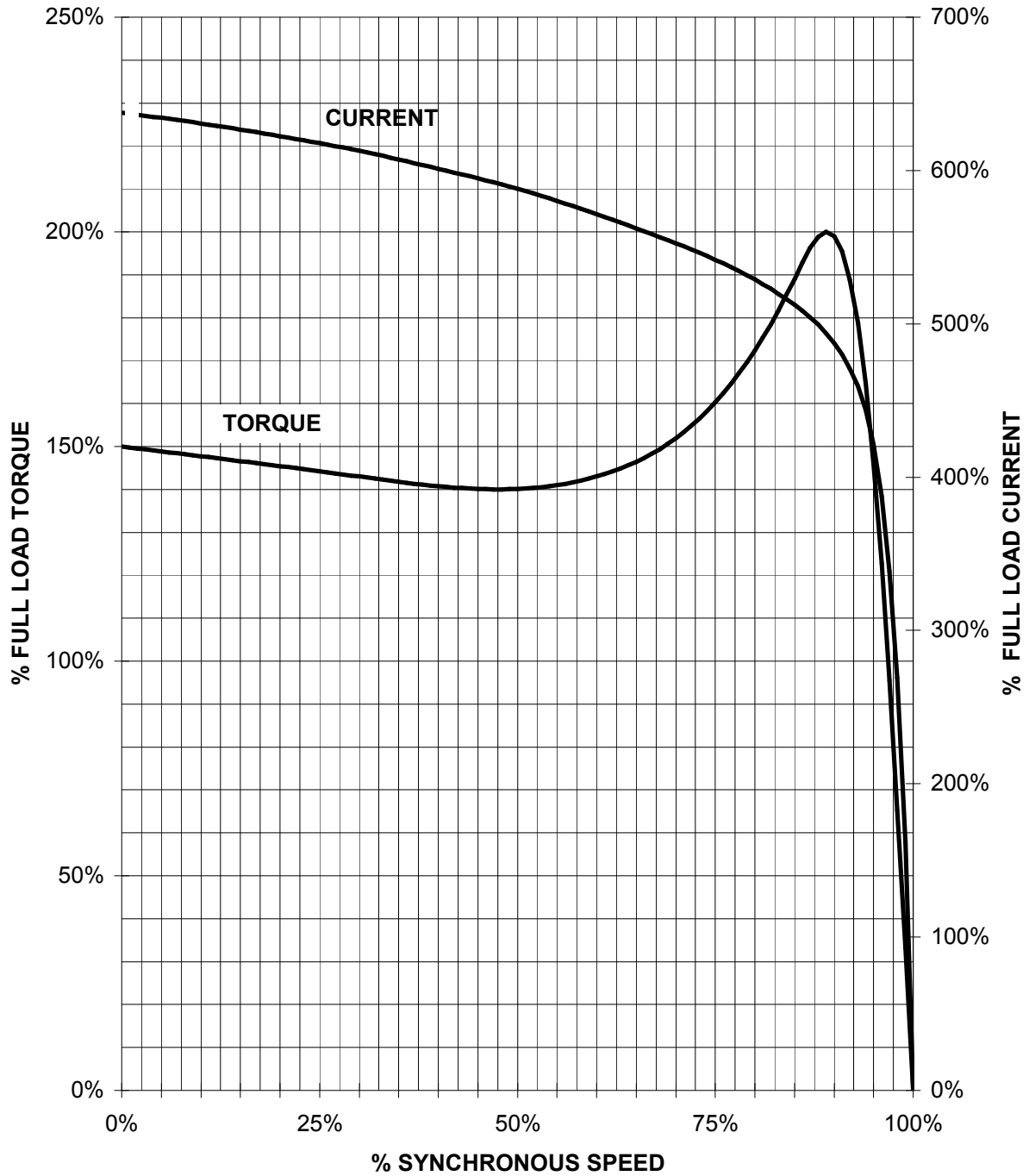

CUSTOMER: _____ ORDER#: _____

150 HP 1800 RPM 445TS FRAME 460 VOLTS 3 PHASE NEMA DESIGN B

SIEMENS INDUSTRY, INC.
PERFORMANCE CURVE
GP100

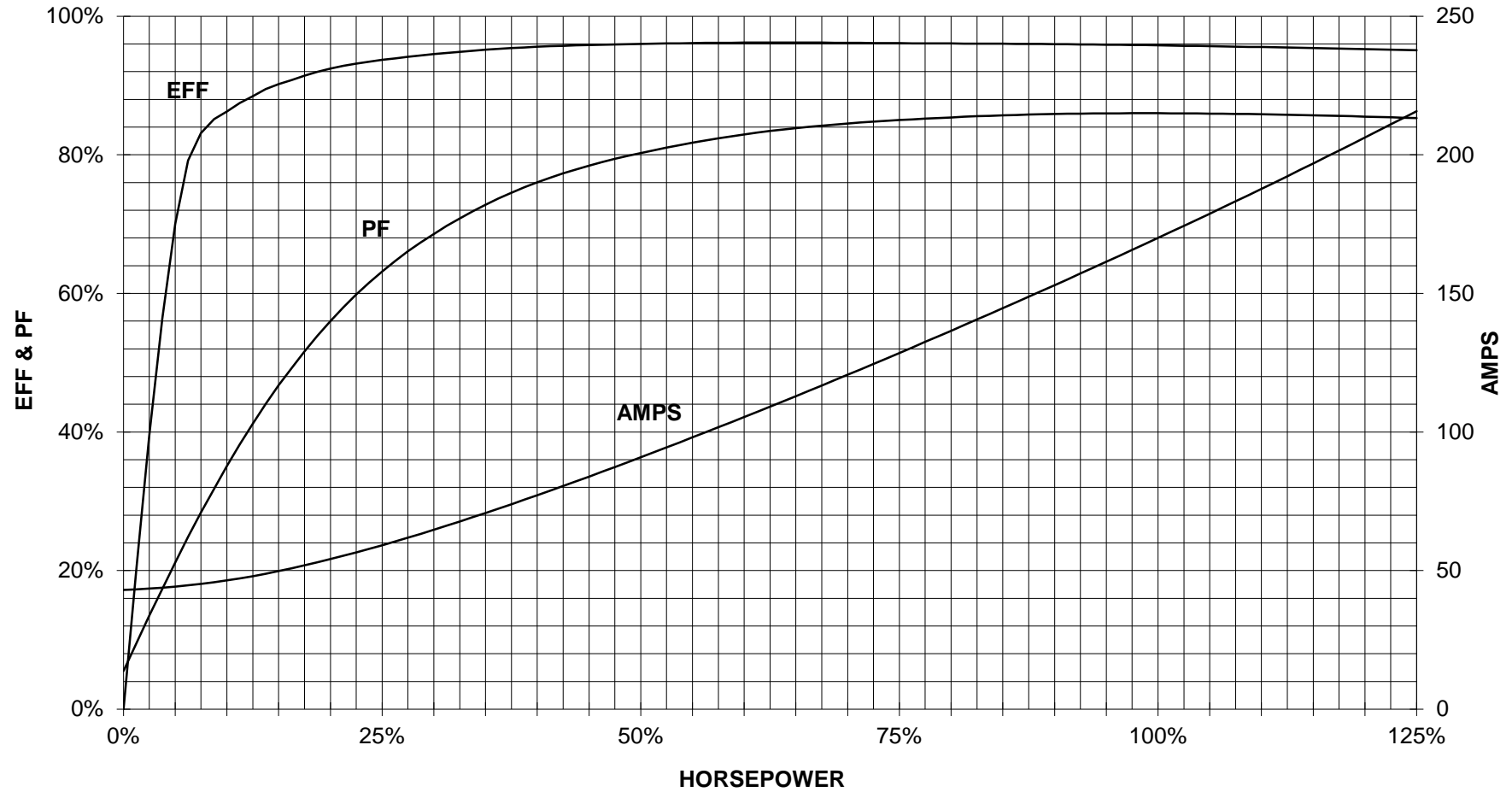

CUSTOMER: _____ ORDER #: _____

PERFORMANCE BASED ON DESIGN CALCULATIONS. SUBJECT TO CHANGE WITHOUT NOTICE.

REV. 1

Main terminal diagram

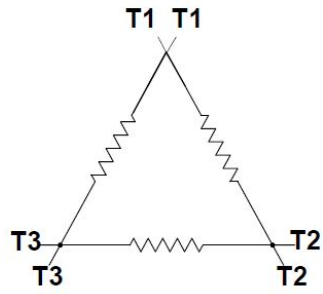

6 LEAD DELTA			
LINES			CONN.
L1	L2	L3	
T1	T2	T3	Δ

responsible dep.
DI MC LVM

technical reference

created by

approved by

Project

SIEMENS

document type
Wiring Diagram

title
1LE2221-4DB21-2AA3

document status
free

document number

customer