

Data sheet for three-phase Squirrel-Cage-Motors SIMOTICS

Motor type: **GP100** FS: 449TS - 6p - 200 hp -

Client order no.	Item-No.	Offer no.
Order no.	Consignment no.	Project

Remarks

Electrical data

without

U [V]	Δ/Y	f [Hz]	P [HP]	P [kW]	n [rpm]	I Load [Amps]					Nom. Eff Load [%]			Pwr. Factor Load [%]			Torque [lb-ft]	T _A /T _N LRT [%]	T _k /T _N BDT [%]
						4/4	3/4	1/2	0	LRC	4/4	3/4	2/4	4/4	3/4	2/4			
460	Δ	60	200.00	150.00	1,200	227.00	175.90	130.60	73.00	1450.0	95.8	96.2	95.6	86.0	83.0	75.0	883.0	125	201
400	Δ	50	150.00		991	210.60	169.60	135.00	96.90	1471.8	95.2	95.4	95.0	80.0	74.4	62.6	794.5	223	344

Frame Type: 449TS	Type of constr.: (A) Foot mounted - End shield	Ins. Cl.: Standard Class F Insulation	Motor Prot.: (A) Without Protection	NEMA Des.: B	S.F.: 1.15
Mtr. WT: 2,400		Temp. Rise Cl.: B	Amb. Temp.: + 40 to -20 °C @1000 m	kVA: G	IP 54

Mechanical data

Sound level (SPL / SWL) at 60 Hz	74.0 dB(A) / 86.0 dB(A)							Thickener	Polyurea
Octave Band Center Frequencies Hertz								Safe Stall Time Hot	25 s
	250	500	1000	2000	4000	8000	Hz	Safe Stall Time Cold	32 s
SPL@3	65.0	69.0	70.0	65.0	61.0	52.0	dB(A)	Frame material	cast iron
Moment of inertia	89.2 Lb-ft ²							Color, paint shade	Standard Paint - RAL7030
Ext Load Inertia Capability:	224.0 Lb ft ²							Coating (paint finish)	Standard Alkyed + Epoxy (C2)
Bearings								Ventilation Type	
Bearing DE NDE	6316 Z C3 S0			6216 ZZ C3 S0			Method of cooling	TEFC	
Bearing_Type	Ball Bearing			Ball Bearing			Direction of rotation	Bidirectional	
AFBMA:	80BC03JP30			80BC02JPP30			Fan Material	Polypropylen ESD	
Grease								VFD	CT: 4:1 VT: 20:1
Capacity	7.5 oz			6 oz			Space heaters	without	
Grease Type:	Exxon Mobile EM							Brake:	without

Terminal box

Lead Wire Connection				6 LEAD - DELTA				Terminal box position	(3) F-1, Standard Floor Mount, T. Box LHS	
Voltage	L1	L1	L1	Connected together				Material of terminal box	Cast Iron	
----	----	----	----	----				Cable entry	3" NPT	
----	T1	T2	T3	----						

Notes:

I_L/I_N = locked rotor current / current nominal
M_L/M_N = locked rotor torque / torque nominal
M_d/M_N = break down torque / nominal torque

3) Value is valid only for DOL operation with motor design IC411
2) at rated power / at full load

responsible dep. DI MC LVM	technical reference	created by DT Configurator	approved by	<i>Technical data are subject to change! There may be discrepancies between software and hardware versions</i>
-------------------------------	---------------------	-------------------------------	-------------	--

	document type datasheet	document status released	customer	
	title 1LE2221-4DC51-2AA3	document number		
© Siemens AG 2022	rev. 01	creation date 2022-04-08 23:06	language en	Page 1/1

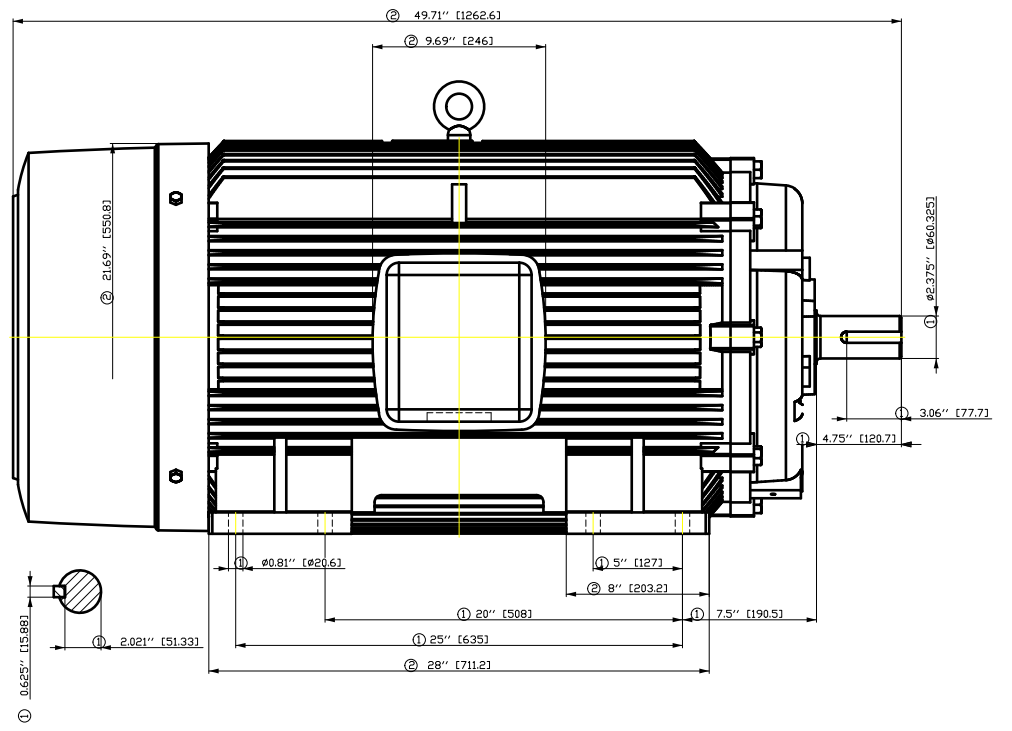
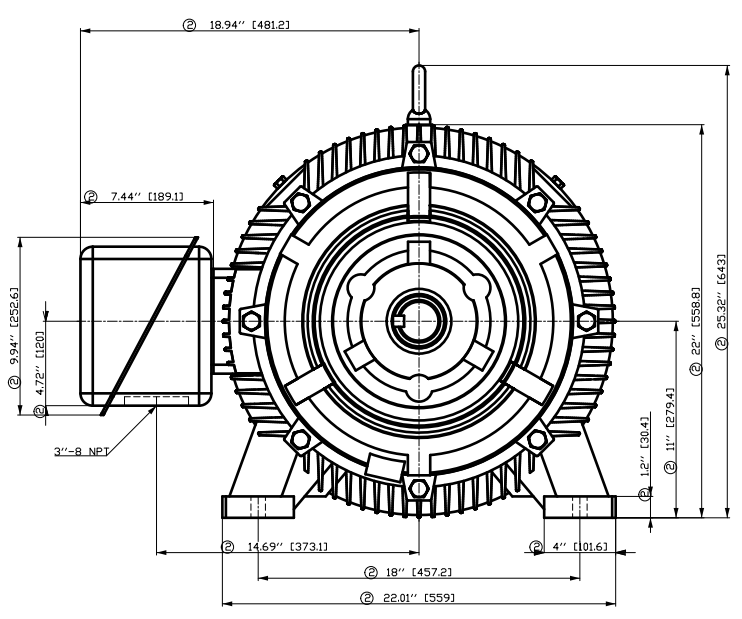

- ① Tolerances according to NEMA std.
- ② All these dimensions corresponding to assemblies and castings shall have a tolerance as per DIN standard 1686-GTB 19.
- ③ Not according to NEMA std.

Tolerance	Surface	Material	Weight	Scale	
F50GGGF8 ÖÖI F800EH	Author	ÖS Tæ: ^æ@` }*	E		
E	Creator				ÖVS
	Approval				
	Department				
	Change Order	MLFB	Doc Type	/	
	Doc. State	I 888	Item No	Paper Size	
	Revision	Index	RS	1st Language	
				2nd Language	
© Siemens AG 2018	Project No	E	Ref No	E	
			Sheet	F of F	

SIEMENS INDUSTRY, INC.

HP 200 VOLTS < 600V RPM 1200 TYPE GP100
HZ 60 PHASE 3 FRAME 449TS NEMA B

TORQUE & CURRENT VS. SPEED

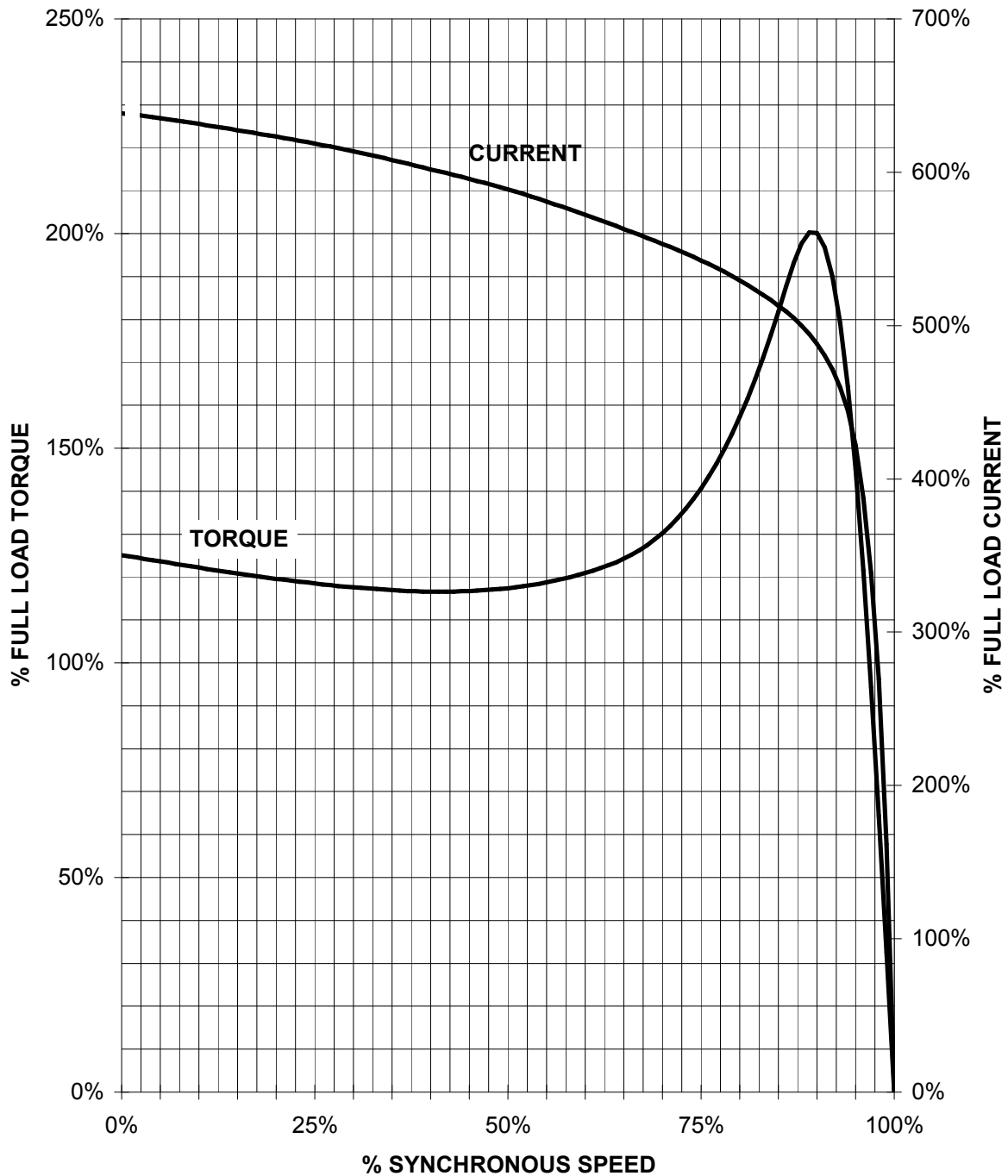

CUSTOMER: _____ ORDER#: _____

200 HP 1200 RPM 449TS FRAME 460 VOLTS 3 PHASE NEMA DESIGN B

SIEMENS INDUSTRY, INC.
PERFORMANCE CURVE
GP100

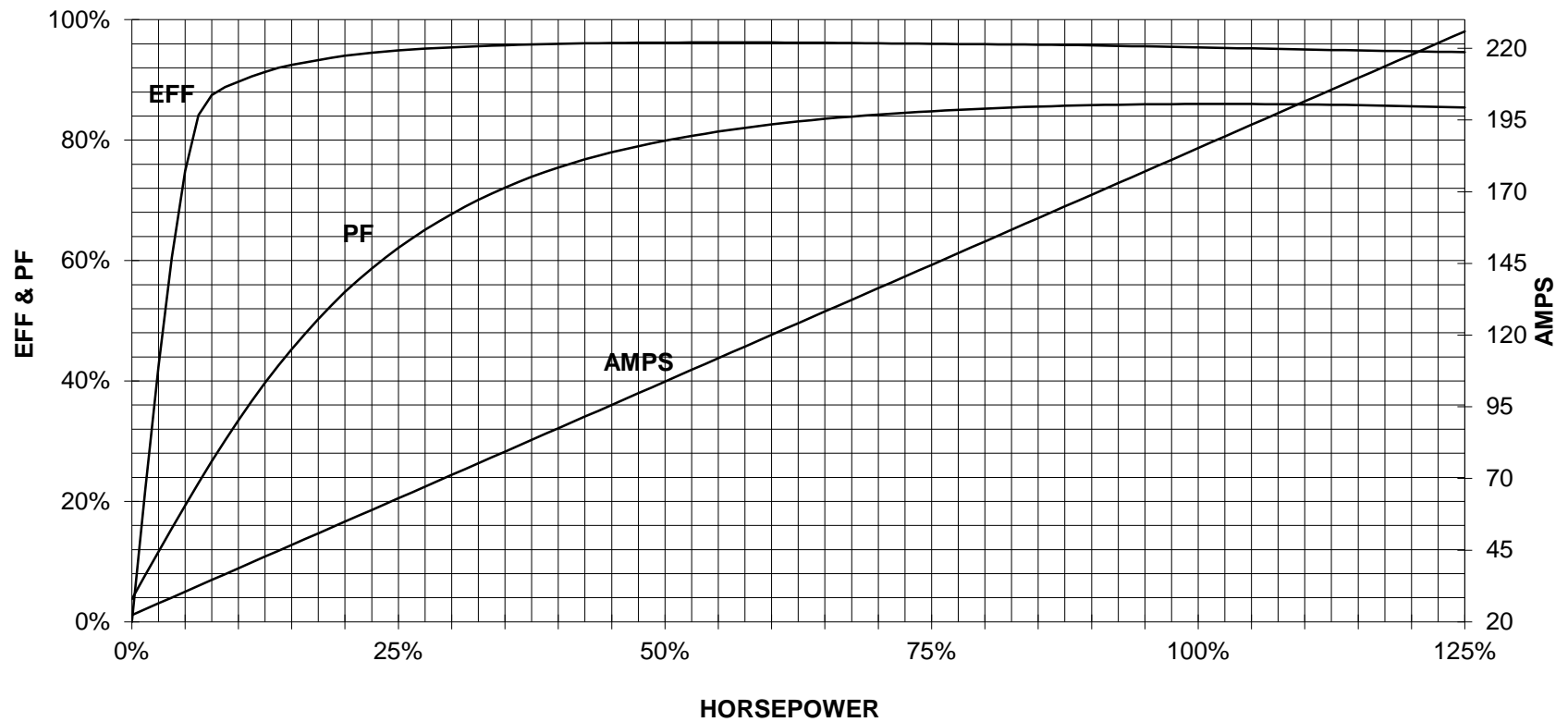

CUSTOMER _____ ORDER # _____ PO # _____

PERFORMANCE BASED ON DESIGN CALCULATIONS. SUBJECT TO CHANGE WITHOUT NOTICE.

REV. 1

Main terminal diagram

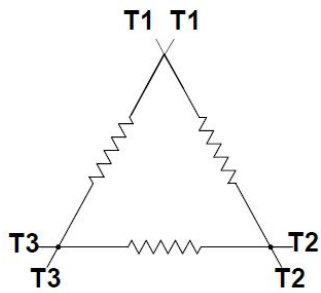

6 LEAD DELTA			
LINES			CONN.
L1	L2	L3	
T1	T2	T3	Δ

responsible dep. DI MC LVM	technical reference	created by	approved by	Project		
	document type Wiring Diagram		document status free		customer	
	title 1LE2221-4DC51-2AA3		document number			
© Siemens AG 2019			rev. 01	creation date 12/03/2019	language en	Page 1/1