

# Data sheet for three-phase Squirrel-Cage-Motors SIMOTICS

Motor type: **SD100** FS: **143T - 4p - 1 hp -**

Client order no.	Item-No.	Offer no.
Order no.	Consignment no.	Project
Remarks		

## Electrical data

Class I Division 2 Gr. A, B, C or D, T3

U [V]	$\Delta/Y$	f [Hz]	P [HP]	P [kW]	n [rpm]	I Load [Amps]					LRC	Nom. Eff Load [%]			Pwr. Factor Load [%]			Torque [lb-ft]	T <sub>A</sub> /T <sub>N</sub> LRT [%]	T <sub>k</sub> /T <sub>N</sub> BDT [%]
						4/4	3/4	1/2	0	4/4		3/4	2/4	4/4	3/4	2/4				
460	Y	60	1.00	0.75	1,800	1.40	1.20	1.00	0.80	13.0	85.5	85.4	83.4	78.2	71.5	58.4	3.0	300	383	
230	YY	60	1.00	0.75	1,800	2.80	2.30	1.92	1.60	26.0	85.5	85.4	83.4	78.2	71.5	58.4	3.0	300	383	
400	Y	50	0.75		1,463	1.25	1.08	0.94	0.81	11.9	80.8	80.3	77.8	74.7	65.2	51.3	2.7	378	543	
200	YY	50	0.75		1,463	2.50	2.16	1.88	1.62	23.8	80.8	80.3	77.8	74.7	65.2	51.3	2.7	378	543	

Frame Type: 143T	Type of constr.: (A) Foot mounted - End shield	Ins. Cl.: Standard Class F Insulation	Motor Prot.: (A) Without Protection	NEMA Des.: B	S.F.: 1.15
Mtr. WT: 72		Temp. Rise Cl.: B	Amb. Temp.: + 40 to -20 °C @1000 m	kVA: M	IP 55

## Mechanical data

Sound level (SPL / SWL) at 60 Hz	50.0 dB(A) / 62.0 dB(A)							Thickener	Polyurea
Octave Band Center Frequencies Hertz								Safe Stall Time Hot	18 s
	250	500	1000	2000	4000	8000	Hz	Safe Stall Time Cold	26 s
SPL@3	37.0	40.0	49.0	45.0	37.0	31.0	dB(A)	Frame material	cast iron
Moment of inertia	0.2 Lb-ft <sup>2</sup>							Color, paint shade	Standard Paint - RAL7030
Ext Load Inertia Capability:	58.0 Lb ft <sup>2</sup>							Coating (paint finish)	Standard Alkyed + Epoxy (C2)
<b>Bearings</b>								<b>Ventilation Type</b>	
Bearing DE   NDE	6205 Z C3 S0			6205 Z C3 S0				Method of cooling	TEFC
Bearing_Type	Ball Bearing			Ball Bearing				Direction of rotation	Bidirectional
AFBMA:	25BC02JP30			25BC02JP30				Fan Material	Polypropylen ESD
<b>Grease</b>								VFD	CT: 20:1 VT: 20:1
Capacity	0.1 oz			0.1 oz				Space heaters	without
Grease Type:	Exxon Mobile EM							Brake:	without

## Terminal box

Lead Wire Connection	9 LEAD - WYE				Terminal box position	(3) F-1, Standard Floor Mount, T. Box LHS
Voltage	L1	L1	L1	Connected together	Material of terminal box	Cast Iron
LOW	T1 T7	T2 T8	T3 T9	T4 T5 T6	Cable entry	.75" NPT
HIGH	T1	T2	T3	T4 T7-T5 T8-T6 T9		

## Notes:

I<sub>L</sub>/I<sub>N</sub> = locked rotor current / current nominal  
M<sub>L</sub>/M<sub>N</sub> = locked rotor torque / torque nominal  
M<sub>b</sub>/M<sub>N</sub> = break down torque / nominal torque  
3) Value is valid only for DOL operation with motor design IC411  
2) at rated power / at full load

responsible dep. DI MC LVM	technical reference	created by DT Configurator	approved by	<b>Technical data are subject to change! There may be discrepancies between software and hardware versions</b>			
	document type datasheet	document status released		customer			
	title 1LE2321-1AB21-4AA3	document number					
© Siemens AG 2022	rev. 01	creation date 2022-04-08 03:38	language en	Page 1/1			

刀絲... 用... 文... 紙... 1:1

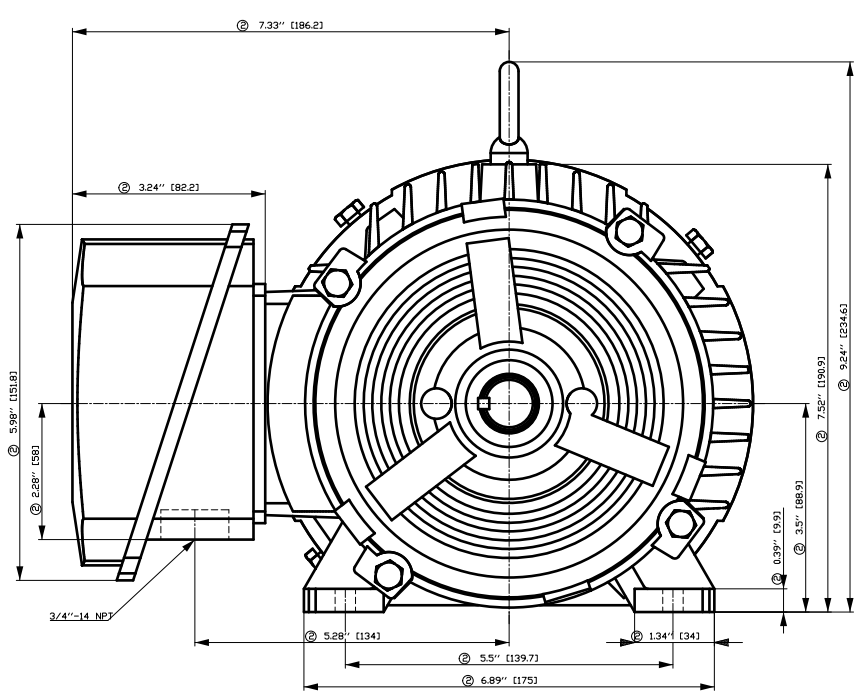

- ① Tolerances according to NEMA std.
- ② All these dimensions corresponding to assemblies and castings shall have a tolerance as per DIN standard 1686-GTB 19.
- ③ Not according to NEMA std.

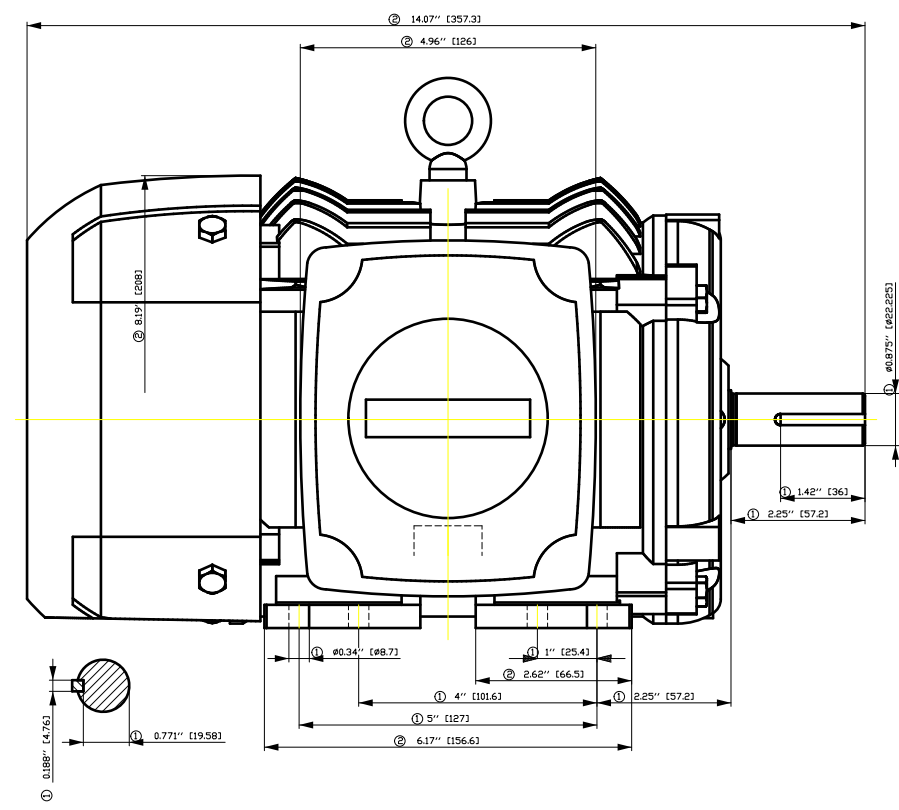

Tolerance	Surface	Material	Weight	Scale
F50GHGF00G00EH E	Author Creator Approval Department Change Order	ÖVS T: 10.000.000.000.000	E	{
	Doc. State	Item No.	Doc Type	
<b>SIEMENS</b>		Revision Index RS	Paper Size CH	1st Language ^
© Siemens AG 2018	Project No E	Ref No E	2nd Language a^	Sheet F of F

刀絲... 用... 文... 紙... 1:1

刀絲... 用... 文... 紙... 1:1

# SIEMENS INDUSTRY, INC.

HP 1 VOLTS < 600V RPM 1800 TYPE SD100  
HZ 60 PHASE 3 FRAME 143T NEMA B

## TORQUE & CURRENT VS. SPEED

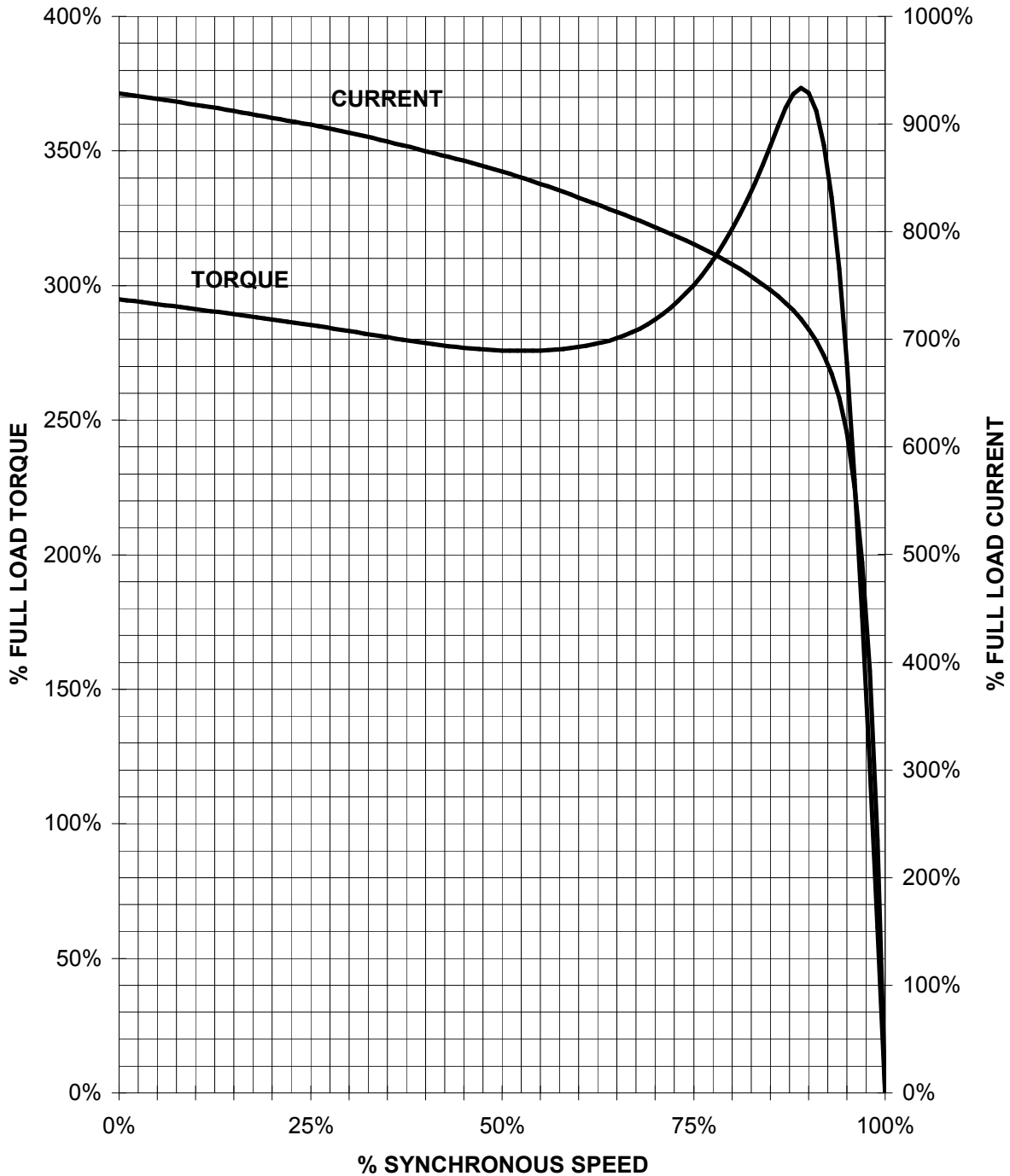

CUSTOMER: \_\_\_\_\_ ORDER#: \_\_\_\_\_

1 HP 1800 RPM 143T FRAME 460 VOLTS 3 PHASE NEMA DESIGN B

**SIEMENS INDUSTRY, INC.**  
PERFORMANCE CURVE  
SD100

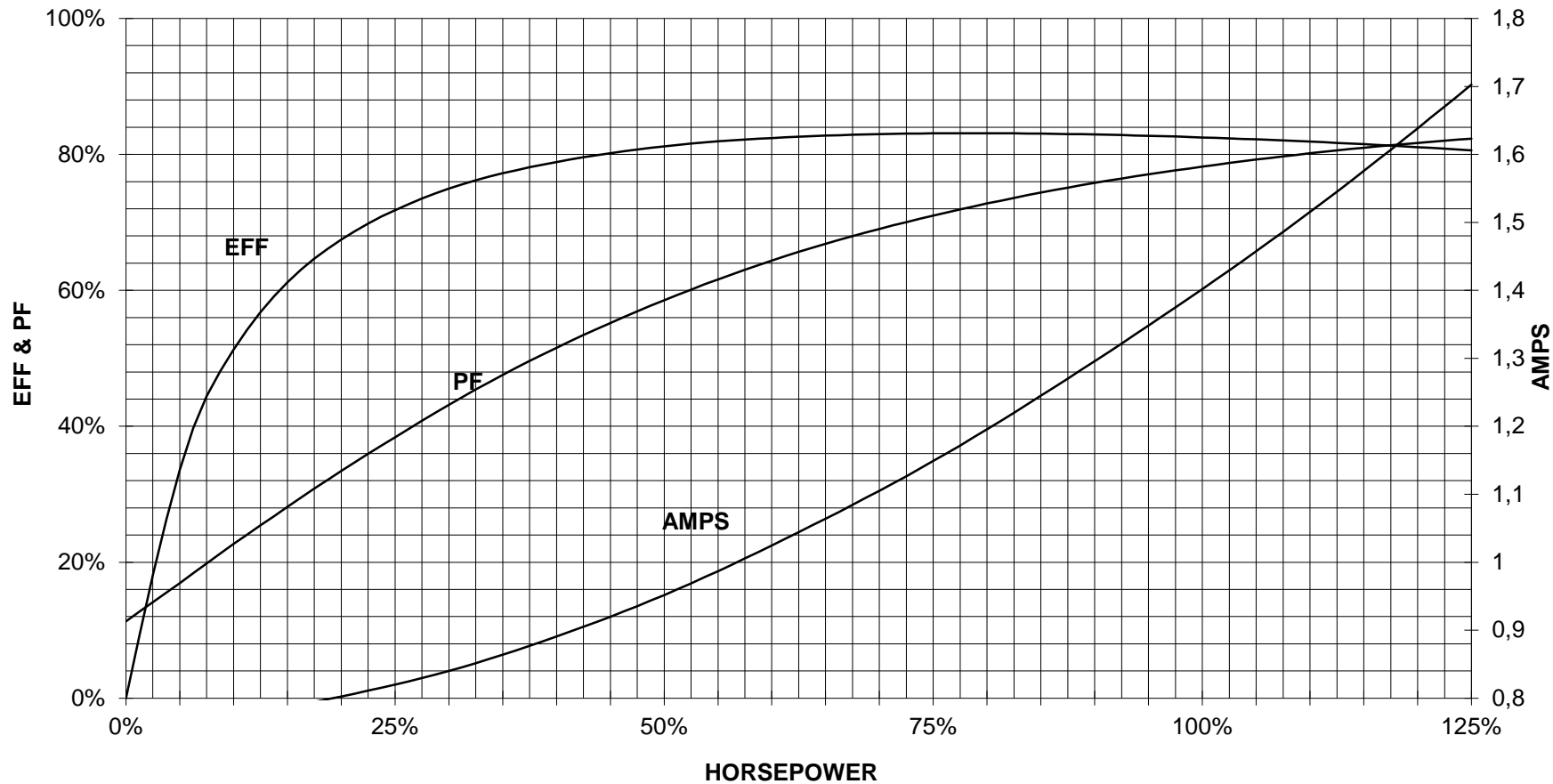

CUSTOMER \_\_\_\_\_ ORDER # \_\_\_\_\_ PO # \_\_\_\_\_

PERFORMANCE BASED ON DESIGN CALCULATIONS. SUBJECT TO CHANGE WITHOUT NOTICE.

REV. 1

Main terminal diagram

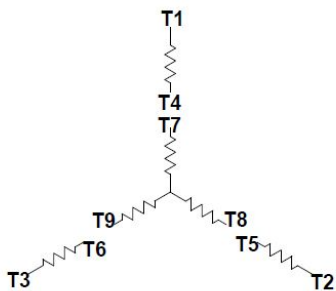

9 LEAD WYE					
Volts	LINES			CONNECTED TOGETHER	CONN.
	L1	L2	L3		
LOW	T1 T7	T2 T6	T3 T9	T4 T5 T6	YY
HIGH	T1	T2	T3	T4 T7-T5 T8-T6 T9	Y

responsible dep. DI MC LVM	technical reference	created by	approved by	Project
<b>SIEMENS</b>	document type Wiring Diagram	document status free		customer
	title 1LE2321-1AB21-4AA3	document number		
© Siemens AG 2019	rev. 01	creation date 12/03/2019	language en	Page 1/1