

# Data sheet for three-phase Squirrel-Cage-Motors SIMOTICS

Motor type: **SD100** FS: 213T - 2p - 7.5 hp -

Client order no.	Item-No.	Offer no.
Order no.	Consignment no.	Project
Remarks		

## Electrical data

Class I Division 2 Gr. A, B, C or D, T3

U [V]	$\Delta/Y$	f [Hz]	P [HP]	P [kW]	n [rpm]	I Load [Amps]					LRC	Nom. Eff Load [%]			Pwr. Factor Load [%]			Torque [lb-ft]	T <sub>A</sub> /T <sub>N</sub> LRT [%]	T <sub>k</sub> /T <sub>N</sub> BDT [%]
						4/4	3/4	1/2	0	4/4		3/4	2/4	4/4	3/4	2/4				
575	Y	60	7.50	5.50	3,600	7.00	5.40	4.00	2.40	50.4	89.5	90.1	89.6	89.2	86.8	78.5	11.0	182	500	
Frame Type: 213T		Type of constr.: (A) Foot mounted - End shield				Ins. Cl.: Standard Class F Insulation		Motor Prot.: (A) Without Protection			NEMA Des.: B		S.F.: 1.15							
Mtr. WT: 161						Temp. Rise Cl.: B		Amb. Temp.: + 40 to -20 °C @1000 m			kVA: H		IP 55							

## Mechanical data

Sound level (SPL / SWL) at 60 Hz	66.0 dB(A) / 78.0 dB(A)		Thickener	Polyurea					
Octave Band Center Frequencies Hertz			Safe Stall Time Hot	17 s					
	250	500	1000	2000	4000	8000	Hz	Safe Stall Time Cold	30 s
SPL@3	53.0	55.0	63.0	62.0	58.0	47.0	dB(A)	Frame material	cast iron
Moment of inertia	0.4 Lb-ft <sup>2</sup>		Color, paint shade	Standard Paint - RAL7030					
Ext Load Inertia Capability:	83.0 Lb ft <sup>2</sup>		Coating (paint finish)	Standard Alkyed + Epoxy (C2)					
<b>Bearings</b>			<b>Ventilation Type</b>						
Bearing DE   NDE	6208 Z C3 S0		6208 Z C3 S0	Method of cooling	TEFC				
Bearing_Type	Ball Bearing		Ball Bearing	Direction of rotation	Bidirectional				
AFBMA:	40BC02JP30		40BC02JP30	Fan Material	Polypropylen ESD				
<b>Grease</b>			VFD	CT: 4:1 VT: 20:1					
Capacity	0.3 oz		0.3 oz	Space heaters	without				
Grease Type:	Exxon Mobile EM		Brake:	without					

## Terminal box

Lead Wire Connection	3 LEAD - WYE				Terminal box position	(3) F-1, Standard Floor Mount, T. Box LHS
Voltage	L1	L1	L1	Connected together	Material of terminal box	Cast Iron
----	----	----	----	----	Cable entry	1" NPT
----	T1	T2	T3	----		

### Notes:

I<sub>r</sub>/I<sub>N</sub> = locked rotor current / current nominal  
M<sub>r</sub>/M<sub>N</sub> = locked rotor torque / torque nominal  
M<sub>b</sub>/M<sub>N</sub> = break down torque / nominal torque

3) Value is valid only for DOL operation with motor design IC411  
2) at rated power / at full load

responsible dep. DI MC LVM	technical reference	created by DT Configurator	approved by	<i>Technical data are subject to change! There may be discrepancies between software and hardware versions</i>	
	document type datasheet	document status released	customer		
	title 1LE2321-2AA11-3AA3	document number			
© Siemens AG 2022	rev. 01	creation date 2022-04-08 18:19	language en	Page 1/1	

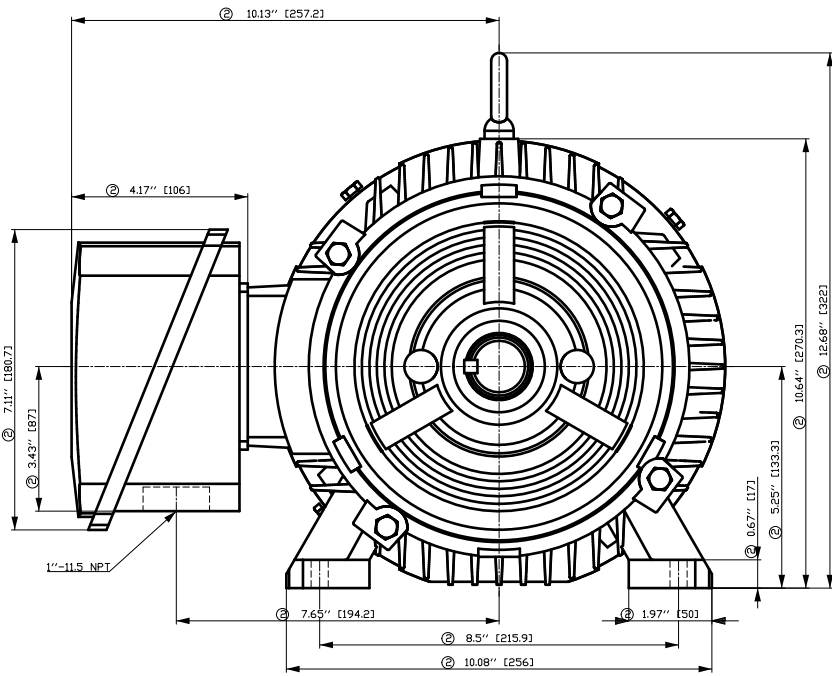

- ① Tolerances according to NEMA std.
- ② All these dimensions corresponding to assemblies and castings shall have a tolerance as per DIN standard 1686-GTB 19.
- ③ Not according to NEMA std.

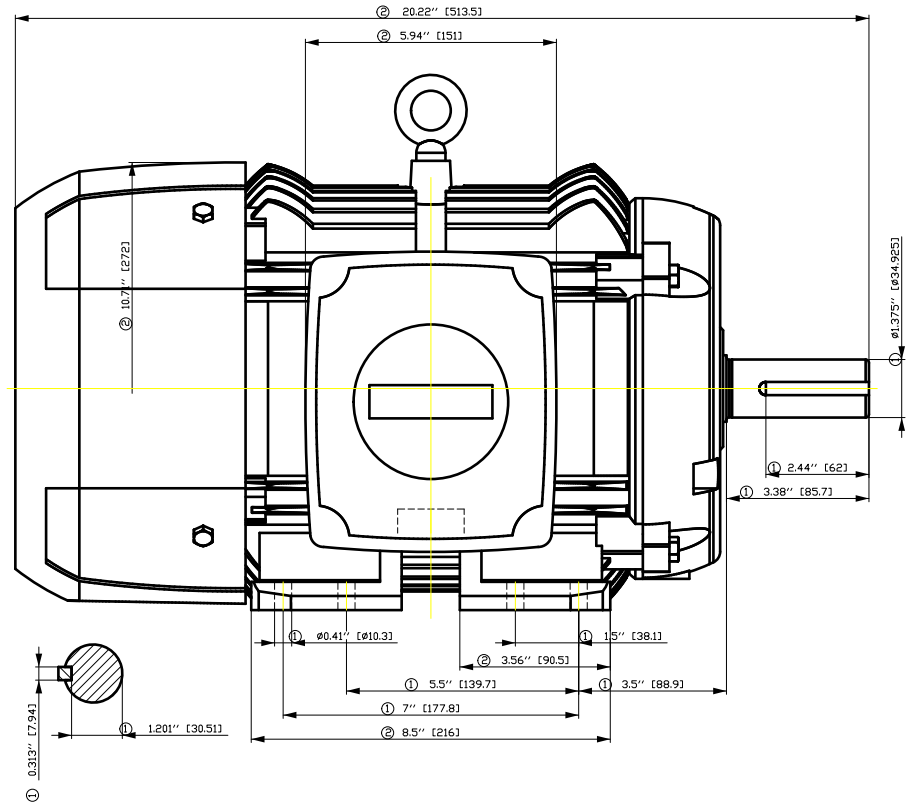

Tolerance	Surface	Material	Weight	Scale
F50G-GF00FF00H E	Author Creator Approval Department Change Order	ÖVS T a : ^ & @ } *	E	{ {
SIEMENS	Doc. State	I B B G	MLFB	Doc. Type
	Revision	Index RS	Item No Doc No	Paper Size CH 1st Language ^ 2nd Language â
© Siemens AG 2018	Project No	E	Ref No	E
				Sheet F of F

# SIEMENS INDUSTRY, INC.

HP 7,5 VOLTS < 600V RPM 3600 TYPE SD100  
HZ 60 PHASE 3 FRAME 213T NEMA B

## TORQUE & CURRENT VS. SPEED

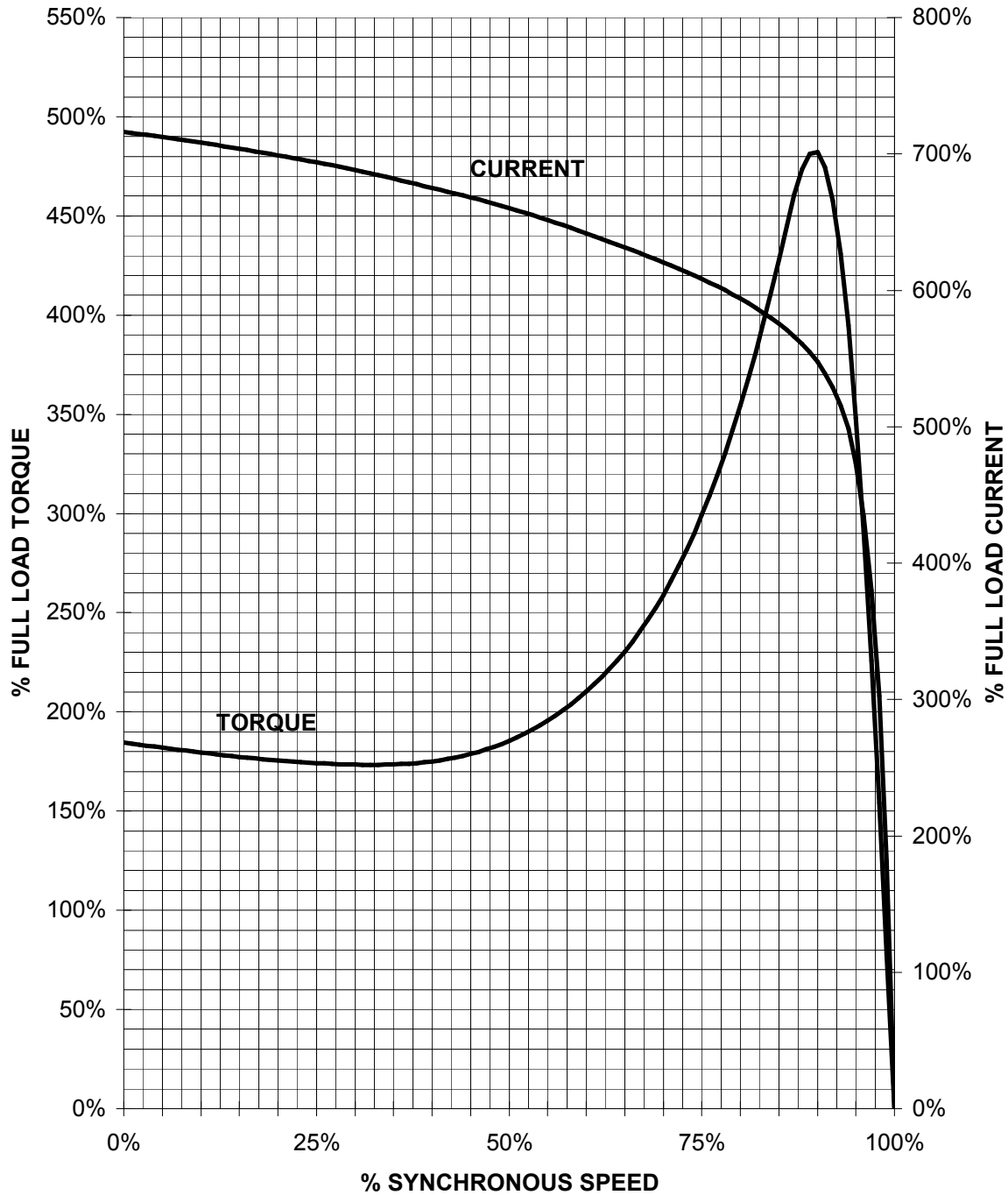

CUSTOMER: \_\_\_\_\_ ORDER#: \_\_\_\_\_

7.5 HP 3600 RPM 213T FRAME 575 VOLTS 3 PHASE NEMA DESIGN B

**SIEMENS INDUSTRY, INC.**  
**PERFORMANCE CURVE**  
**SD100**

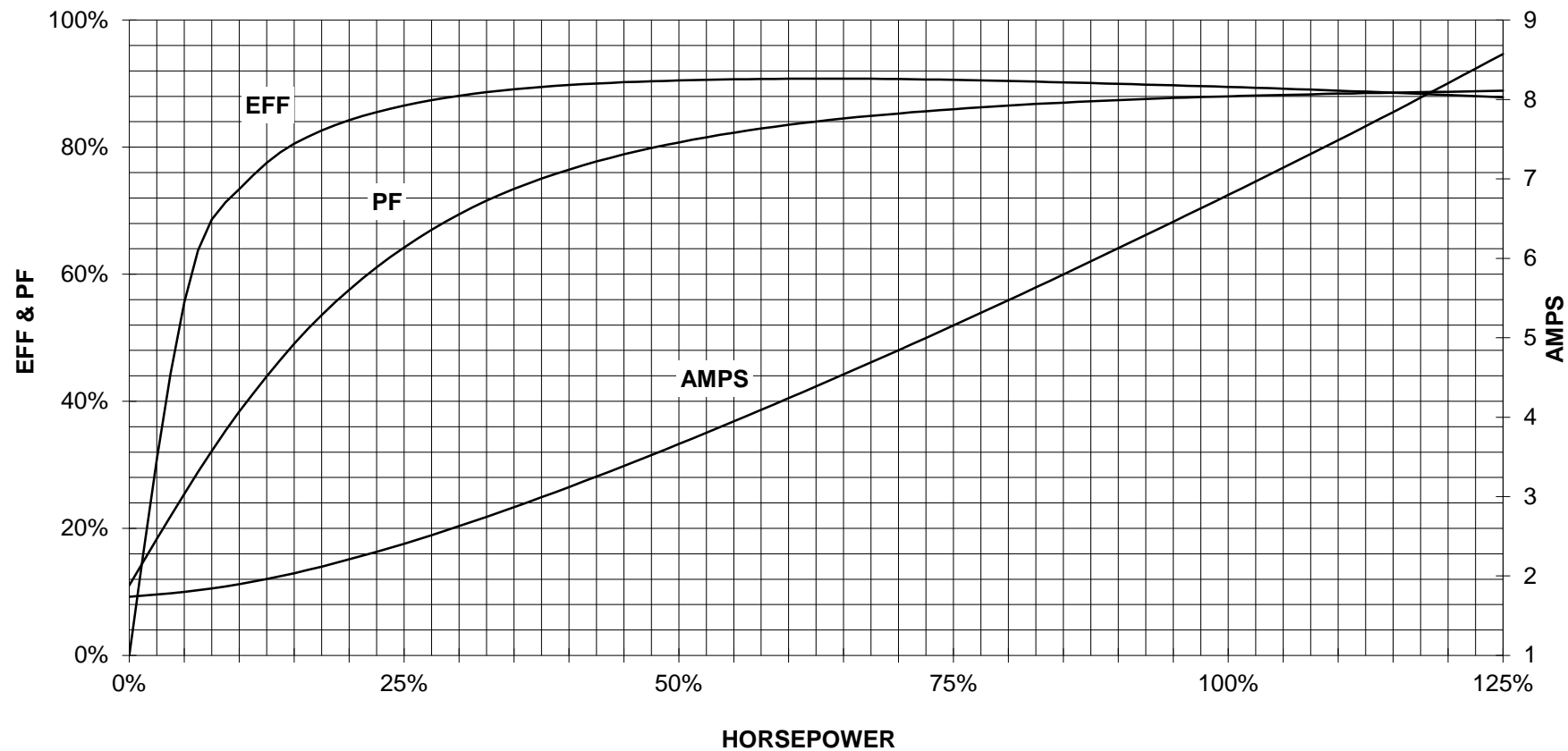

CUSTOMER \_\_\_\_\_ ORDER # \_\_\_\_\_ PO # \_\_\_\_\_

PERFORMANCE BASED ON DESIGN CALCULATIONS. SUBJECT TO CHANGE WITHOUT NOTICE.

REV. 1

Main terminal diagram



3 LEAD WYE			
LINES			CONN.
L1	L2	L3	
T1	T2	T3	Y

responsible dep.  
DI MC LVM

technical reference

created by

approved by

Project

**SIEMENS**

document type  
Wiring Diagram

title  
1LE2321-2AA11-3AA3

document status  
free

document number

customer