

Data sheet for three-phase Squirrel-Cage-Motors SIMOTICS

Motor type: **SD100** FS: 215T - 2p - 10 hp -

Client order no.	Item-No.	Offer no.
Order no.	Consignment no.	Project

Remarks

Electrical data

Class I Division 2 Gr. A, B, C or D, T3

U [V]	Δ/Y	f [Hz]	P [HP]	P [kW]	n [rpm]	I Load [Amps]					LRC	Nom. Eff Load [%]			Pwr. Factor Load [%]			Torque [lb-ft]	T _A /T _N LRT [%]	T _k /T _N BDT [%]
						4/4	3/4	1/2	0	4/4		3/4	2/4	4/4	3/4	2/4				
460	Y	60	10.00	7.50	3,600	11.50	8.70	6.30	3.50	81.0	90.2	91.1	91.0	90.3	88.8	81.5	15.0	180	440	
230	YY	60	10.00	7.50	3,600	23.00	17.36	12.63	7.00	162.0	90.2	91.1	91.0	90.3	88.8	81.5	15.0	180	440	
400	Y	50	7.50		2,933	10.10	7.99	6.17	4.22	84.0	89.2	89.8	89.8	89.0	84.9	75.4	13.5	235	400	
200	YY	50	7.50		2,933	20.20	15.98	12.34	8.44	168.0	89.2	89.8	89.8	89.0	84.9	75.4	13.5	235	400	

Frame Type: 215T	Type of constr.: (G) Round body - C-Face	Ins. Cl.: Standard Class F Insulation	Motor Prot.: (A) Without Protection	NEMA Des.: B	S.F.: 1.15
Mtr. WT: 218		Temp. Rise Cl.: B	Amb. Temp.: + 40 to -20 °C @1000 m	kVA: H	IP 55

Mechanical data

Sound level (SPL / SWL) at 60 Hz	66.0 dB(A) / 78.0 dB(A)							Thickener	Polyurea
Octave Band Center Frequencies Hertz								Safe Stall Time Hot	14 s
	250	500	1000	2000	4000	8000	Hz	Safe Stall Time Cold	28 s
SPL@3	53.0	55.0	63.0	62.0	58.0	47.0	dB(A)	Frame material	cast iron
Moment of inertia	0.5 Lb-ft ²							Color, paint shade	Standard Paint - RAL7030
Ext Load Inertia Capability:	11.0 Lb ft ²							Coating (paint finish)	Standard Alkyed + Epoxy (C2)
Bearings								Ventilation Type	
Bearing DE NDE	6208 Z C3 S0			6208 Z C3 S0				Method of cooling	TEFC
Bearing_Type	Ball Bearing			Ball Bearing				Direction of rotation	Bidirectional
AFBMA:	40BC02JP30			40BC02JP30				Fan Material	Polypropylen ESD
Grease								VFD	CT: 4:1 VT: 20:1
Capacity	0.3 oz			0.3 oz				Space heaters	without
Grease Type:	Exxon Mobile EM							Brake:	without

Terminal box

Lead Wire Connection	9 LEAD - WYE				Terminal box position	(3) F-1, Standard Floor Mount, T. Box LHS
Voltage	L1	L1	L1	Connected together	Material of terminal box	Cast Iron
LOW	T1 T7	T2 T8	T3 T9	T4 T5 T6	Cable entry	1" NPT
HIGH	T1	T2	T3	T4 T7-T5 T8-T6 T9		

Notes:

I_L/I_N = locked rotor current / current nominal
M_L/M_N = locked rotor torque / torque nominal
M_d/M_N = break down torque / nominal torque

3) Value is valid only for DOL operation with motor design IC411
2) at rated power / at full load

responsible dep. DI MC LVM	technical reference	created by DT Configurator	approved by	<i>Technical data are subject to change! There may be discrepancies between software and hardware versions.</i>
-------------------------------	---------------------	-------------------------------	-------------	---

	document type datasheet	document status released	customer	
	title 1LE2321-2AA21-4GA3	document number	rev. 01	creation date 2022-04-08 18:21
© Siemens AG 2022				Page 1/1

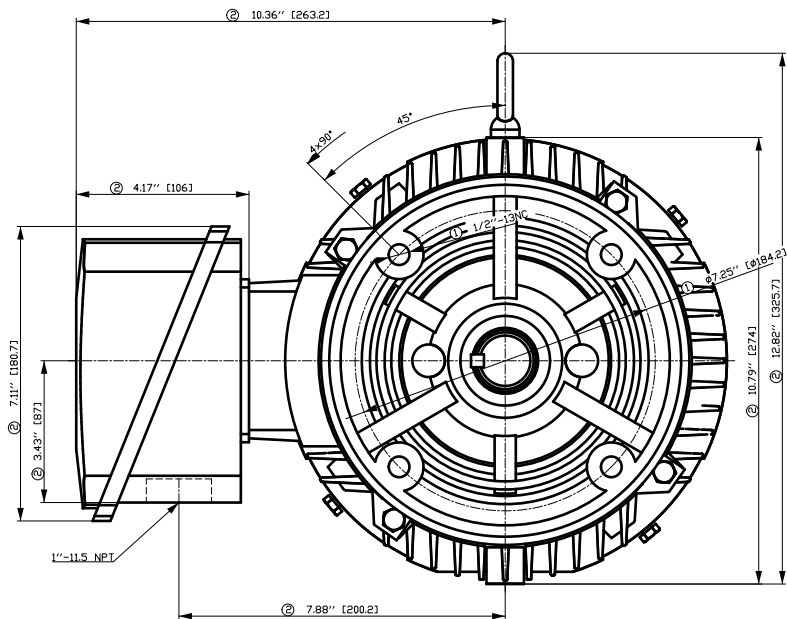

- ① Tolerances according to NEMA std.
- ② All these dimensions corresponding to assemblies and castings shall have a tolerance as per DIN standard 1686-GTB 19.
- ③ Not according to NEMA std.

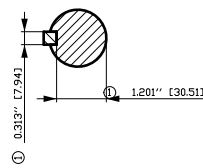
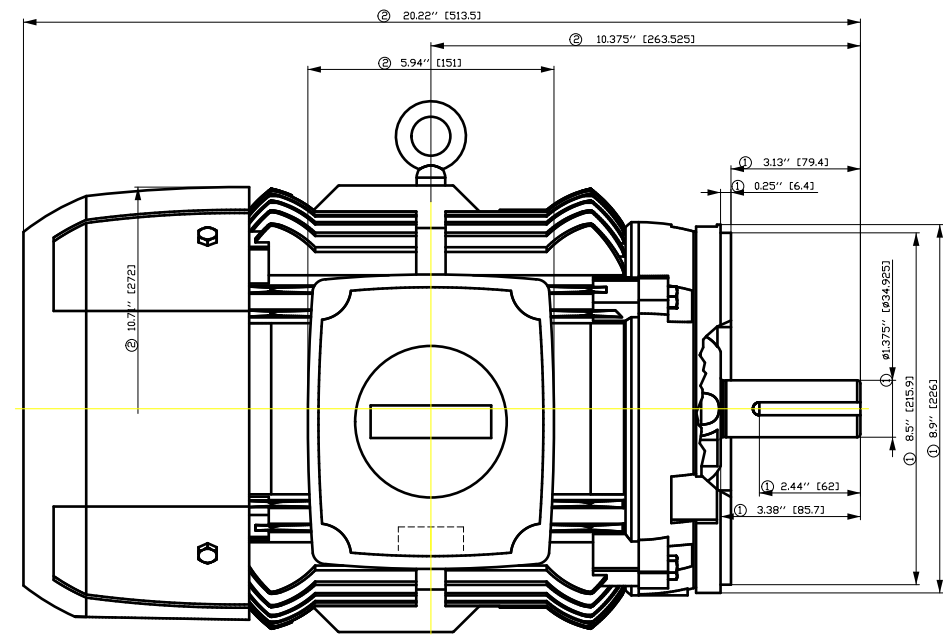

Tolerance	Surface	Material	Weight	Scale
F50G-HF000E-ÖCH	Author	ÖS	Weight	Scale
E	Creator	ÖVS		
	Approval	T a : ^ @ } *		
	Department			
	Change Order	MFB	Doc Type	
	Doc State	I B B G	Item No	Paper Size CH
	Revision	Index RS	Doc No	1st Language ^
				2nd Language a^
© Siemens AG 2018	Project No E	Ref No E		Sheet F of F

刀线需
用英文
标注
尺寸
单位
mm
公差
按
DIN
1686-
GTB
19
执行
所有
尺寸
均按
实际
情况
标注
如有
变更
请
及时
通知
设计
人员
确认
签字
日期

SIEMENS INDUSTRY, INC.

HP 10 VOLTS < 600V RPM 3600 TYPE SD100
HZ 60 PHASE 3 FRAME 215T NEMA B

TORQUE & CURRENT VS. SPEED

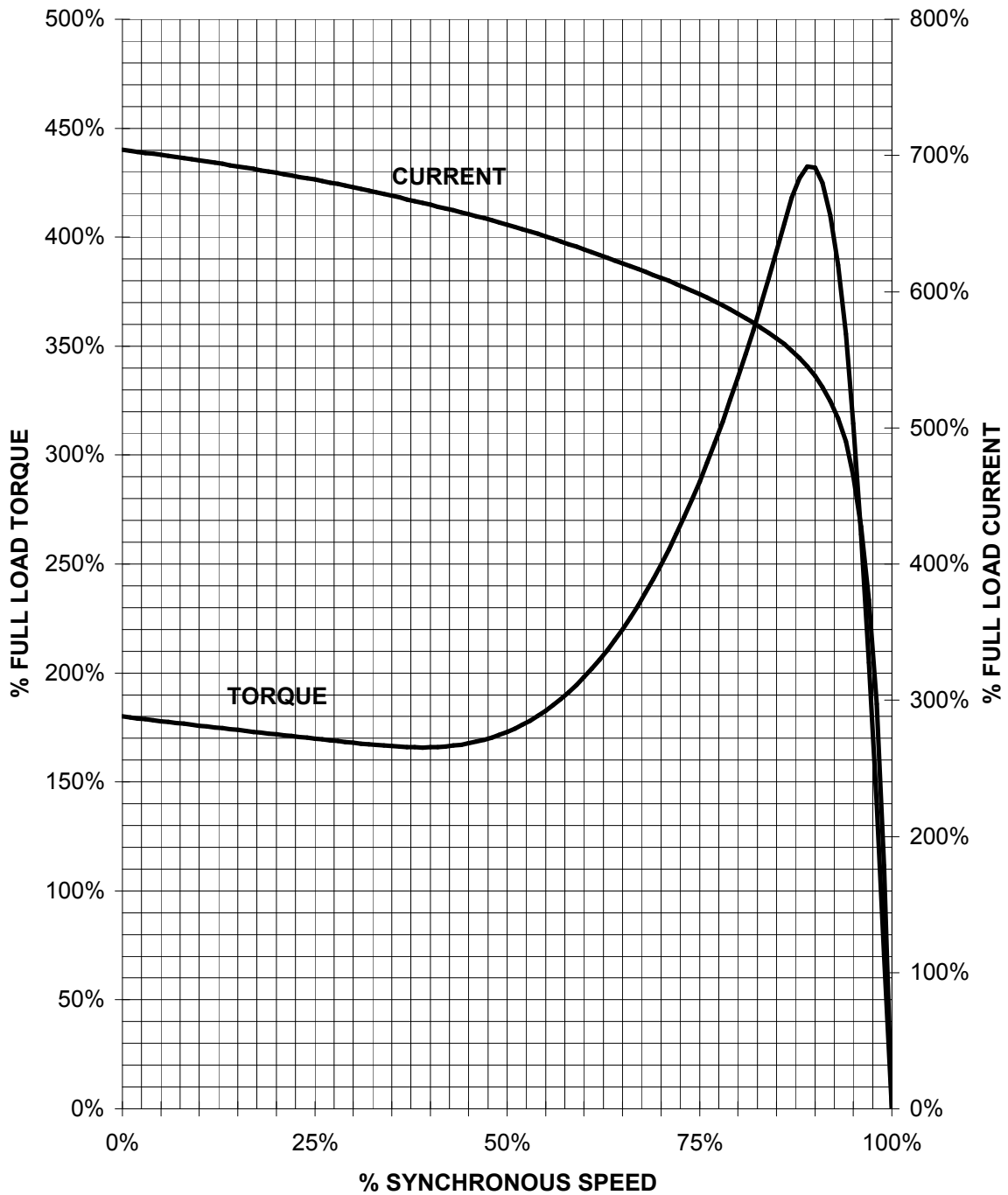

CUSTOMER: _____ ORDER#: _____

10 HP 3600 RPM 215T FRAME 460 VOLTS 3 PHASE NEMA DESIGN B

SIEMENS INDUSTRY, INC.
PERFORMANCE CURVE
SD100

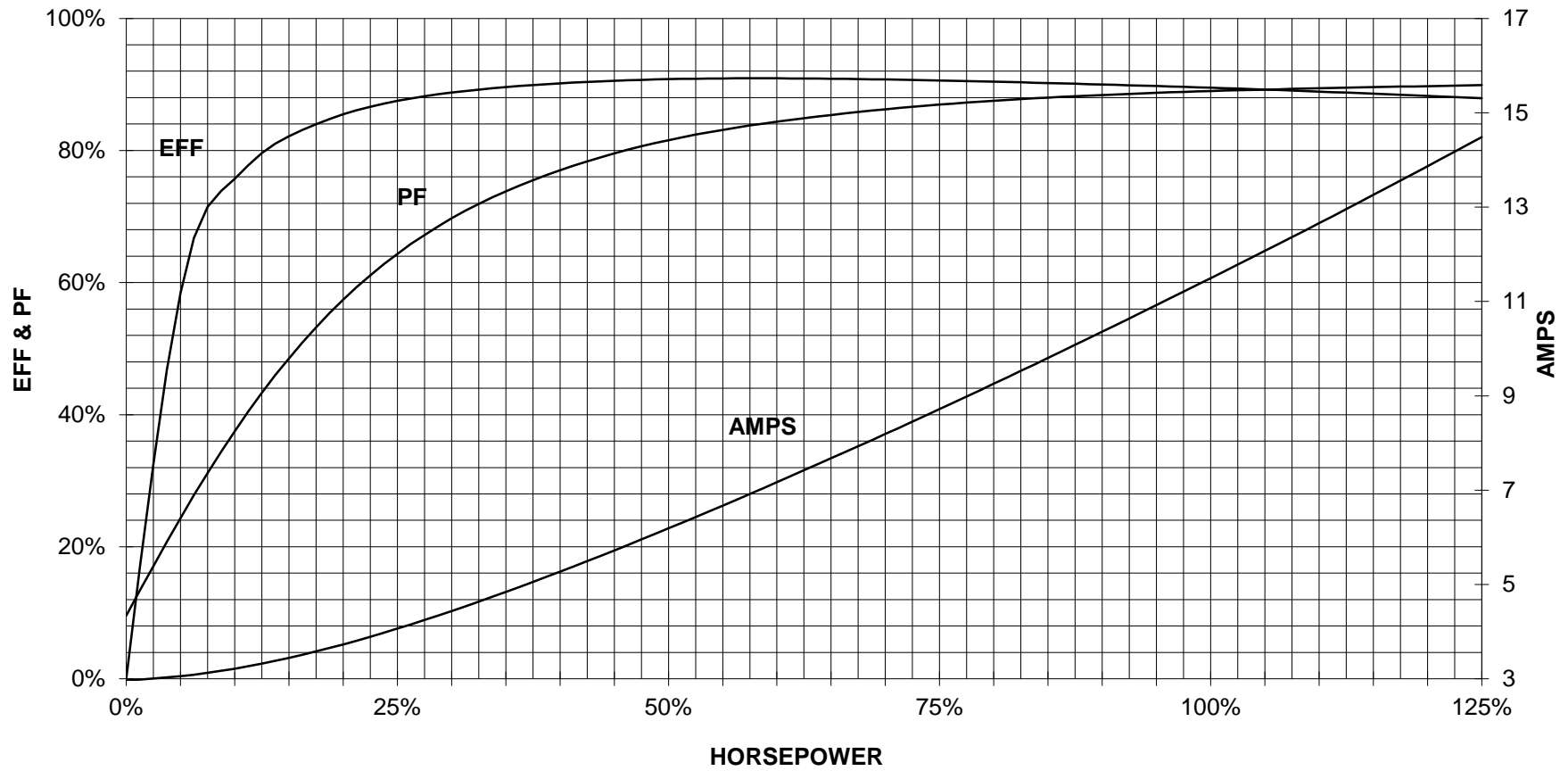

CUSTOMER _____ ORDER # _____ PO # _____

PERFORMANCE BASED ON DESIGN CALCULATIONS. SUBJECT TO CHANGE WITHOUT NOTICE.

REV. 1

Main terminal diagram

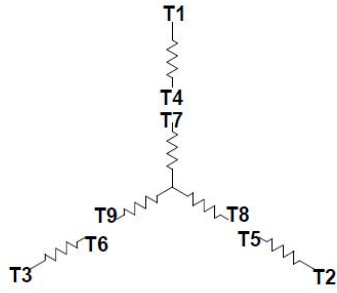

9 LEAD WYE						
Volts	LINES			CONNECTED TOGETHER	CONN.	
	L1	L2	L3			
LOW	T1 T7	T2 T6	T3 T9	T4 T5 T6	YY	
HIGH	T1	T2	T3	T4 T7-T5 T8-T6 T9	Y	

responsible dep. DI MC LVM	technical reference	created by	approved by	Project
SIEMENS	document type Wiring Diagram	document status free		customer
	title 1LE2321-2AA21-4GA3	document number		
© Siemens AG 2019	rev. 01	creation date 12/03/2019	language en	Page 1/1