

Data sheet for three-phase Squirrel-Cage-Motors SIMOTICS

Motor type: **SD100** FS: **213T - 6p - 3 hp -**

Client order no.	Item-No.	Offer no.
Order no.	Consignment no.	Project
Remarks		

Electrical data

Class I Division 2 Gr. A, B, C or D, T3

U [V]	Δ/Y	f [Hz]	P [HP]	P [kW]	n [rpm]	I Load [Amps]					LRC	Nom. Eff Load [%]			Pwr. Factor Load [%]			Torque [lb-ft]	T _A /T _N LRT [%]	T _k /T _N BDT [%]
						4/4	3/4	1/2	0	4/4		3/4	2/4	4/4	3/4	2/4				
460	Y	60	3.00	2.00	1,200	4.30	3.60	3.10	2.50	32.0	89.5	89.3	87.8	73.0	65.4	52.1	13.4	265	470	
230	YY	60	3.00	2.00	1,200	8.60	7.21	6.14	5.00	64.0	89.5	89.3	87.8	73.0	65.4	52.1	13.4	265	470	
400	Y	50	2.00		982	3.76	3.33	2.99	2.67	31.6	82.5	81.7	79.1	64.1	54.8	41.9	10.7	363	670	
200	YY	50	2.00		982	7.52	6.66	5.98	5.34	63.1	82.5	81.7	79.1	64.1	54.8	41.9	10.7	363	670	

Frame Type: 213T	Type of constr.: (G) Round body - C-Face	Ins. Cl.: Standard Class F Insulation	Motor Prot.: (A) Without Protection	NEMA Des.: B	S.F.: 1.15
Mtr. WT: 176		Temp. Rise Cl.: B	Amb. Temp.: + 40 to -20 °C @1000 m	kVA: K	IP 55

Mechanical data

Sound level (SPL / SWL) at 60 Hz	64.0 dB(A) / 71.0 dB(A)							Thickener	Polyurea
Octave Band Center Frequencies Hertz								Safe Stall Time Hot	23 s
	250	500	1000	2000	4000	8000	Hz	Safe Stall Time Cold	35 s
SPL@3	42.0	52.0	64.0	54.0	47.0	34.0	dB(A)	Frame material	cast iron
Moment of inertia	0.6 Lb-ft ²							Color, paint shade	Standard Paint - RAL7030
Ext Load Inertia Capability:	44.0 Lb ft ²							Coating (paint finish)	Standard Alkyed + Epoxy (C2)
Bearings								Ventilation Type	
Bearing DE NDE	6208 Z C3 S0			6208 Z C3 S0				Method of cooling	TEFC
Bearing_Type	Ball Bearing			Ball Bearing				Direction of rotation	Bidirectional
AFBMA:	40BC02JP30			40BC02JP30				Fan Material	Polypropylen ESD
Grease								VFD	CT: 4:1 VT: 20:1
Capacity	0.3 oz			0.3 oz				Space heaters	without
Grease Type:	Exxon Mobile EM							Brake:	without

Terminal box

Lead Wire Connection	9 LEAD - WYE				Terminal box position	(3) F-1, Standard Floor Mount, T. Box LHS
Voltage	L1	L1	L1	Connected together	Material of terminal box	Cast Iron
LOW	T1 T7	T2 T8	T3 T9	T4 T5 T6	Cable entry	1" NPT
HIGH	T1	T2	T3	T4 T7-T5 T8-T6 T9		

Notes:

I_L/I_N = locked rotor current / current nominal
M_L/M_N = locked rotor torque / torque nominal
M_B/M_N = break down torque / nominal torque

3) Value is valid only for DOL operation with motor design IC411
2) at rated power / at full load

responsible dep. DI MC LVM	technical reference	created by DT Configurator	approved by	<i>Technical data are subject to change! There may be discrepancies between software and hardware versions</i>	
	document type datasheet	document status released	customer		
	title 1LE2321-2AC11-4GA3	document number			
© Siemens AG 2022	rev. 01	creation date 2022-04-08 18:26	language en	Page 1/1	

刀线等，用转为为口
 所文全路
 图
 积
 印
 各
 部
 份
 均
 按
 图
 样
 及
 说
 明
 书
 中
 的
 规
 定
 制
 作
 不
 得
 有
 任
 何
 修
 改
 或
 删
 减
 等
 行
 为
 违
 反
 本
 图
 样
 及
 说
 明
 书
 中
 的
 规
 定
 者
 将
 被
 追
 究
 法
 律
 责
 任
 各
 部
 份
 均
 按
 图
 样
 及
 说
 明
 书
 中
 的
 规
 定
 制
 作
 不
 得
 有
 任
 何
 修
 改
 或
 删
 减
 等
 行
 为
 违
 反
 本
 图
 样
 及
 说
 明
 书
 中
 的
 规
 定
 者
 将
 被
 追
 究
 法
 律
 责
 任

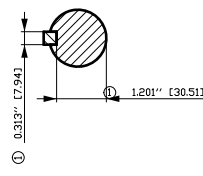
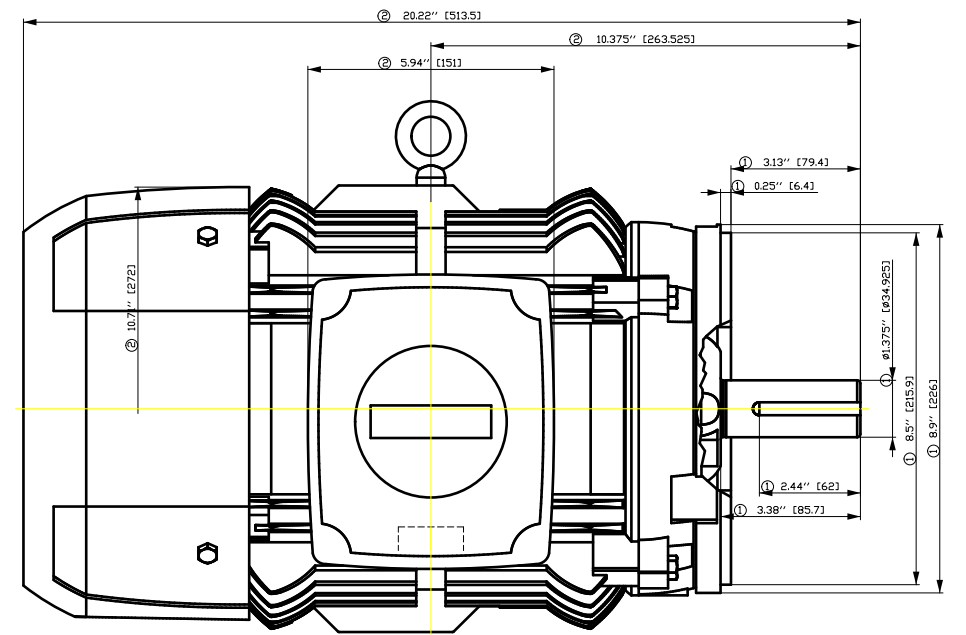
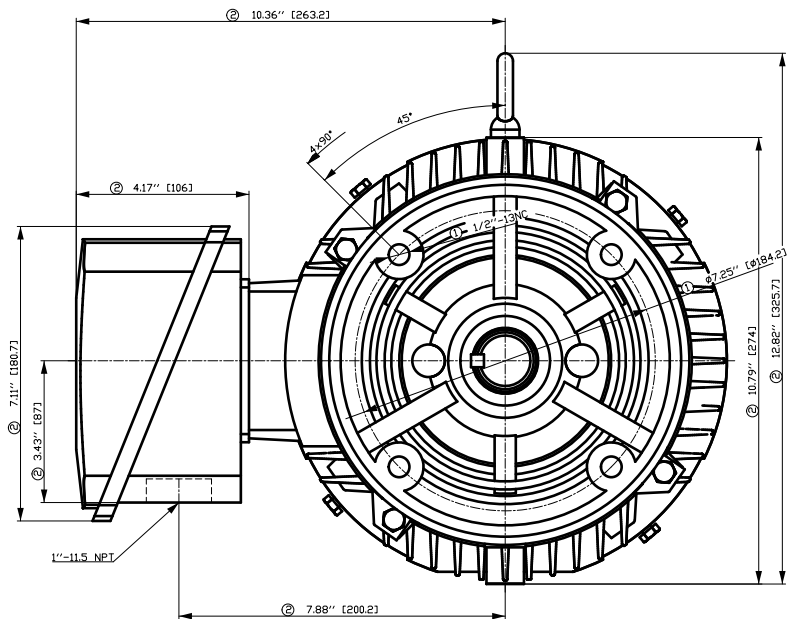

- ① Tolerances according to NEMA std.
- ② All these dimensions corresponding to assemblies and castings shall have a tolerance as per DIN standard 1686-GTB 19.
- ③ Not according to NEMA std.

Tolerance	Surface	Material	Weight	Scale	
F50G/GFC00FFB ÖCH	Author	Öa)•a)x/a)a)*	E		
E	Creator				ÖVS
	Approval				T a : ^a) } *
	Department	Change Order	MLFB	Doc Type	
SIEMENS	Doc State	I ð EEG	Item No	Paper Size	
	Revision	Index RS	Doc No	1st Language ^)	
© Siemens AG	Project No	E	Ref No	E	
2018				2nd Language a^	
				Sheet F of F	

SIEMENS INDUSTRY, INC.

HP 3 VOLTS < 600V RPM 1200 TYPE SD100
HZ 60 PHASE 3 FRAME 213T NEMA B

TORQUE & CURRENT VS. SPEED

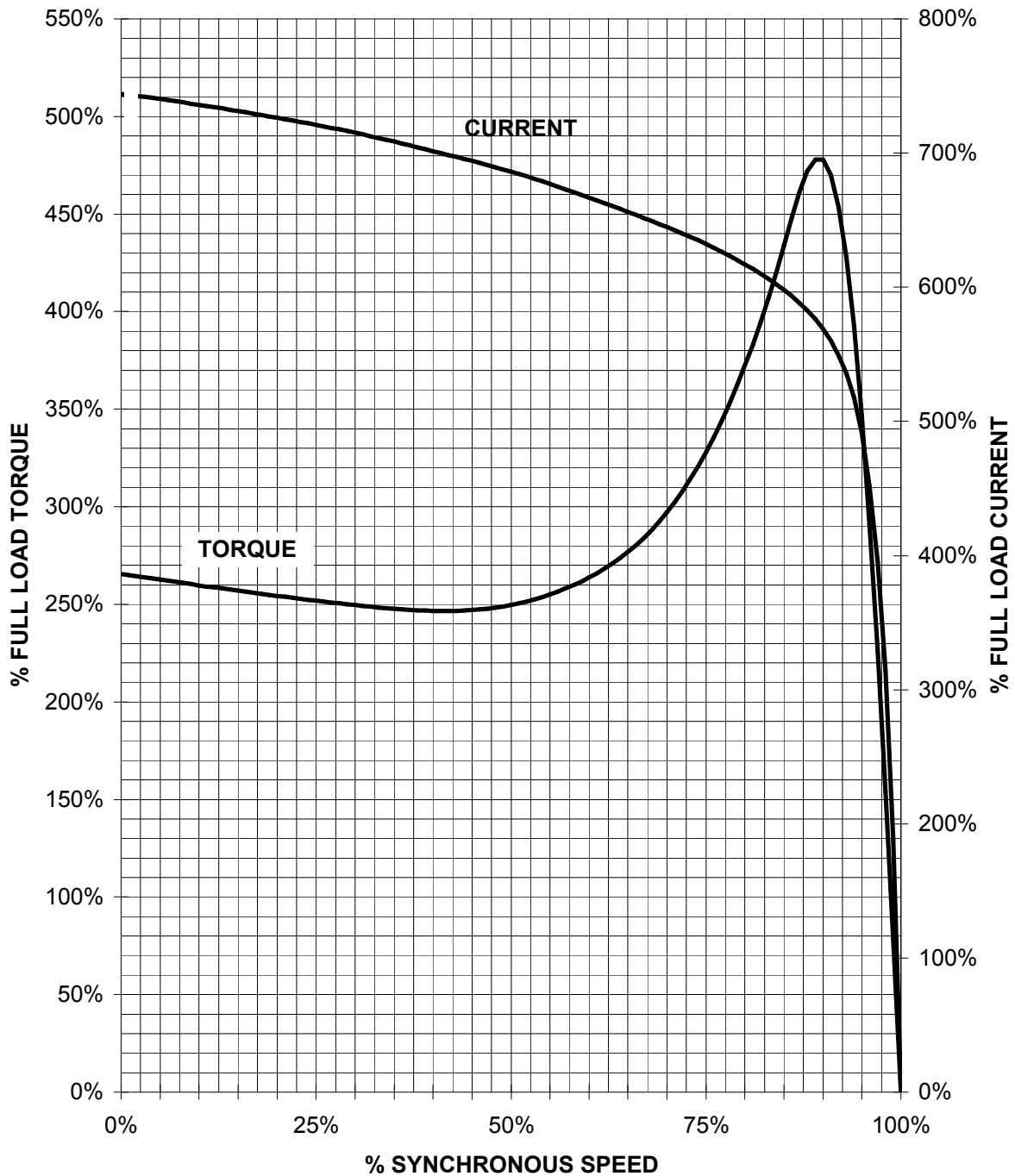

CUSTOMER: _____ ORDER#: _____

3 HP 1200 RPM 213T FRAME 460 VOLTS 3 PHASE NEMA DESIGN B

SIEMENS INDUSTRY, INC.
PERFORMANCE CURVE
SD100

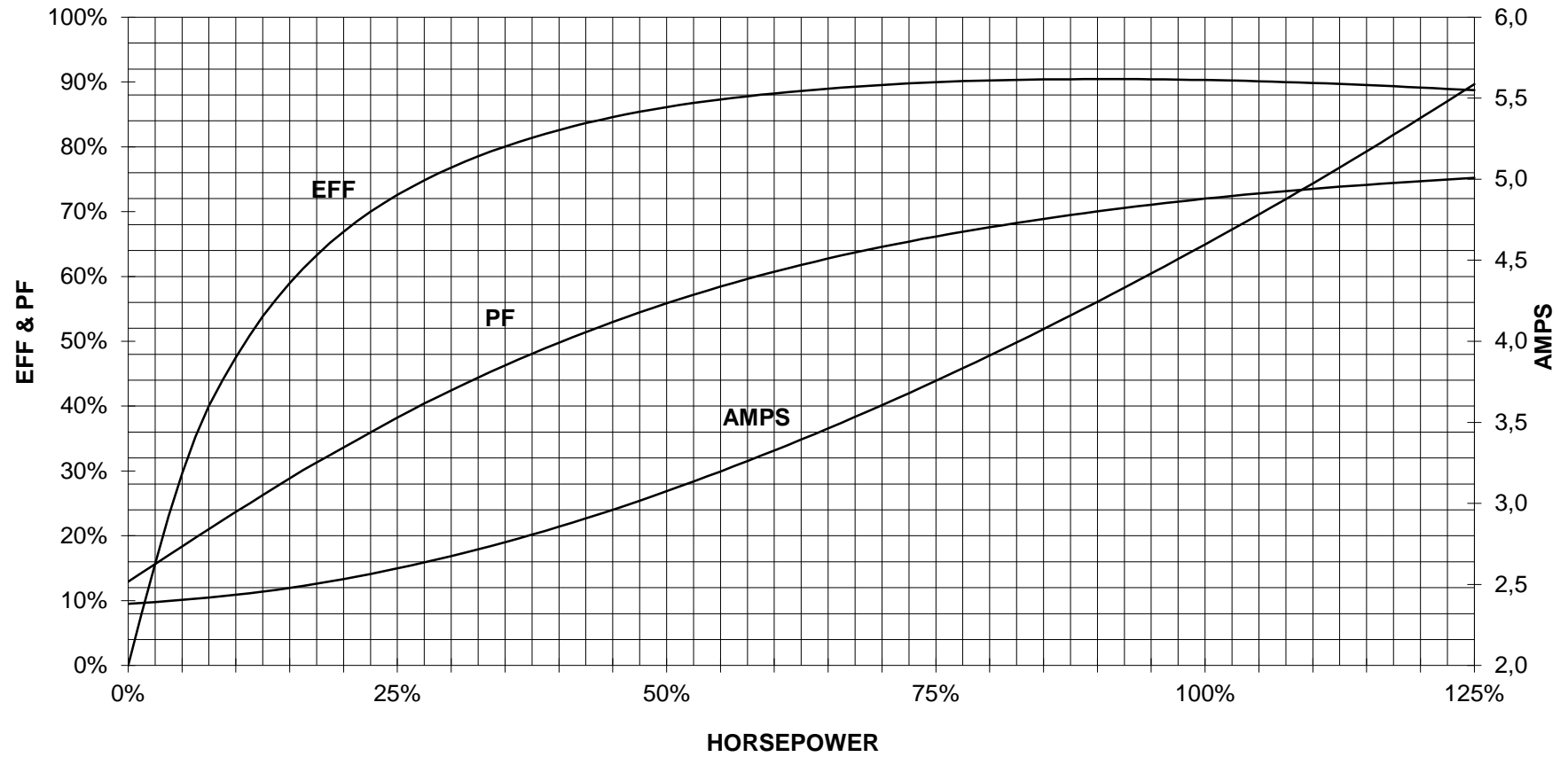

CUSTOMER _____ ORDER # _____ PO # _____

PERFORMANCE BASED ON DESIGN CALCULATIONS. SUBJECT TO CHANGE WITHOUT NOTICE.

REV. 1

Main terminal diagram

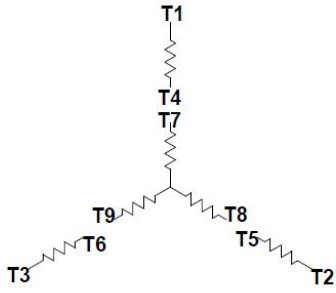

9 LEAD WYE						
Volts	LINES			CONNECTED TOGETHER	CONN.	
	L1	L2	L3			
LOW	T1 T7	T2 T6	T3 T9	T4 T5 T6	YY	
HIGH	T1	T2	T3	T4 T7-T5 T8-T6 T9	Y	

responsible dep. DI MC LVM	technical reference	created by	approved by	Project
SIEMENS	document type Wiring Diagram	document status free		customer
	title 1LE2321-2AC11-4GA3	document number		
© Siemens AG 2019	rev. 01	creation date 12/03/2019	language en	Page 1/1