

Data sheet for three-phase Squirrel-Cage-Motors SIMOTICS

Motor type: **SD100** FS: **254T - 6p - 7.5 hp -**

Client order no.	Item-No.	Offer no.
Order no.	Consignment no.	Project
Remarks		

Electrical data

Class I Division 2 Gr. A, B, C or D, T3

U [V]	Δ/Y	f [Hz]	P [HP]	P [kW]	n [rpm]	I Load [Amps]					LRC	Nom. Eff Load [%]			Pwr. Factor Load [%]			Torque [lb-ft]	T _A /T _N LRT [%]	T _k /T _N BDT [%]
						4/4	3/4	1/2	0	4/4		3/4	2/4	4/4	3/4	2/4				
460	Y	60	7.50	5.50	1,200	10.00	8.20	6.60	5.00	63.0	91.0	91.5	91.1	77.2	70.2	58.4	33.0	167	261	
230	YY	60	7.50	5.50	1,200	20.00	16.40	13.20	10.00	126.0	91.0	91.5	91.1	77.2	70.2	58.4	33.0	167	261	
400	Y	50	5.00		984	8.62	7.45	6.50	5.72	64.1	86.5	86.2	84.6	67.9	59.2	46.0	26.7	254	380	
200	YY	50	5.00		984	17.24	14.90	13.00	11.44	128.2	86.5	86.2	84.6	67.9	59.2	46.0	26.7	254	380	

Frame Type: 254T	Type of constr.: (A) Foot mounted - End shield	Ins. Cl.: Standard Class F Insulation	Motor Prot.: (A) Without Protection	NEMA Des.: B	S.F.: 1.15
Mtr. WT: 278		Temp. Rise Cl.: B	Amb. Temp.: + 40 to -20 °C @1000 m	kVA: H	IP 55

Mechanical data

Sound level (SPL / SWL) at 60 Hz	55.0 dB(A) / 67.0 dB(A)							Thickener	Polyurea
Octave Band Center Frequencies Hertz								Safe Stall Time Hot	26 s
	250	500	1000	2000	4000	8000	Hz	Safe Stall Time Cold	45 s
SPL@3	40.0	42.0	51.0	46.0	51.0	28.0	dB(A)	Frame material	cast iron
Moment of inertia	1.5 Lb-ft ²							Color, paint shade	Standard Paint - RAL7030
Ext Load Inertia Capability:	104.0 Lb ft ²							Coating (paint finish)	Standard Alkyed + Epoxy (C2)
Bearings								Ventilation Type	
Bearing DE NDE	6309 Z C3 S0			6309 Z C3 S0				Method of cooling	TEFC
Bearing_Type	Ball Bearing			Ball Bearing				Direction of rotation	Bidirectional
AFBMA:	45BC03JP30			45BC03JP30				Fan Material	Polypropylen ESD
Grease								VFD	CT: 4:1 VT: 20:1
Capacity	0.5 oz			0.5 oz				Space heaters	without
Grease Type:	Exxon Mobile EM							Brake:	without

Terminal box

Lead Wire Connection					9 LEAD - WYE	Terminal box position	(3) F-1, Standard Floor Mount, T. Box LHS
Voltage	L1	L1	L1	Connected together		Material of terminal box	Cast Iron
LOW	T1 T7	T2 T8	T3 T9	T4 T5 T6		Cable entry	1.25" NPT
HIGH	T1	T2	T3	T4 T7-T5 T8-T6 T9			

Notes:

I_L/I_N = locked rotor current / current nominal
M_L/M_N = locked rotor torque / torque nominal
M_d/M_N = break down torque / nominal torque

3) Value is valid only for DOL operation with motor design IC411
2) at rated power / at full load

responsible dep. DI MC LVM	technical reference	created by DT Configurator	approved by	<i>Technical data are subject to change! There may be discrepancies between software and hardware versions</i>			
	document type datasheet	document status released		customer			
	title 1LE2321-2BC11-4AA3	document number					
© Siemens AG 2022	rev. 01	creation date 2022-04-08 19:52	language en	Page 1/1			

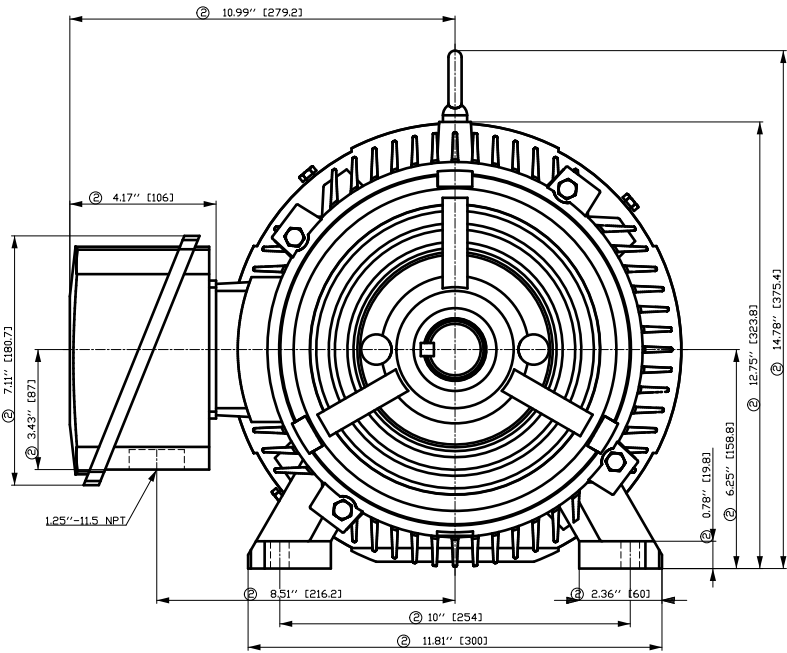

- ① Tolerances according to NEMA std.
- ② All these dimensions corresponding to assemblies and castings shall have a tolerance as per DIN standard 1686-GTB 19.
- ③ Not according to NEMA std.

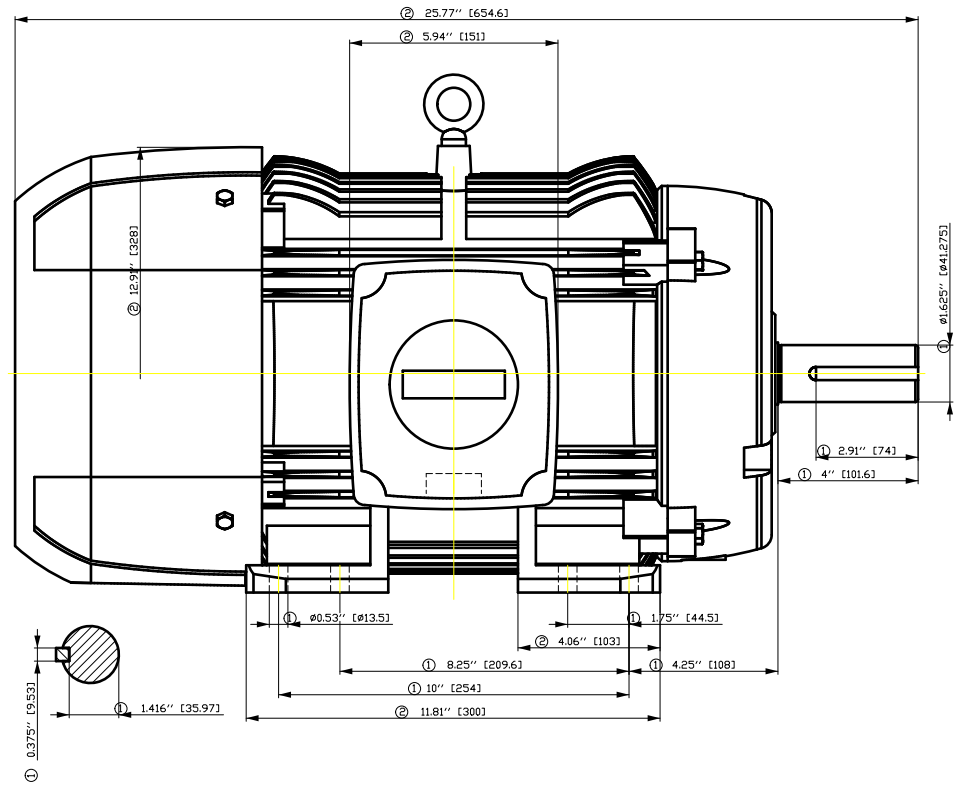

Tolerance	Surface	Material	Weight	Scale
F50G-HF-E300FFB CDEH	Author	ÖS T a : ^ & @ } *	E	
E	Creator			
	Approval			
	Department			
	Change Order	MFB	Doc Type	/
	Doc. State	I B B G	Item No	CH
	Revision	Index RS	Doc No	1st Language ^
				2nd Language a^
© Siemens AG 2018	Project No	E	Ref No	E
			Sheet	F of F

SIEMENS INDUSTRY, INC.

HP 7,5 VOLTS < 600V RPM 1200 TYPE SD100
HZ 60 PHASE 3 FRAME 254T NEMA B

TORQUE & CURRENT VS. SPEED

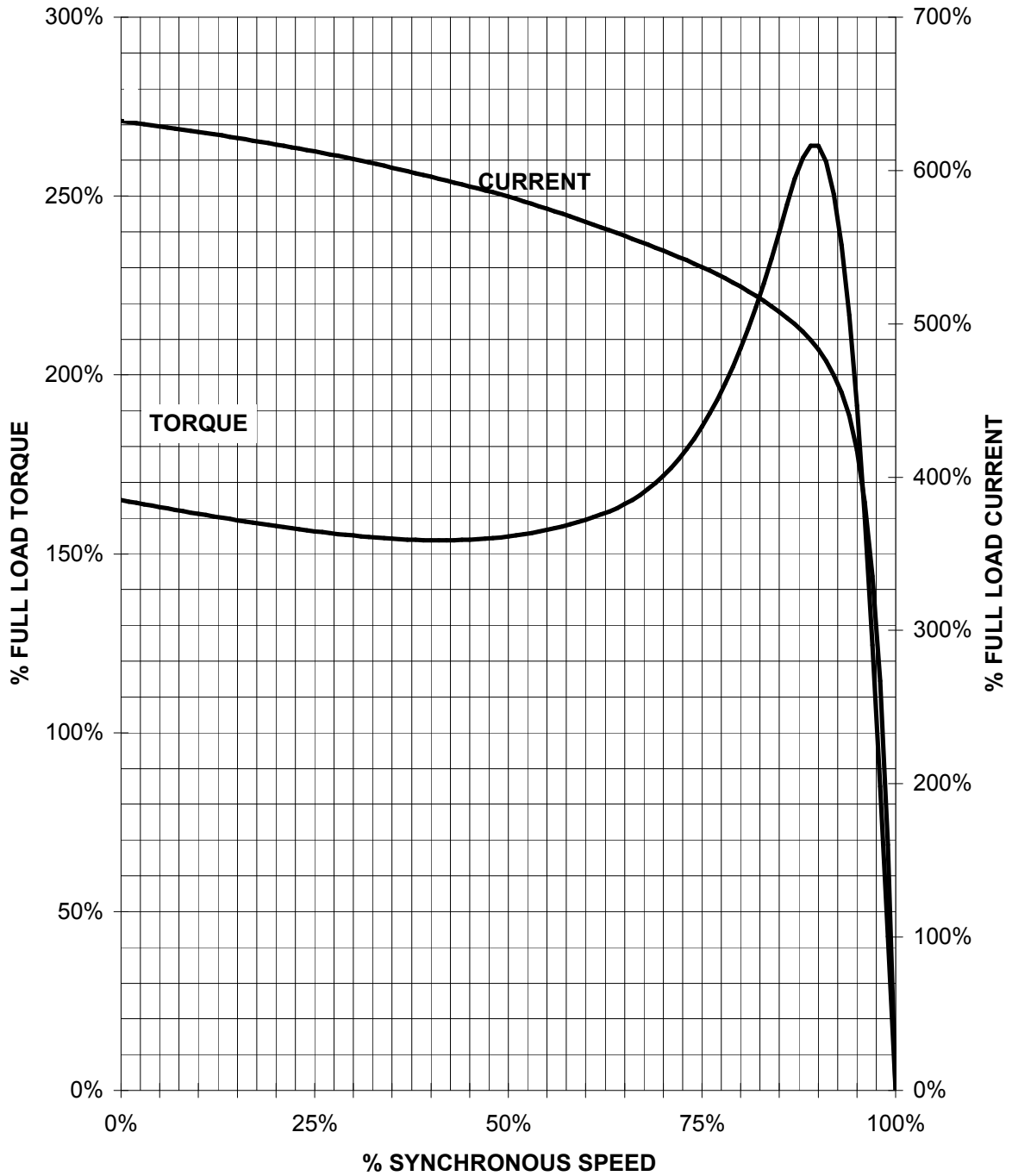

CUSTOMER: _____ ORDER#: _____

7.5 HP 1200 RPM 254T FRAME 460 VOLTS 3 PHASE NEMA DESIGN B

SIEMENS INDUSTRY, INC.
PERFORMANCE CURVE
SD100

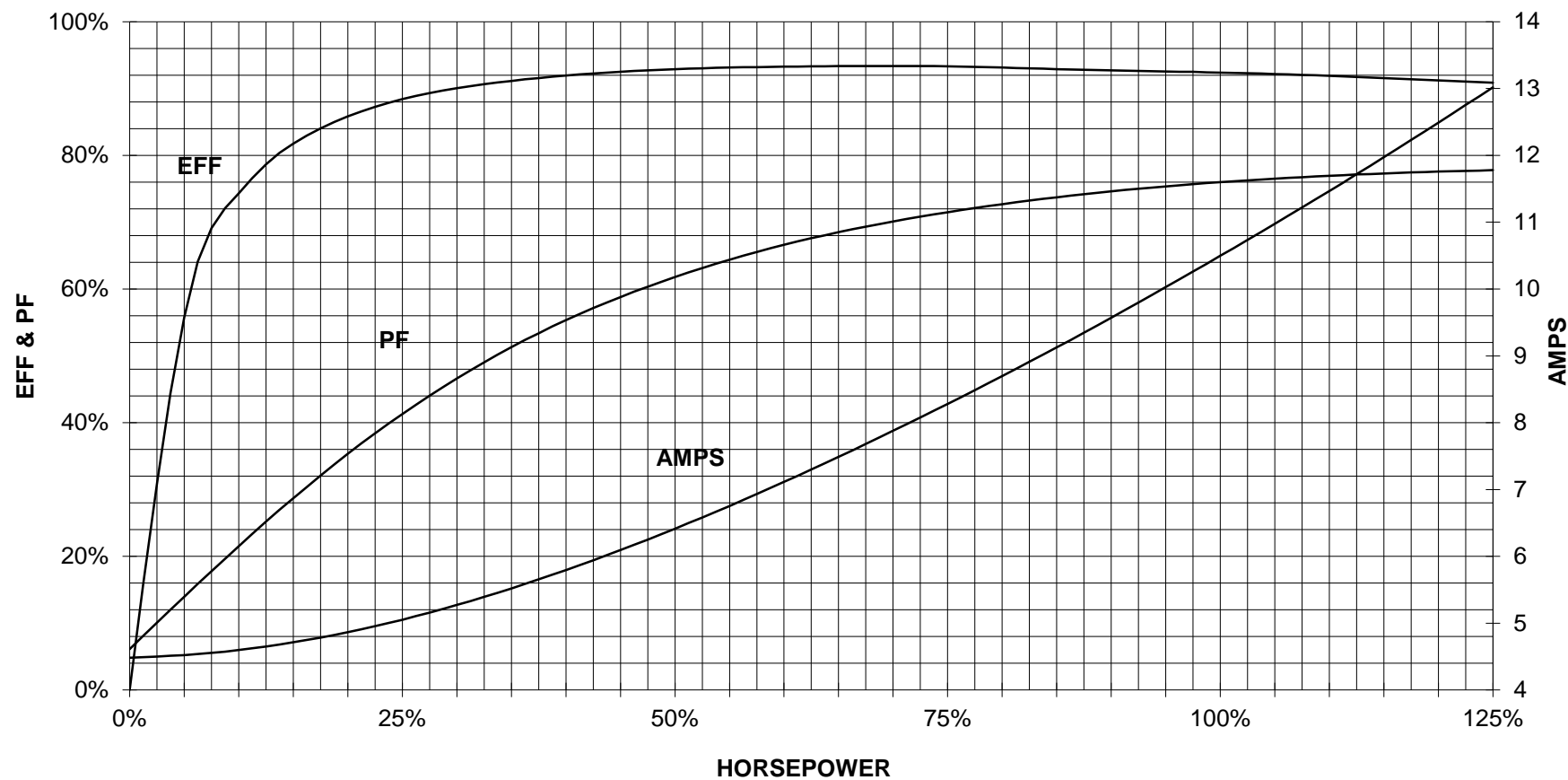

CUSTOMER _____ ORDER # _____ PO # _____

PERFORMANCE BASED ON DESIGN CALCULATIONS. SUBJECT TO CHANGE WITHOUT NOTICE.

REV. 1

Main terminal diagram

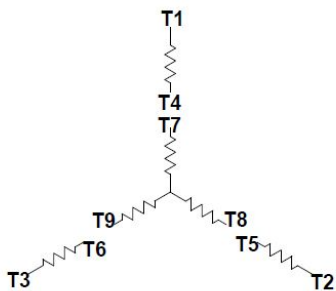

9 LEAD WYE						
Volts	LINES			CONNECTED TOGETHER	CONN.	
	L1	L2	L3			
LOW	T1 T7	T2 T6	T3 T9	T4 T5 T6	YY	
HIGH	T1	T2	T3	T4 T7-T5 T8-T6 T9	Y	

responsible dep. DI MC LVM	technical reference	created by	approved by	Project
SIEMENS	document type Wiring Diagram	document status free		customer
	title 1LE2321-2BC11-4AA3	document number		
© Siemens AG 2019	rev. 01	creation date 12/03/2019	language en	Page 1/1