

# Data sheet for three-phase Squirrel-Cage-Motors SIMOTICS

Motor type: **SD100** FS: **254T - 8p - 5 hp -**

Client order no.	Item-No.	Offer no.
Order no.	Consignment no.	Project
Remarks		

## Electrical data

Class I Division 2 Gr. A, B, C or D, T3

U [V]	$\Delta/Y$	f [Hz]	P [HP]	P [kW]	n [rpm]	I Load [Amps]					LRC	Nom. Eff Load [%]			Pwr. Factor Load [%]			Torque [lb-ft]	T <sub>A</sub> /T <sub>N</sub> LRT [%]	T <sub>k</sub> /T <sub>N</sub> BDT [%]
						4/4	3/4	1/2	0	4/4		3/4	2/4	4/4	3/4	2/4				
575	Y	60	5.00	4.00	900	6.80	6.00	5.10	4.40	26.4	86.5	87.0	85.5	61.0	54.0	43.0	30.0	153	210	

Frame Type: 254T	Type of constr.: (A) Foot mounted - End shield	Ins. Cl.: Standard Class F Insulation	Motor Prot.: (A) Without Protection	NEMA Des.: B	S.F.: 1.15
Mtr. WT: 247		Temp. Rise Cl.: B	Amb. Temp.: + 40 to -20 °C @1000 m	kVA: G	IP 55

## Mechanical data

Sound level (SPL / SWL) at 60 Hz	67.0 dB(A) / 77.0 dB(A)							Thickener	Polyurea
Octave Band Center Frequencies Hertz								Safe Stall Time Hot	65 s
	250	500	1000	2000	4000	8000	Hz	Safe Stall Time Cold	115 s
SPL@3	50.0	64.0	61.0	57.0	46.0	39.0	dB(A)	Frame material	cast iron
Moment of inertia	1.4 Lb-ft <sup>2</sup>							Color, paint shade	Standard Paint - RAL7030
Ext Load Inertia Capability:	142.0 Lb ft <sup>2</sup>							Coating (paint finish)	Standard Alkyed + Epoxy (C2)
<b>Bearings</b>								<b>Ventilation Type</b>	
Bearing DE   NDE	6309 Z C3 S0			6309 Z C3 S0				Method of cooling	TEFC
Bearing_Type	Ball Bearing			Ball Bearing				Direction of rotation	Bidirectional
AFBMA:	45BC03JP30			45BC03JP30				Fan Material	Polypropylen ESD
<b>Grease</b>								VFD	CT: 4:1 VT: 20:1
Capacity	0.5 oz			0.5 oz				Space heaters	without
Grease Type:	Exxon Mobile EM							Brake:	without

## Terminal box

Lead Wire Connection	3 LEAD - WYE				Terminal box position	(3) F-1, Standard Floor Mount, T. Box LHS
Voltage	L1	L1	L1	Connected together	Material of terminal box	Cast Iron
----	----	----	----	----	Cable entry	1.25" NPT
----	T1	T2	T3	----		

## Notes:

I<sub>L</sub>/I<sub>N</sub> = locked rotor current / current nominal  
M<sub>L</sub>/M<sub>N</sub> = locked rotor torque / torque nominal  
M<sub>B</sub>/M<sub>N</sub> = break down torque / nominal torque

3) Value is valid only for DOL operation with motor design IC411  
2) at rated power / at full load

responsible dep. DI MC LVM	technical reference	created by DT Configurator	approved by	<i>Technical data are subject to change! There may be discrepancies between software and hardware versions</i>	
	document type datasheet	document status released	customer		
	title 1LE2321-2BD11-3AA3	document number			
© Siemens AG 2022	rev. 01	creation date 2022-04-08 19:54	language en	Page 1/1	

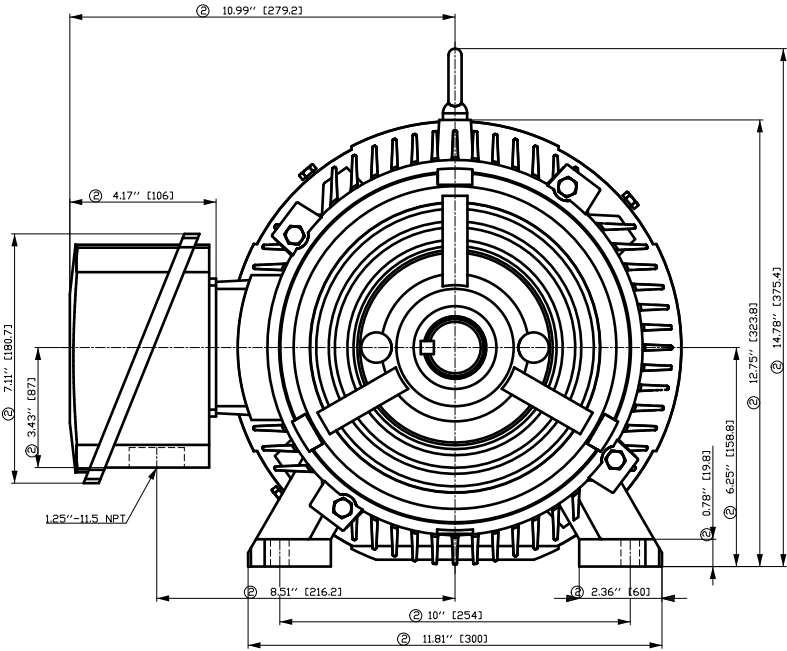

- ① Tolerances according to NEMA std.
- ② All these dimensions corresponding to assemblies and castings shall have a tolerance as per DIN standard 1686-GTB 19.
- ③ Not according to NEMA std.

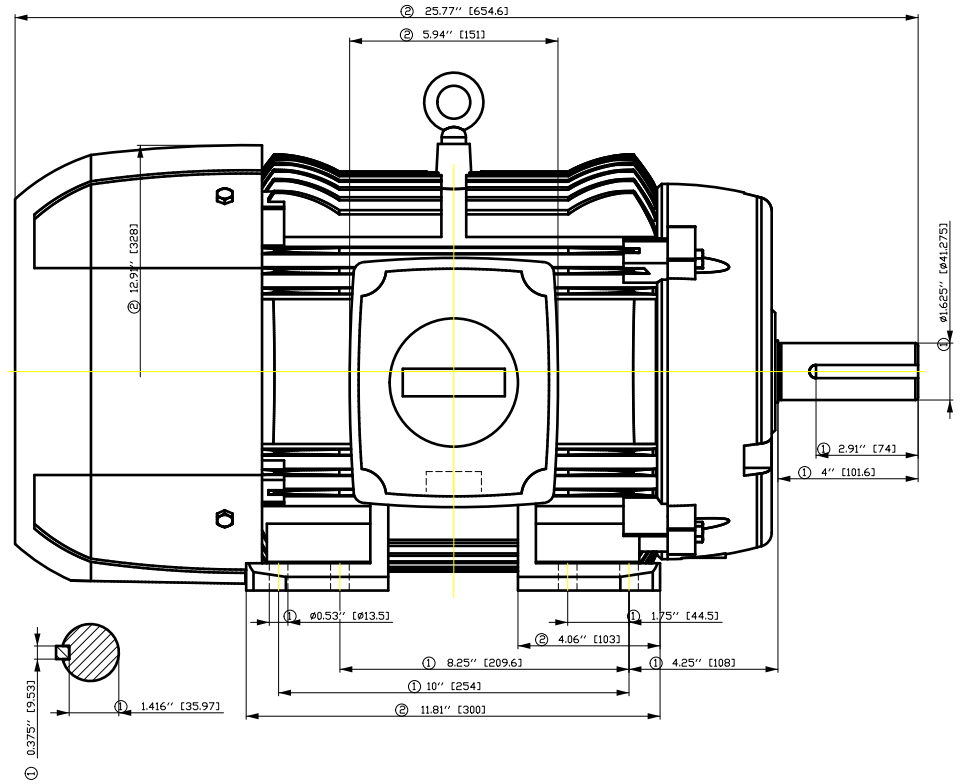

Tolerance	Surface	Material	Weight	Scale	
F5ÖG-HFEÖÖFFHÖEH	Author	ÖS Tæ: ^æ@~* MFB	E		
E	Creator				ÖVS
	Approval				
	Department				
	Change Order	MFB	Doc Type	/	
	Doc. State	I ð EGG	Item No	CH	
	Revision	Index RS	Doc No	1st Language ^ 2nd Language ä^	
	© Siemens AG 2018	Project No	E	Ref No	E
			Sheet	F of F	

# SIEMENS INDUSTRY, INC.

HP 5 VOLTS < 600V RPM 900 TYPE SD100  
HZ 60 PHASE 3 FRAME 254T NEMA B

## TORQUE & CURRENT VS. SPEED

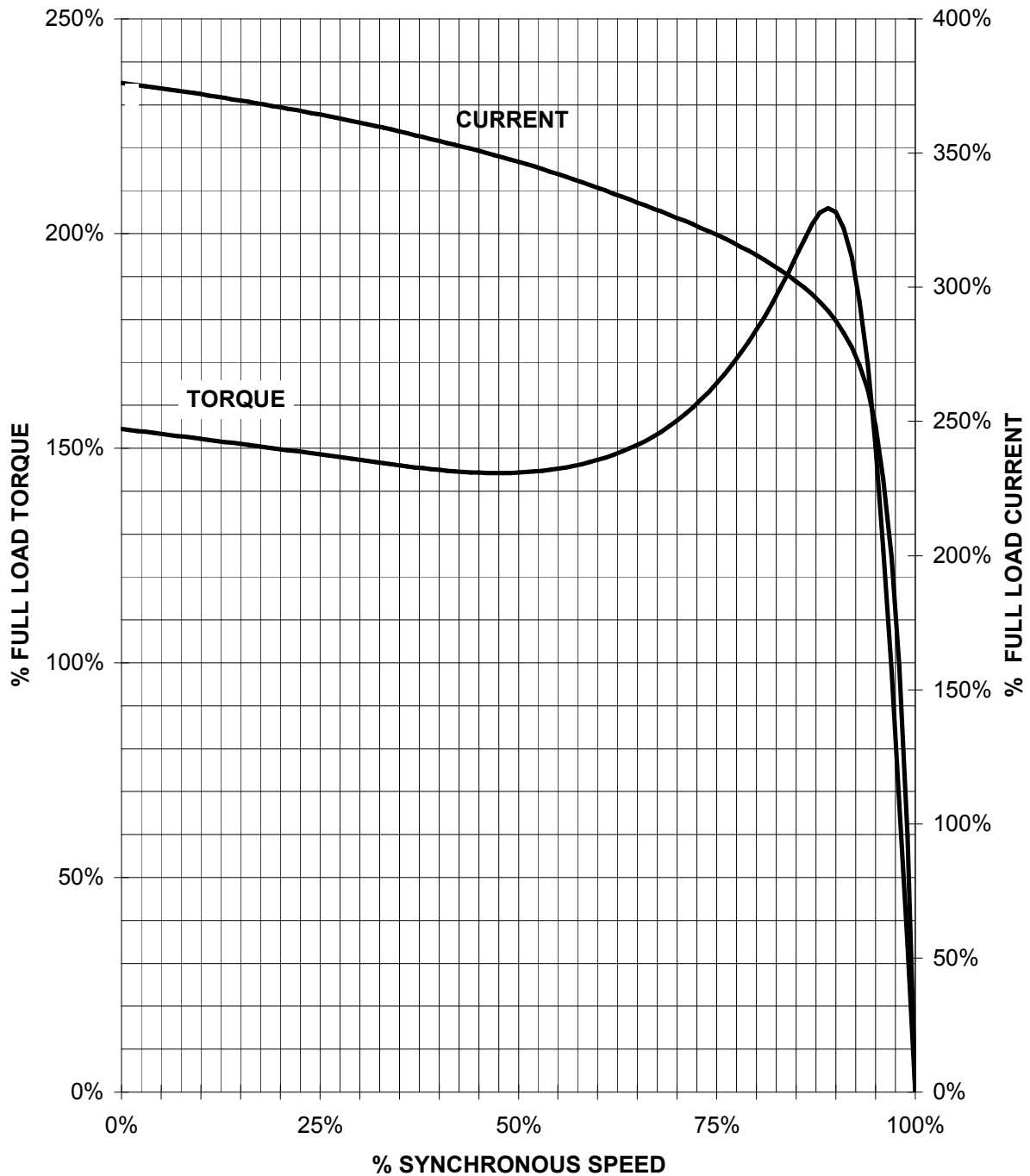

CUSTOMER: \_\_\_\_\_ ORDER#: \_\_\_\_\_

5 HP 900 RPM 254T FRAME 575 VOLTS 3 PHASE NEMA DESIGN B

**SIEMENS INDUSTRY, INC.**  
**PERFORMANCE CURVE**  
**SD100**

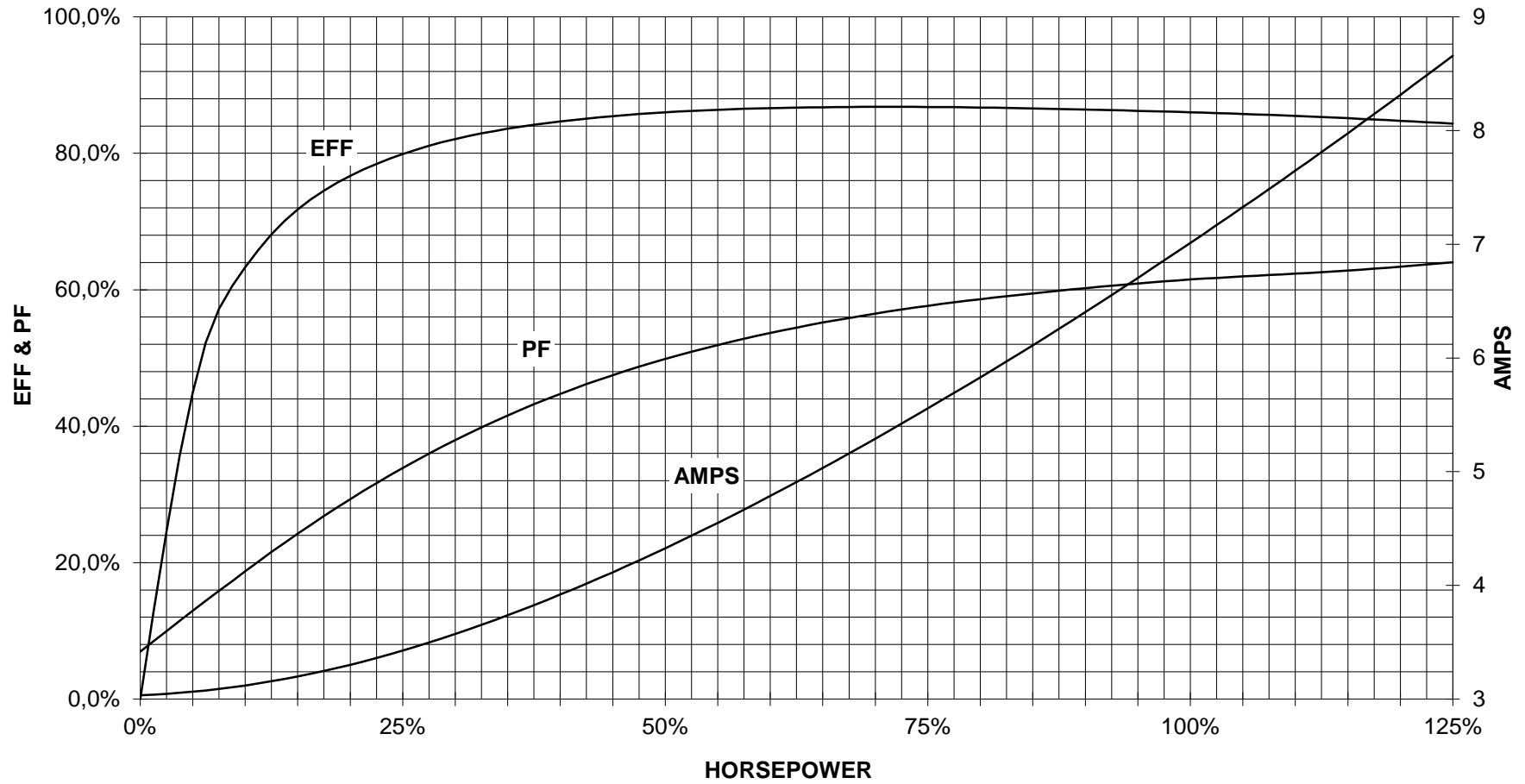

CUSTOMER \_\_\_\_\_ ORDER # \_\_\_\_\_ HORSEPOWER \_\_\_\_\_ PO # \_\_\_\_\_

PERFORMANCE BASED ON DESIGN CALCULATIONS. SUBJECT TO CHANGE WITHOUT NOTICE.

REV. 1

Main terminal diagram



3 LEAD WYE			
LINES			CONN.
L1	L2	L3	
T1	T2	T3	

responsible dep.  
DI MC LVM

technical reference

created by

approved by

Project

**SIEMENS**

document type  
Wiring Diagram

title  
1LE2321-2BD11-3AA3

document status

free

customer

document number