

Data sheet for three-phase Squirrel-Cage-Motors SIMOTICS

Motor type: SD100 FS: 286T - 6p - 20 hp -

Client order no.	Item-No.	Offer no.
Order no.	Consignment no.	Project
Remarks		

Electrical data

Class I Division 2 Gr. A, B, C or D, T3 Class II, Division 2 Gr. F or G

U [V]	Δ / Y	f [Hz]	P [HP]	P [kW]	n [rpm]	I Load [Amps]					LRC	Nom. Eff Load [%]			Pwr. Factor Load [%]			Torque [lb-ft]	T _A /T _N LRT [%]	T _k /T _N BDT [%]
						4/4	3/4	1/2	0	4/4		3/4	2/4	4/4	3/4	2/4				
575	Δ	60	20.00	15.00	1,200	21.60	17.70	14.40	10.40	116.0	91.7	92.0	91.2	76.0	69.0	57.0	89.0	149	240	

Frame Type: 286T	Type of constr.: (A) Foot mounted - End shield	Ins. Cl.: Standard Class F Insulation	Motor Prot.: (A) Without Protection	NEMA Des.: B	S.F.: 1.15
Mtr. WT: 462		Temp. Rise Cl.: B	Amb. Temp.: + 40 to -20 °C @ 1000 m	kVA: G	IP 55

Mechanical data

Sound level (SPL / SWL) at 60 Hz	61.0 dB(A) / 72.0 dB(A)							Thickener	Polyurea
Octave Band Center Frequencies Hertz									
	250	500	1000	2000	4000	8000	Hz	Safe Stall Time Hot	20 s
SPL@3	49.0	55.0	52.0	54.0	56.0	50.0	dB(A)	Safe Stall Time Cold	45 s
Moment of inertia	4.5 Lb-ft ²							Frame material	cast iron
Ext Load Inertia Capability:	262.0 Lb ft ²							Color, paint shade	Standard Paint - RAL7030
Bearings								Coating (paint finish)	Standard Alkyed + Epoxy (C2)
Bearing DE NDE	6310 Z C3 S0			6310 Z C3 S0			Ventilation Type		
Bearing_Type	Ball Bearing			Ball Bearing			Method of cooling	TEFC	
AFBMA:	50BC03JP30			50BC03JP30			Direction of rotation	Bidirectional	
Grease								Fan Material	Polypropylen ESD
Capacity	2.6 oz			2.6 oz			VFD	CT: 4:1 VT: 20:1	
Grease Type:	Exxon Mobile EM							Space heaters	without
								Brake:	without

Terminal box

Lead Wire Connection	3 LEAD - DELTA				Terminal box position	(3) F-1, Standard Floor Mount, T. Box LHS
Voltage	L1	L1	L1	Connected together	Material of terminal box	Cast Iron
----	----	----	----	----	Cable entry	1.5" NPT
----	T1	T2	T3	----		

Notes:

I_L/I_N = locked rotor current / current nominal
M_L/M_N = locked rotor torque / torque nominal
M_B/M_N = break down torque / nominal torque

3) Value is valid only for DOL operation with motor design IC411
2) at rated power I at full load

responsible dep. DI MC LVM	technical reference	created by DT Configurator	approved by	<i>Technical data are subject to change! There may be discrepancies between software and hardware versions</i>			
	document type datasheet	document status released		customer			
	title 1LE2321-2CC21-3AA3	document number					
© Siemens AG 2022	rev. 01	creation date 2022-04-08 20:39	language en	Page 1/1			

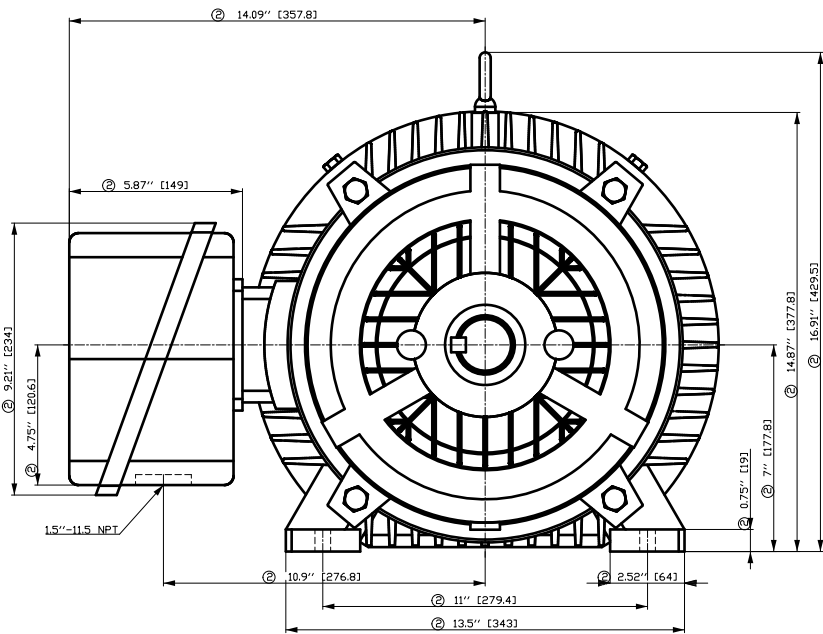

- ① Tolerances according to NEMA std.
- ② All these dimensions corresponding to assemblies and castings shall have a tolerance as per DIN standard 1686-GTB 19.
- ③ Not according to NEMA std.

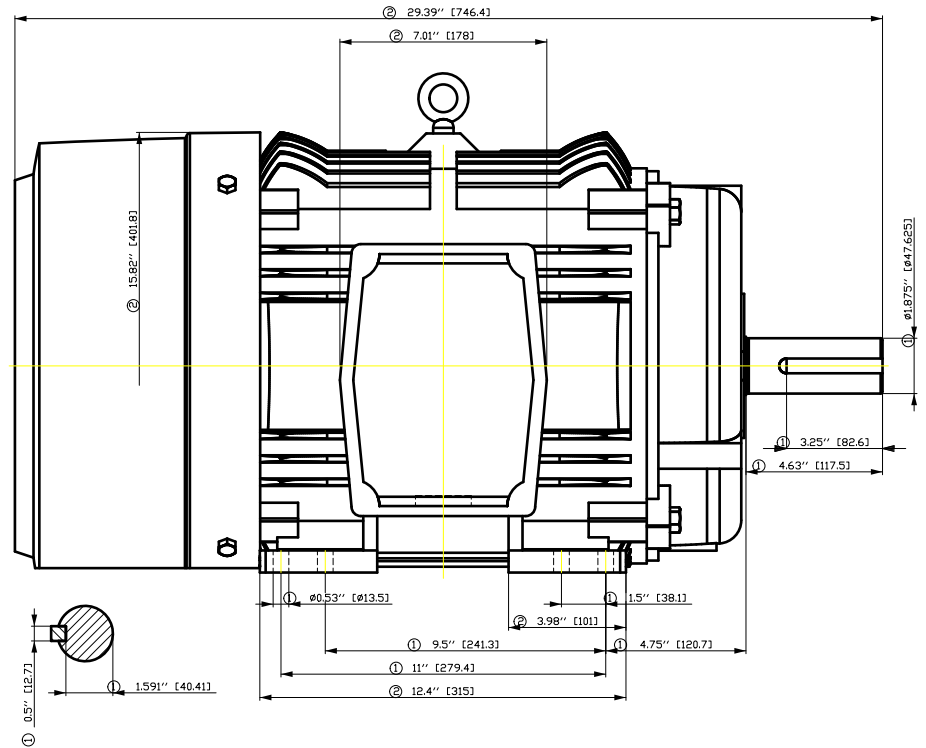

Tolerance	Surface	Material	Weight	Scale
F50GHGF00GF00H	Author	ÖS	Ä	{ }
E	Creator	T		
	Approval			
	Department			
	Change Order	MFB	Doc Type	/
SIEMENS	Doc State	I	Item No	Paper Size
© Siemens AG 2018	Revision	Index	Doc No	1st Language
	Project No	E	Ref No	2nd Language
				Sheet

SIEMENS INDUSTRY, INC.

HP 20 VOLTS < 600V RPM 1200 TYPE SD100
HZ 60 PHASE 3 FRAME 286T NEMA B

TORQUE & CURRENT VS. SPEED

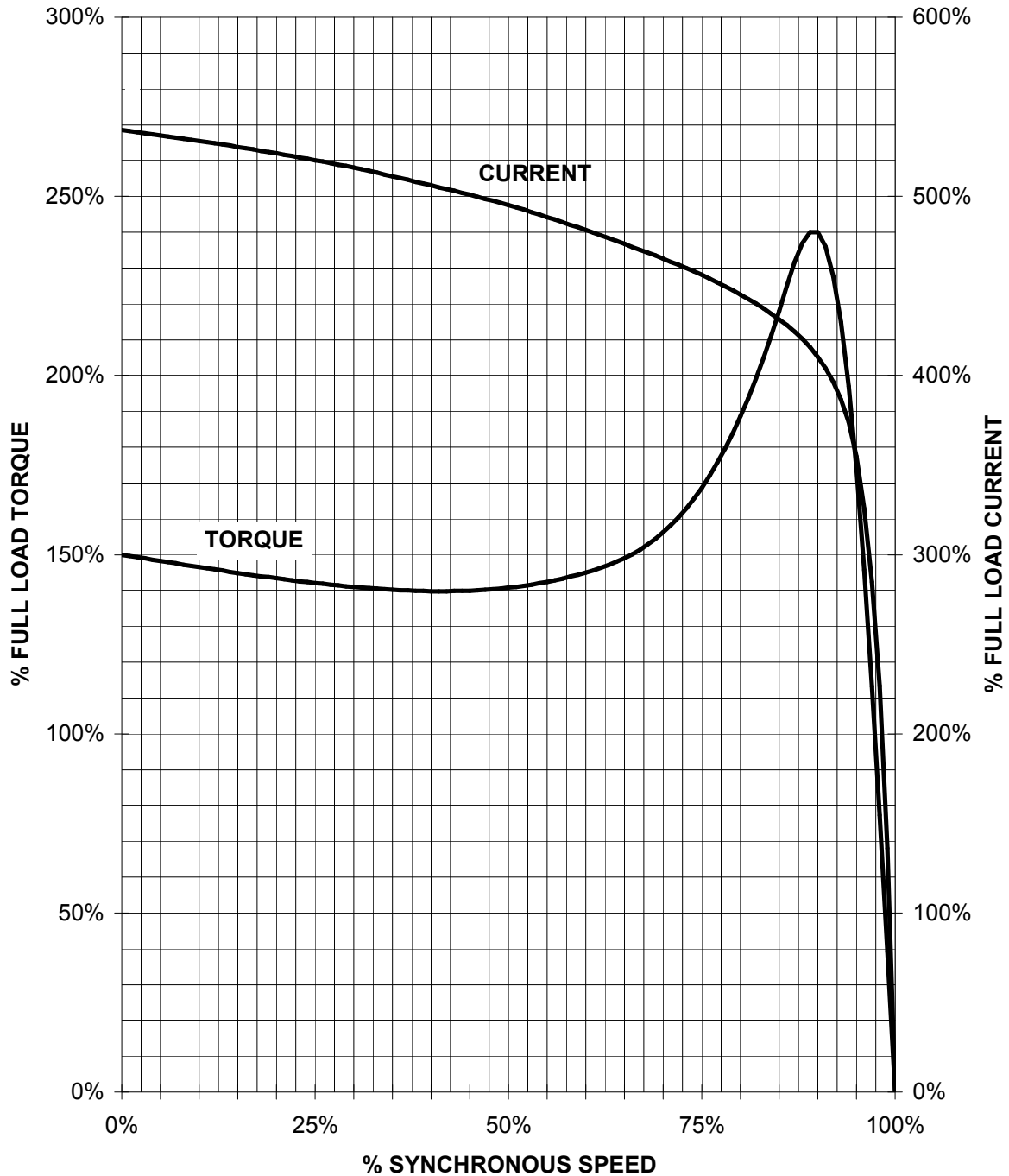

CUSTOMER: _____ ORDER#: _____

20 HP 1200 RPM 286T FRAME 575 VOLTS 3 PHASE NEMA DESIGN B

**SIEMENS INDUSTRY, INC.
PERFORMANCE CURVE
SD100**

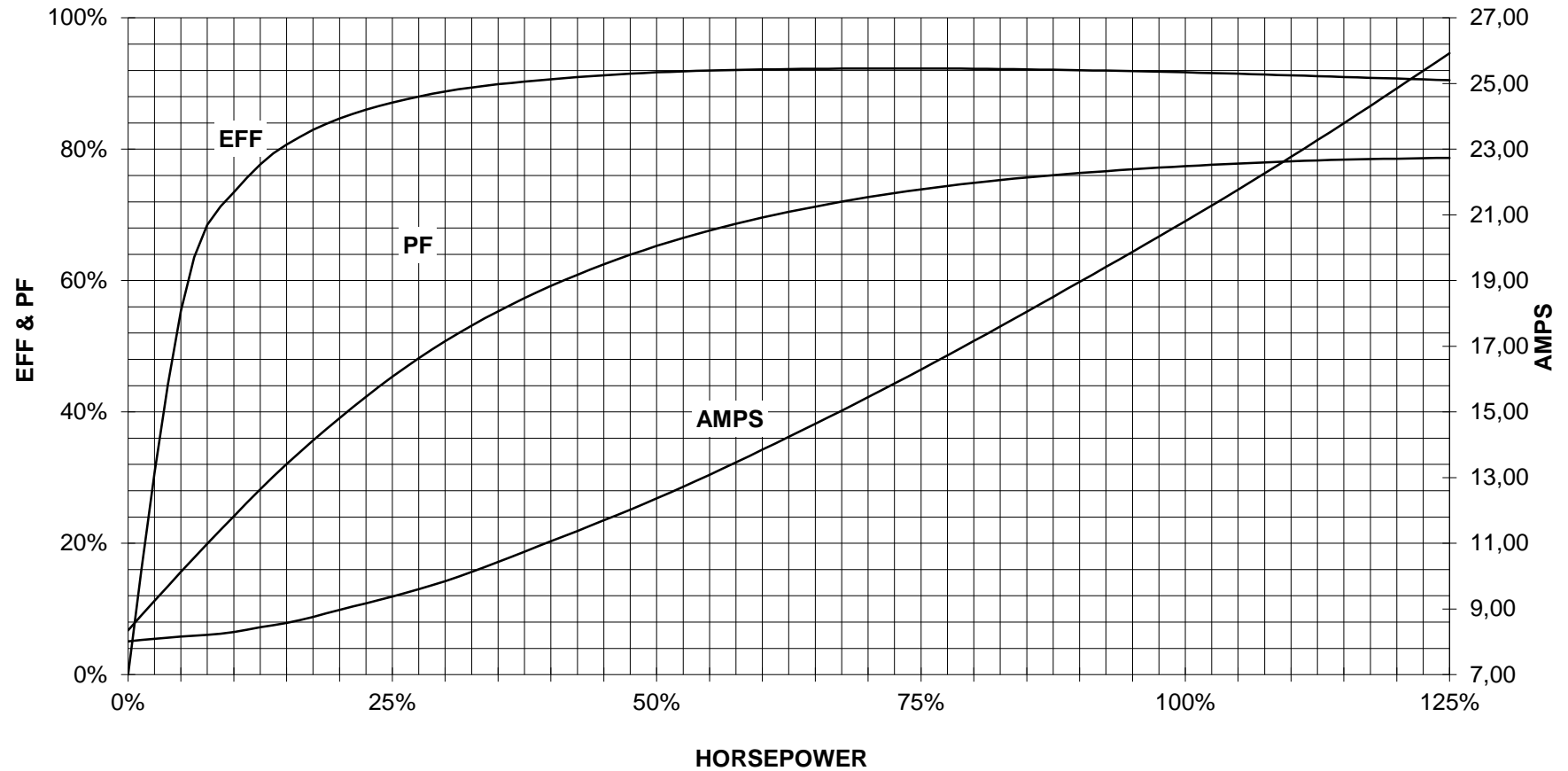

CUSTOMER: _____ ORDER #: _____

PERFORMANCE BASED ON DESIGN CALCULATIONS. SUBJECT TO CHANGE WITHOUT NOTICE.

REV. 1

Main terminal diagram



3 LEAD DELTA			
LINES			CONN.
L1	L2	L3	
T1	T2	T3	Δ

responsible dep. DI MC LVM	technical reference	created by	approved by	Project
SIEMENS	document type Wiring Diagram	document status free		customer
	title 1LE2321-2CC21-3AA3	document number		
© Siemens AG 2019	rev. 01	creation date 12/03/2019	language en	Page 1/1