

Data sheet for three-phase Squirrel-Cage-Motors SIMOTICS

Motor type: **SD100** FS: **284TS - 4p - 25 hp -**

Client order no.	Item-No.	Offer no.
Order no.	Consignment no.	Project
Remarks		

Electrical data

Class I Division 2 Gr. A, B, C or D, T3 Class II, Division 2 Gr. F or G

U [V]	Δ / Y	f [Hz]	P [HP]	P [kW]	n [rpm]	I Load [Amps]					LRC	Nom. Eff Load [%]			Pwr. Factor Load [%]			Torque [lb-ft]	T _A /T _N LRT [%]	T _k /T _N BDT [%]
						4/4	3/4	1/2	0	4/4		3/4	2/4	4/4	3/4	2/4				
575	Δ	60	25.00	18.50	1,800	24.00	18.70	14.10	8.80	146.4	93.6	94.0	93.5	84.0	80.0	71.0	74.0	180	250	
Frame Type: 284TS		Type of constr.: (A) Foot mounted - End shield				Ins. Cl.: Standard Class F Insulation		Motor Prot.: (A) Without Protection			NEMA Des.: B		S.F.: 1.15							
Mtr. WT: 445						Temp. Rise Cl.: B		Amb. Temp.: + 40 to -20 °C @1000 m			kVA: G		IP 55							

Mechanical data

Sound level (SPL / SWL) at 60 Hz	65.0 dB(A) / 76.0 dB(A)							Thickener	Polyurea
Octave Band Center Frequencies Hertz								Safe Stall Time Hot	24 s
	250	500	1000	2000	4000	8000	Hz	Safe Stall Time Cold	44 s
SPL@3	51.0	55.0	55.0	62.0	59.0	51.0	dB(A)	Frame material	cast iron
Moment of inertia	4.4 Lb-ft ²							Color, paint shade	Standard Paint - RAL7030
Ext Load Inertia Capability:	122.0 Lb ft ²							Coating (paint finish)	Standard Alkyed + Epoxy (C2)
Bearings								Ventilation Type	
Bearing DE NDE	6310 Z C3 S0			6310 Z C3 S0			Method of cooling	TEFC	
Bearing_Type	Ball Bearing			Ball Bearing			Direction of rotation	Bidirectional	
AFBMA:	50BC03JP30			50BC03JP30			Fan Material	Polypropylen ESD	
Grease								VFD	CT: 20:1 VT: 20:1
Capacity	2.6 oz			2.6 oz			Space heaters	without	
Grease Type:	Exxon Mobile EM							Brake:	without

Terminal box

Lead Wire Connection				3 LEAD - DELTA				Terminal box position	(3) F-1, Standard Floor Mount, T. Box LHS
Voltage	L1	L1	L1	Connected together				Material of terminal box	Cast Iron
----	----	----	----	----				Cable entry	1.5" NPT
----	T1	T2	T3	----					

Notes:

I_L/I_N = locked rotor current / current nominal
M_L/M_N = locked rotor torque / torque nominal
M_B/M_N = break down torque / nominal torque

3) Value is valid only for DOL operation with motor design IC411
2) at rated power / at full load

responsible dep. DI MC LVM	technical reference	created by DT Configurator	approved by	<i>Technical data are subject to change! There may be discrepancies between software and hardware versions</i>			
	document type datasheet	document status released		customer			
	title 1LE2321-2DB11-3AA3	document number					
© Siemens AG 2022	rev. 01	creation date 2022-04-08 20:44	language en	Page 1/1			

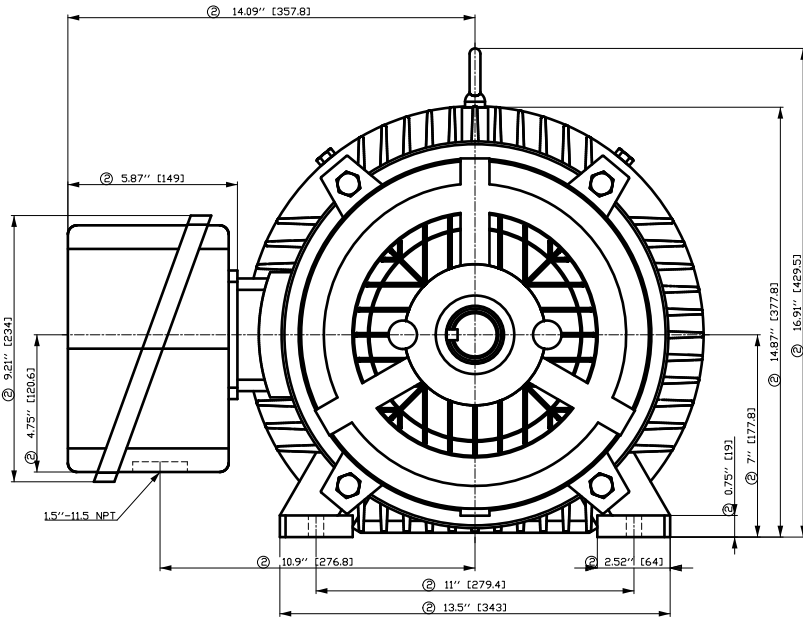

- ① Tolerances according to NEMA std.
- ② All these dimensions corresponding to assemblies and castings shall have a tolerance as per DIN standard 1686-GTB 19.
- ③ Not according to NEMA std.

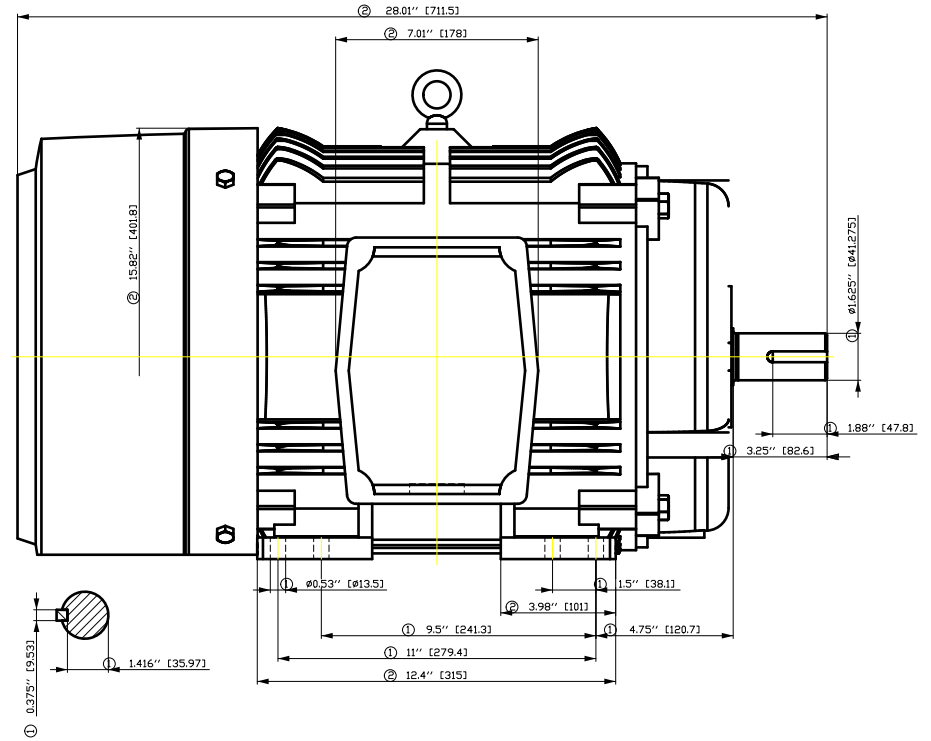

Tolerance	Surface	Material	Weight	Scale
F50GHGF00FFH00H E	Author Creator Approval Department Change Order	ÖVS Tæ: ^æ@`)*	E	{ {
SIEMENS	Doc. State	Item No	Doc Type	
	Revision	Index	Doc No	Paper Size
© Siemens AG 2018	Project No	Ref No	1st Language	2nd Language
	E	E	^	â^
			F of F	

SIEMENS INDUSTRY, INC.

HP 25 VOLTS < 600V RPM 1800 TYPE SD100
HZ 60 PHASE 3 FRAME 284TS NEMA B

TORQUE & CURRENT VS. SPEED

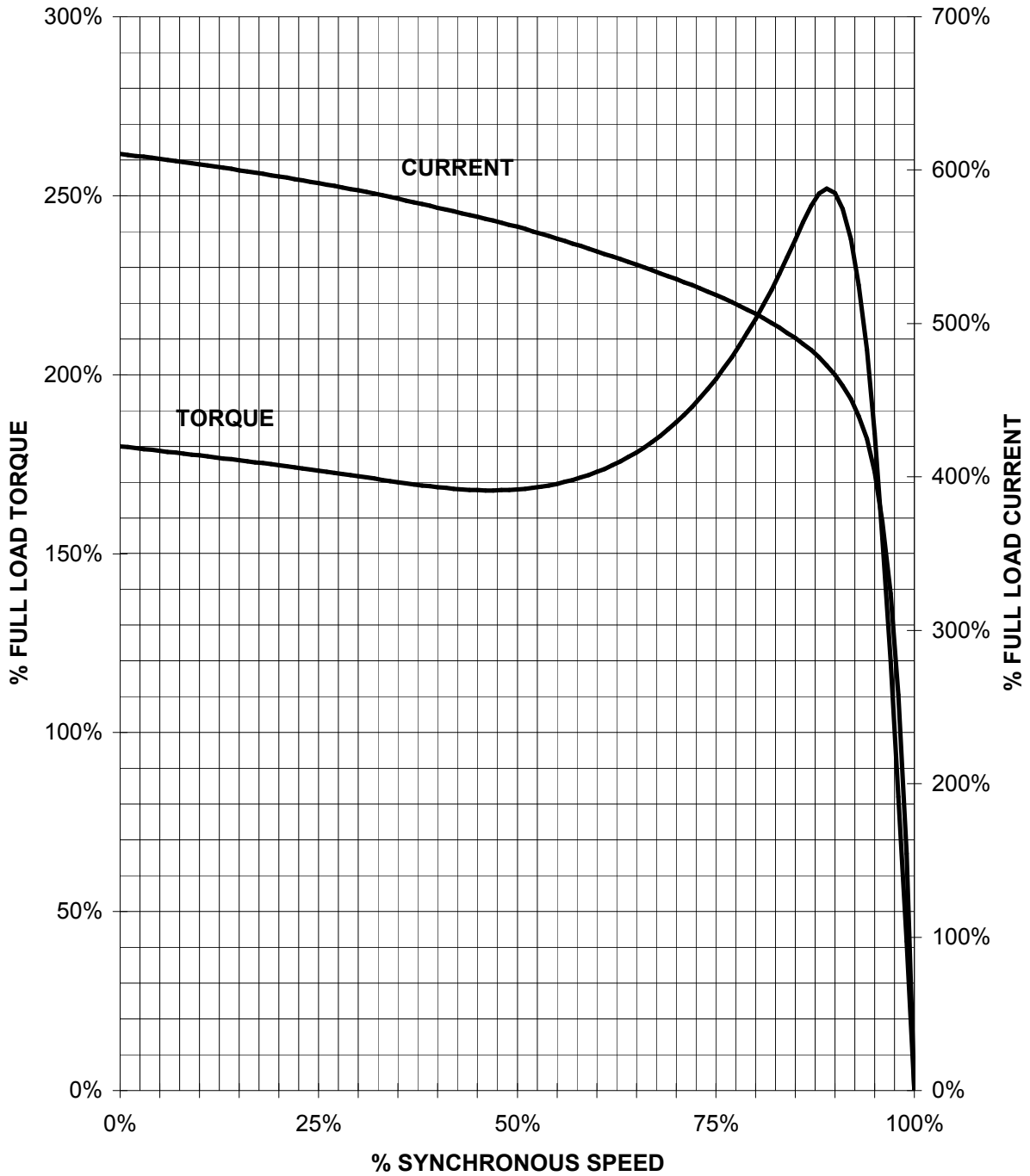

CUSTOMER: _____ ORDER#: _____

25 HP 1800 RPM 284TS FRAME 575 VOLTS 3 PHASE NEMA DESIGN B

SIEMENS INDUSTRY, INC.
PERFORMANCE CURVE
SD100

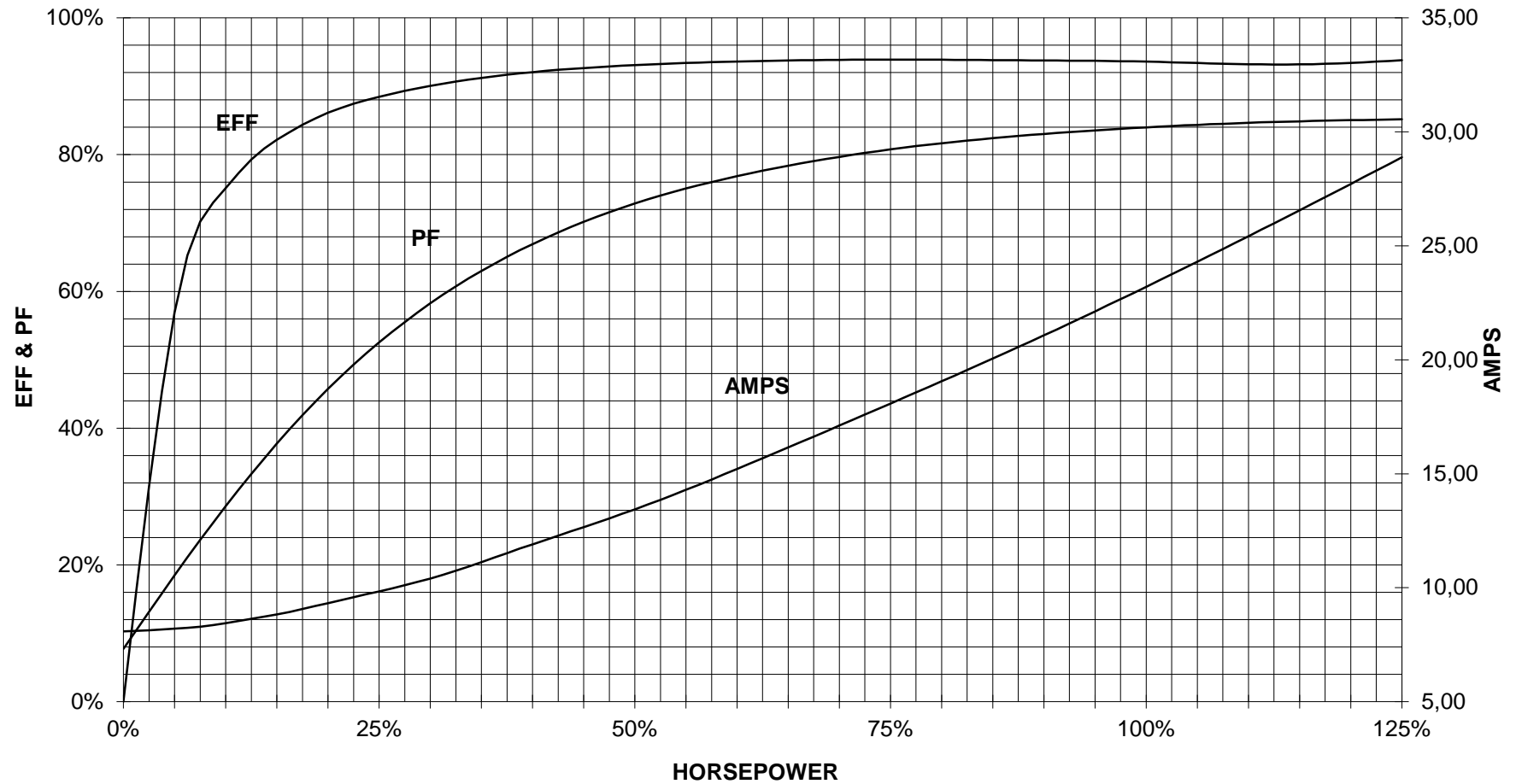

CUSTOMER: _____ ORDER #: _____

PERFORMANCE BASED ON DESIGN CALCULATIONS. SUBJECT TO CHANGE WITHOUT NOTICE.

REV. 1

Main terminal diagram

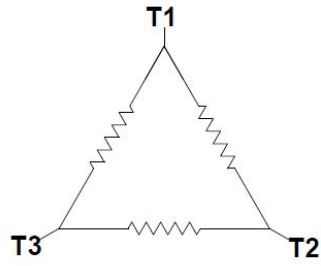

3 LEAD DELTA			
LINES			CONN.
L1	L2	L3	
T1	T2	T3	Δ

responsible dep.
DI MC LVM

technical reference

created by

approved by

Project

SIEMENS

document type
Wiring Diagram

title
1LE2321-2DB11-3AA3

document status
free

document number

customer