

Data sheet for three-phase Squirrel-Cage-Motors SIMOTICS

Motor type: **SD100** FS: **326TS - 2p - 50 hp -**

Client order no.	Item-No.	Offer no.
Order no.	Consignment no.	Project

Remarks

Electrical data

Class I Division 2 Gr. A, B, C or D, T3 Class II, Division 2 Gr. F or G

U [V]	Δ / Y	f [Hz]	P [HP]	P [kW]	n [rpm]	I Load [Amps]					LRC	Nom. Eff Load [%]			Pwr. Factor Load [%]			Torque [lb-ft]	T _A /T _N LRT [%]	T _k /T _N BDT [%]
						4/4	3/4	1/2	0			4/4	3/4	2/4	4/4	3/4	2/4			
460	Δ	60	50.00	37.00	3,600	55.00	41.90	30.40	15.00	363.0	93.6	94.1	93.8	91.0	89.0	82.0	74.0	150	250	
400	Δ	50	40.00		2,968	54.80	44.70	36.20	27.90	336.0	93.3	93.8	93.5	87.2	81.9	70.8	70.9	180	285	

Frame Type: 326TS	Type of constr.: (A) Foot mounted - End shield	Ins. Cl.: Standard Class F Insulation	Motor Prot.: (A) Without Protection	NEMA Des.: B	S.F.: 1.15
Mtr. WT: 573		Temp. Rise Cl.: B	Amb. Temp.: + 40 to -20 °C @1000 m	kVA: G	IP 55

Mechanical data

Sound level (SPL / SWL) at 60 Hz	77.0 dB(A) / 87.0 dB(A)							Thickener	Polyurea
Octave Band Center Frequencies Hertz								Safe Stall Time Hot	18 s
	250	500	1000	2000	4000	8000	Hz	Safe Stall Time Cold	37 s
SPL@3	56.0	68.0	68.0	70.0	74.0	54.0	dB(A)	Frame material	cast iron
Moment of inertia	3.6 Lb-ft ²							Color, paint shade	Standard Paint - RAL7030
Ext Load Inertia Capability:	49.0 Lb ft ²							Coating (paint finish)	Standard Alkyed + Epoxy (C2)
Bearings								Ventilation Type	
Bearing DE NDE	6312 Z C3 S0			6312 Z C3 S0			Method of cooling	TEFC	
Bearing_Type	Ball Bearing			Ball Bearing			Direction of rotation	Bidirectional	
AFBMA:	60BC03JP30			60BC03JP30			Fan Material	Polypropylen ESD	
Grease								VFD	CT: 4:1 VT: 20:1
Capacity	5.5 oz			5.5 oz			Space heaters	without	
Grease Type:	Exxon Mobile EM							Brake:	without

Terminal box

Lead Wire Connection	3 LEAD - DELTA				Terminal box position	(3) F-1, Standard Floor Mount, T. Box LHS	
Voltage	L1	L1	L1	Connected together	Material of terminal box	Cast Iron	
----	----	----	----	----	Cable entry	2" NPT	
----	T1	T2	T3	----			

Notes:

I_L/I_N = locked rotor current / current nominal
M_L/M_N = locked rotor torque / torque nominal
M_d/M_N = break down torque / nominal torque

3) Value is valid only for DOL operation with motor design IC411
2) at rated power / at full load

responsible dep. DI MC LVM	technical reference	created by DT Configurator	approved by	<i>Technical data are subject to change! There may be discrepancies between software and hardware versions</i>
-------------------------------	---------------------	-------------------------------	-------------	----------------------------------------------------------------------------------------------------------------

	document type datasheet	document status released	customer	
	title 1LE2321-3BA21-2AA3	document number		
© Siemens AG 2022	rev. 01	creation date 2022-04-08 21:24	language en	Page 1/1

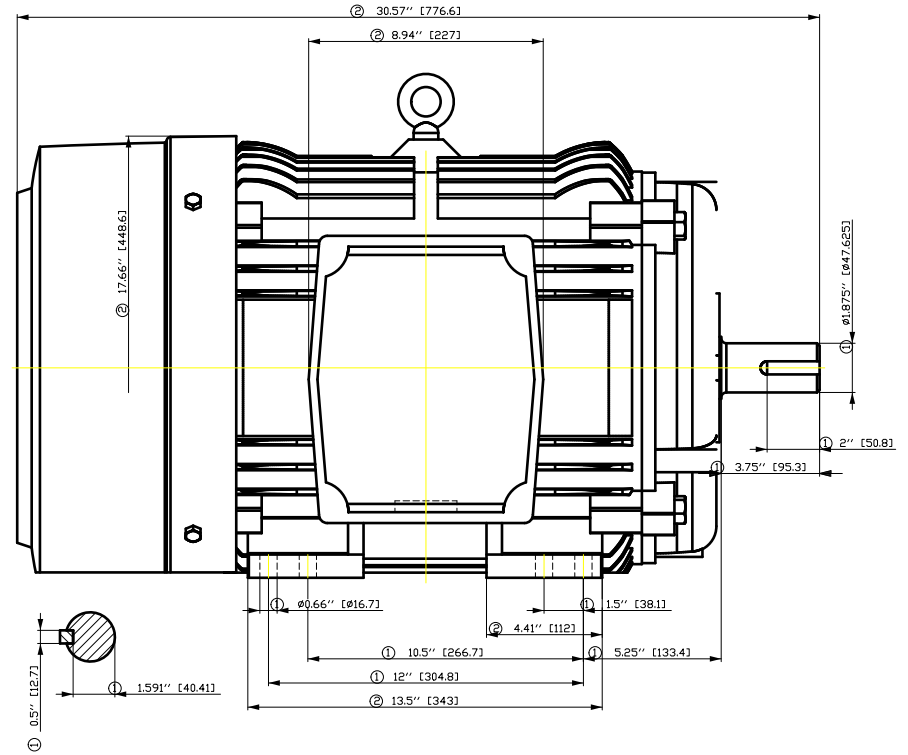
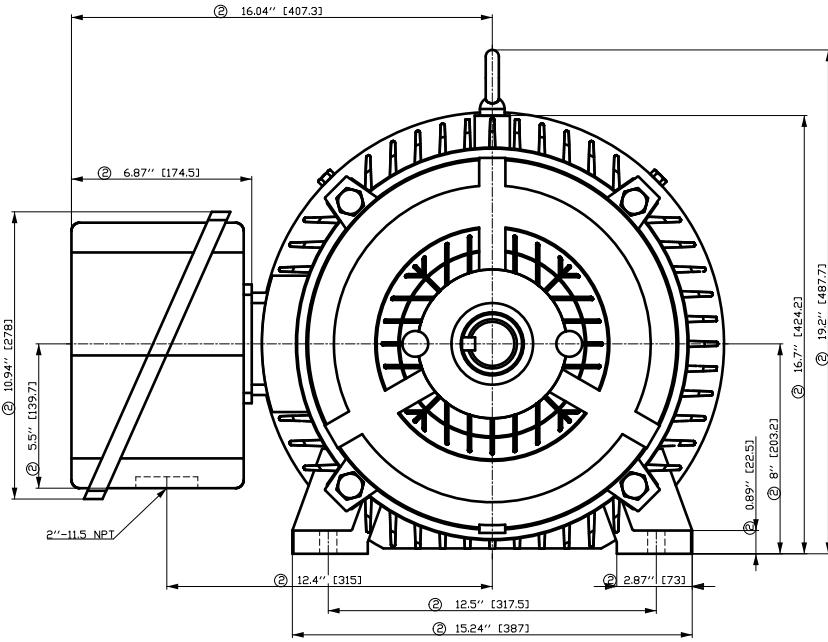

- ① Tolerances according to NEMA std.
- ② All these dimensions corresponding to assemblies and castings shall have a tolerance as per DIN standard 1686-GTB 19.
- ③ Not according to NEMA std.

Tolerance	Surface	Material	Weight	Scale
F50G-GE-006-E30EH E	Author Creator Approval Department Change Order	ÖVS Tæ: ^æ@ }*	E	{ {
SIEMENS	Doc. State Revision	MLFB Item No Doc No	Doc Type Paper Size	CH ^ } â ^
© Siemens AG 2018	Index Project No	RS E	Ref No	E F of F

SIEMENS INDUSTRY, INC.

HP 50 VOLTS < 600V RPM 3600 TYPE SD100
HZ 60 PHASE 3 FRAME 326TS NEMA B

TORQUE & CURRENT VS. SPEED

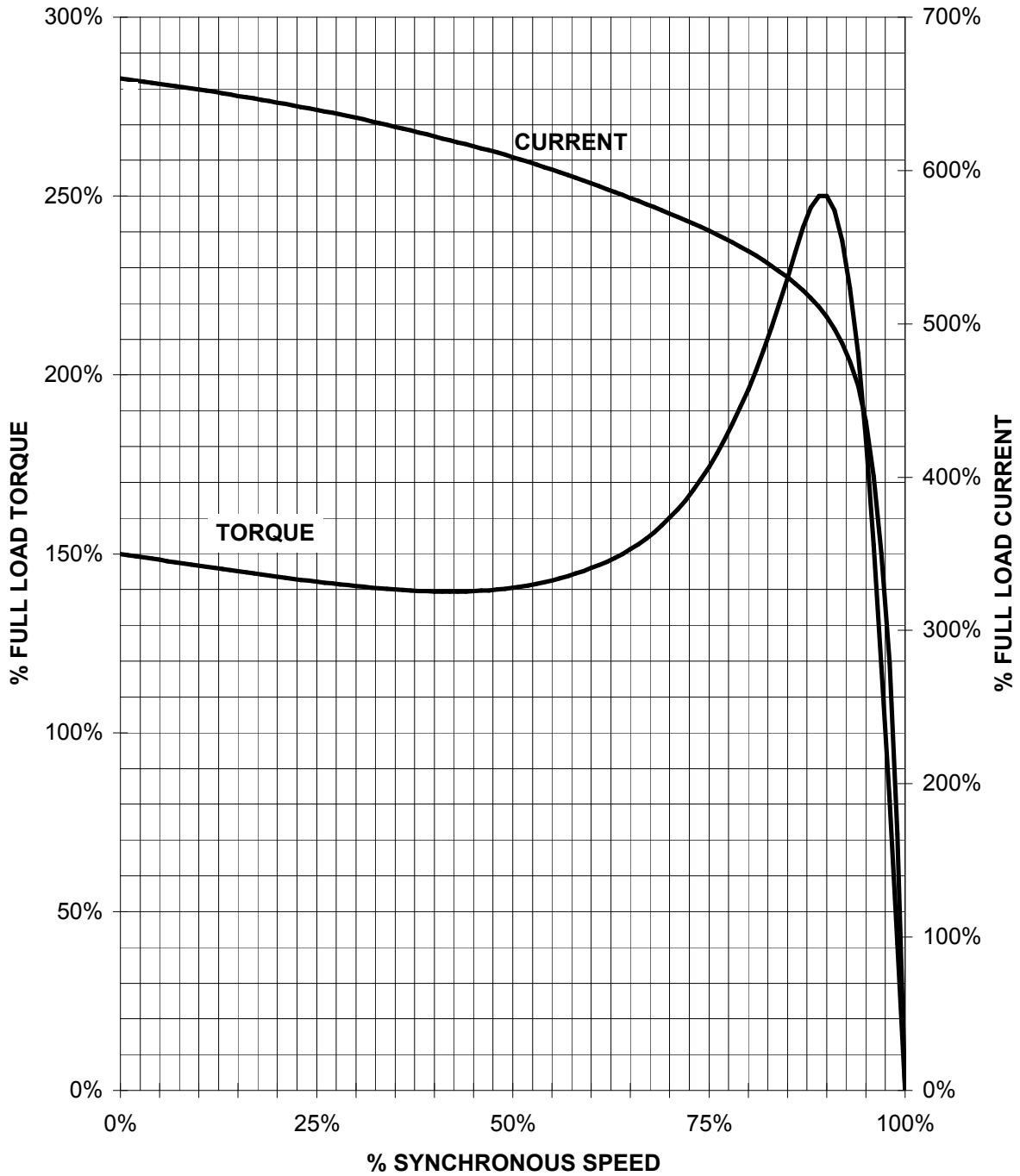

CUSTOMER: _____ ORDER#: _____

50 HP 3600 RPM 326TS FRAME 460 VOLTS 3 PHASE NEMA DESIGN B

SIEMENS INDUSTRY, INC.
PERFORMANCE CURVE
SD100

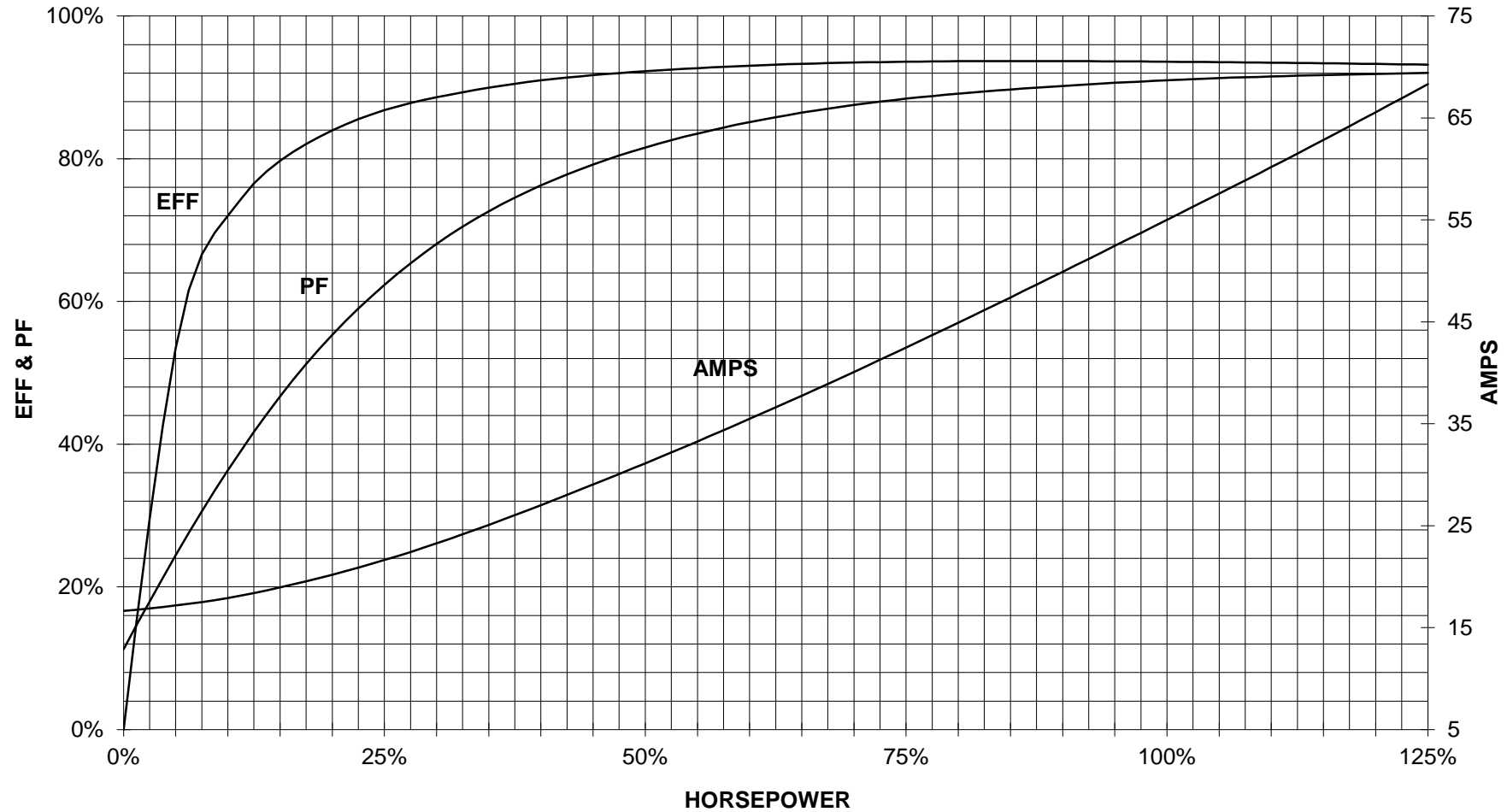

CUSTOMER: _____ ORDER # _____ PO # _____

PERFORMANCE BASED ON DESIGN CALCULATIONS. SUBJECT TO CHANGE WITHOUT NOTICE.

REV. 1

Main terminal diagram



3 LEAD DELTA			
LINES			CONN.
L1	L2	L3	
T1	T2	T3	Δ

responsible dep. DI MC LVM	technical reference	created by	approved by	Project		
	document type Wiring Diagram		document status free		customer	
	title 1LE2321-3BA21-2AA3		document number			
© Siemens AG 2019			rev. 01	creation date 12/03/2019	language en	Page 1/1