

Data sheet for three-phase Squirrel-Cage-Motors SIMOTICS

Motor type: **SD100** FS: **365T - 4p - 75 hp -**

Client order no.	Item-No.	Offer no.
Order no.	Consignment no.	Project
Remarks		

Electrical data

Class I Division 2 Gr. A, B, C or D, T3 Class II, Division 2 Gr. F or G

U [V]	Δ / Y	f [Hz]	P [HP]	P [kW]	n [rpm]	I Load [Amps]					LRC	Nom. Eff Load [%]			Pwr. Factor Load [%]			Torque [lb-ft]	T _A /T _N LRT [%]	T _k /T _N BDT [%]
						4/4	3/4	1/2	0	4/4		3/4	2/4	4/4	3/4	2/4				
460	Δ	60	75.00	55.00	1,800	85.00	64.70	47.10	25.00	543.0	95.4	95.8	95.6	87.0	85.0	78.0	221.0	180	240	
400	Δ	50	60.00		1,486	81.50	62.70	46.98	29.10	585.0	94.2	94.6	94.1	84.0	81.7	73.0	213.3	238	148	

Frame Type: 365T	Type of constr.: (A) Foot mounted - End shield	Ins. Cl.: Standard Class F Insulation	Motor Prot.: (A) Without Protection	NEMA Des.: B	S.F.: 1.15
Mtr. WT: 1,000		Temp. Rise Cl.: B	Amb. Temp.: + 40 to -20 °C @1000 m	kVA: G	IP 55

Mechanical data

Sound level (SPL / SWL) at 60 Hz	64.0 dB(A) / 75.0 dB(A)							Thickener	Polyurea	
Octave Band Center Frequencies Hertz								Safe Stall Time Hot	25 s	
	250	500	1000	2000	4000	8000	Hz	Safe Stall Time Cold	35 s	
SPL@3	52.0	56.0	58.0	58.0	57.0	52.0	dB(A)	Frame material	cast iron	
Moment of inertia	19.7 Lb-ft ²							Color, paint shade	Standard Paint - RAL7030	
Ext Load Inertia Capability:	338.0 Lb ft ²							Coating (paint finish)	Standard Alkyed + Epoxy (C2)	
Bearings								Ventilation Type		
Bearing DE NDE	6314 Z C3 S0			6314 Z C3 S0			Method of cooling	TEFC		
Bearing_Type	Ball Bearing			Ball Bearing			Direction of rotation	Bidirectional		
AFBMA:	70BC03JP30			70BC03JP30			Fan Material	Polypropylen ESD		
Grease								VFD	CT: 20:1 VT: 20:1	
Capacity	7.5 oz			7.5 oz			Space heaters	without		
Grease Type:	Exxon Mobile EM							Brake:	without	

Terminal box

Lead Wire Connection	3 LEAD - DELTA				Terminal box position	(3) F-1, Standard Floor Mount, T. Box LHS
Voltage	L1	L1	L1	Connected together	Material of terminal box	Cast Iron
----	----	----	----	----	Cable entry	3" NPT
----	T1	T2	T3	----		

Notes:

I_L/I_N = locked rotor current / current nominal
M_L/M_N = locked rotor torque / torque nominal
M_d/M_N = break down torque / nominal torque

3) Value is valid only for DOL operation with motor design IC411
2) at rated power / at full load

responsible dep. DI MC LVM	technical reference	created by DT Configurator	approved by	<i>Technical data are subject to change! There may be discrepancies between software and hardware versions</i>	
	document type datasheet	document status released	customer		
	title 1LE2321-3CB21-2AA3	document number			
© Siemens AG 2022	rev. 01	creation date 2022-04-08 21:59	language en	Page 1/1	

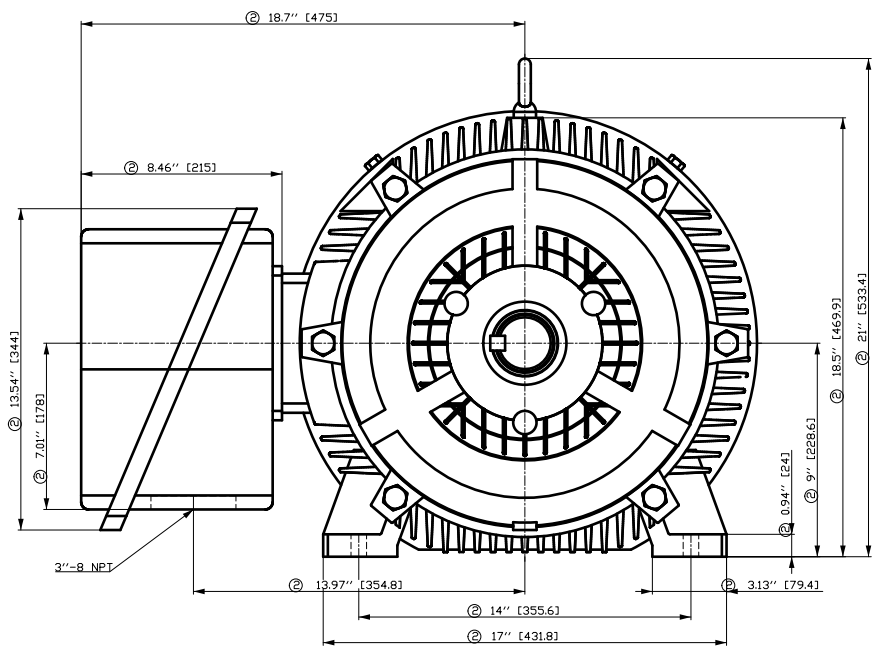

- ① Tolerances according to NEMA std.
- ② All these dimensions corresponding to assemblies and castings shall have a tolerance as per DIN standard 1686-GTB 19.
- ③ Not according to NEMA std.

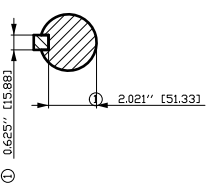
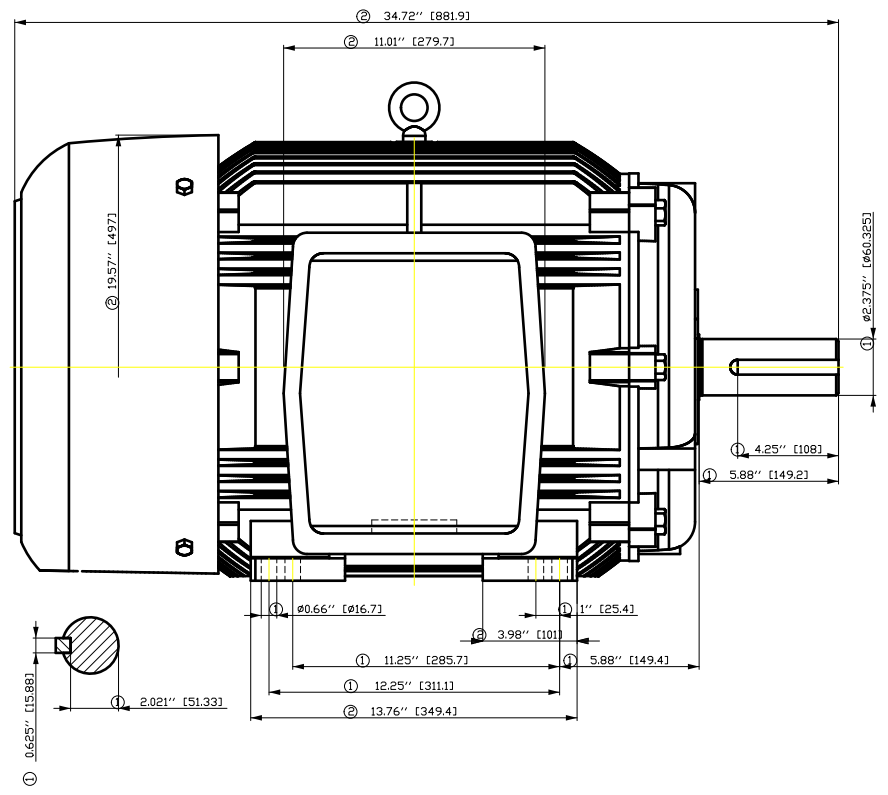

Tolerance	Surface	Material	Weight	Scale
F50G H7/f6 H6/g6	Author	ÖS T a : ^ & @ } *	E	
E	Creator			
	Approval			
	Department			
	Change Order	MFB	Doc Type	/
	Doc. State	I 0000	Item No	Paper Size
	Revision	Index RS	Doc No	1st Language
				2nd Language
© Siemens AG 2018	Project No	E	Ref No	E
				Sheet F of F

SIEMENS INDUSTRY, INC.

HP 75 VOLTS < 600V RPM 1800 TYPE SD100
HZ 60 PHASE 3 FRAME 365T NEMA B

TORQUE & CURRENT VS. SPEED

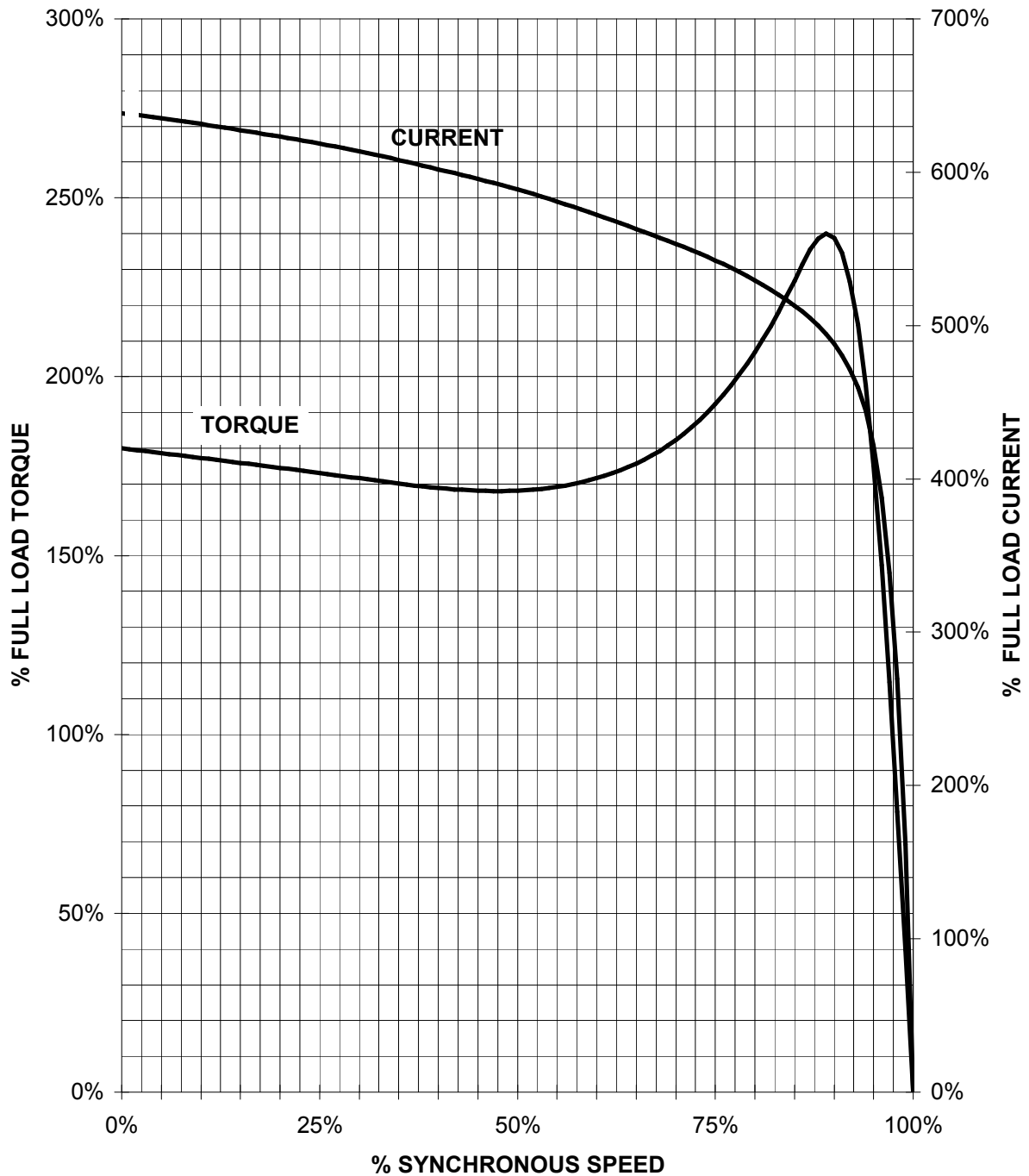

CUSTOMER: _____ ORDER#: _____

75 HP 1800 RPM 365T FRAME 460 VOLTS 3 PHASE NEMA DESIGN B

SIEMENS INDUSTRY, INC.
PERFORMANCE CURVE
SD100

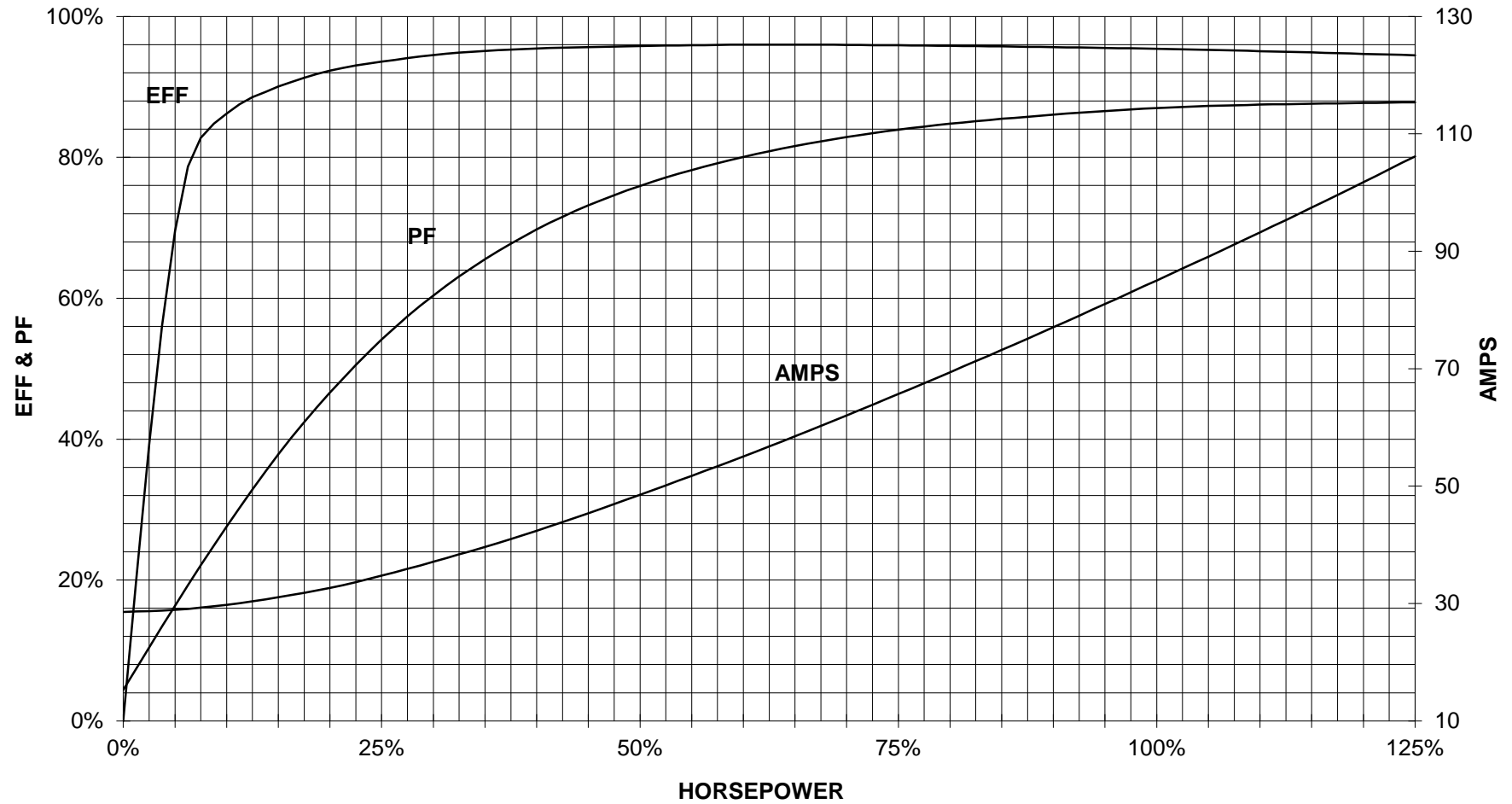

CUSTOMER _____ ORDER # _____ PO # _____

PERFORMANCE BASED ON DESIGN CALCULATIONS. SUBJECT TO CHANGE WITHOUT NOTICE.
REV. 1

Main terminal diagram



3 LEAD DELTA			
LINES			CONN.
L1	L2	L3	
T1	T2	T3	Δ

responsible dep. DI MC LVM	technical reference	created by	approved by	Project
SIEMENS	document type Wiring Diagram	document status free		customer
	title 1LE2321-3CB21-2AA3	document number		
© Siemens AG 2019		rev. 01	creation date 12/03/2019	language en Page 1/1