

Data sheet for three-phase Squirrel-Cage-Motors SIMOTICS

Motor type: **SD100** FS: **364TS - 4p - 60 hp -**

Client order no.	Item-No.	Offer no.
Order no.	Consignment no.	Project
Remarks		

Electrical data

Class I Division 2 Gr. A, B, C or D, T3 Class II, Division 2 Gr. F or G

U [V]	Δ / Y	f [Hz]	P [HP]	P [kW]	n [rpm]	I Load [Amps]					LRC	Nom. Eff Load [%]			Pwr. Factor Load [%]			Torque [lb-ft]	T _A /T _N LRT [%]	T _k /T _N BDT [%]
						4/4	3/4	1/2	0	4/4		3/4	2/4	4/4	3/4	2/4				
460	Δ	60	60.00	45.00	1,800	68.00	52.00	38.30	19.00	435.0	95.0	95.4	95.2	87.0	85.0	77.0	177.0	180	240	
400	Δ	50	50.00		1,486	67.00	52.80	40.30	26.50	485.2	93.9	94.3	94.0	84.5	80.1	70.1	176.7	238	302	

Frame Type: 364TS	Type of constr.: (A) Foot mounted - End shield	Ins. Cl.: Standard Class F Insulation	Motor Prot.: (A) Without Protection	NEMA Des.: B	S.F.: 1.15
Mtr. WT: 936		Temp. Rise Cl.: B	Amb. Temp.: + 40 to -20 °C @1000 m	kVA: G	IP 55

Mechanical data

Sound level (SPL / SWL) at 60 Hz	64.0 dB(A) / 75.0 dB(A)							Thickener	Polyurea
Octave Band Center Frequencies Hertz								Safe Stall Time Hot	26 s
	250	500	1000	2000	4000	8000	Hz	Safe Stall Time Cold	38 s
SPL@3	52.0	56.0	58.0	58.0	57.0	52.0	dB(A)	Frame material	cast iron
Moment of inertia	16.9 Lb-ft ²							Color, paint shade	Standard Paint - RAL7030
Ext Load Inertia Capability:	275.0 Lb ft ²							Coating (paint finish)	Standard Alkyed + Epoxy (C2)
Bearings								Ventilation Type	
Bearing DE NDE	6314 Z C3 S0			6314 Z C3 S0				Method of cooling	TEFC
Bearing_Type	Ball Bearing			Ball Bearing				Direction of rotation	Bidirectional
AFBMA:	70BC03JP30			70BC03JP30				Fan Material	Polypropylen ESD
Grease								VFD	CT: 20:1 VT: 20:1
Capacity	7.5 oz			7.5 oz				Space heaters	without
Grease Type:	Exxon Mobile EM							Brake:	without

Terminal box

Lead Wire Connection	3 LEAD - DELTA				Terminal box position	(3) F-1, Standard Floor Mount, T. Box LHS
Voltage	L1	L1	L1	Connected together	Material of terminal box	Cast Iron
----	----	----	----	----	Cable entry	3" NPT
----	T1	T2	T3	----		

Notes:

I_r/I_N = locked rotor current / current nominal
M_r/M_N = locked rotor torque / torque nominal
M_b/M_N = break down torque / nominal torque

3) Value is valid only for DOL operation with motor design IC411
2) at rated power / at full load

responsible dep. DI MC LVM	technical reference	created by DT Configurator	approved by	<i>Technical data are subject to change! There may be discrepancies between software and hardware versions</i>	
	document type datasheet	document status released	customer		
	title 1LE2321-3DB11-2AA3	document number			
© Siemens AG 2022	rev. 01	creation date 2022-04-08 22:05	language en	Page 1/1	

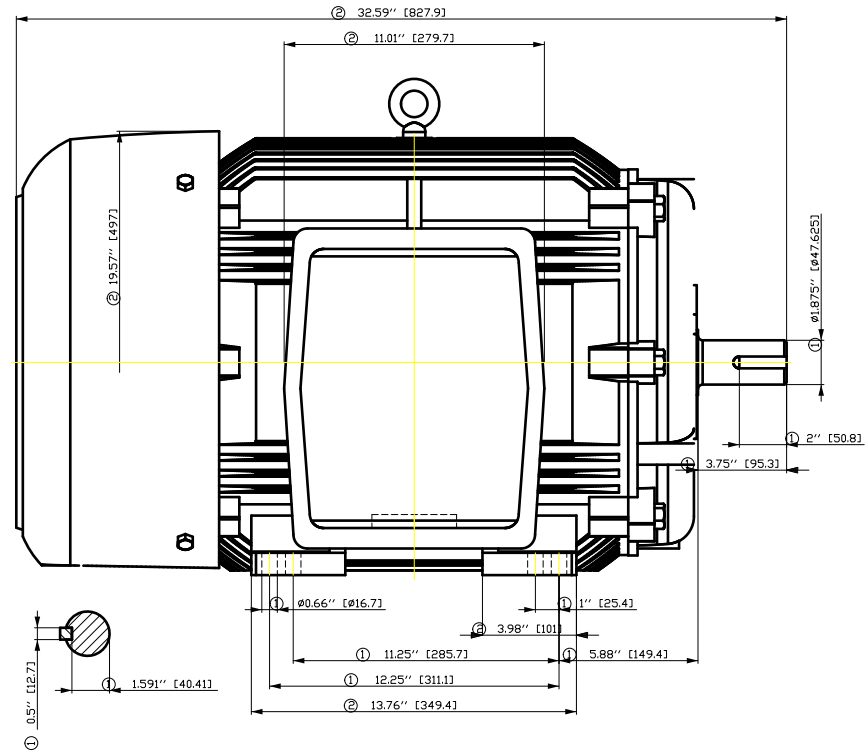
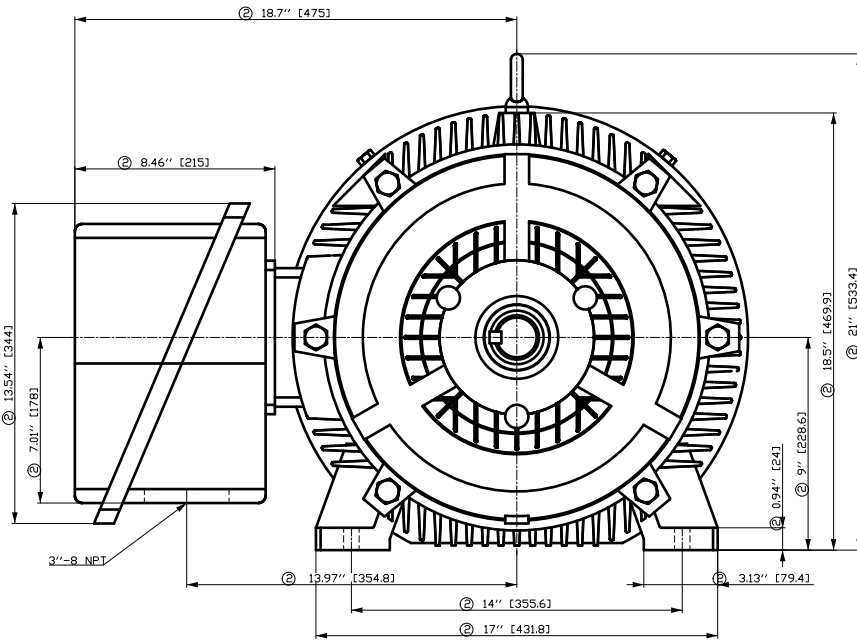

- ① Tolerances according to NEMA std.
- ② All these dimensions corresponding to assemblies and castings shall have a tolerance as per DIN standard 1686-GTB 19.
- ③ Not according to NEMA std.

刀线管
 用转为
 所全
 文
 图
 册
 积
 号
 01
 1
 2
 3
 4
 5
 6
 7
 8
 A
 B
 C
 D
 E
 F

Tolerance	Surface	Material	Weight	Scale
F50G-GFB-H0OFFE300H E	Author Creator Approval Department Change Order	ÖVS Tæ: ^æ@ } *	E	{ {
SIEMENS	Doc. State	Item No	Doc Type	
	Revision	Index	Paper Size	
	Project No	RS	1st Language	
			2nd Language	
© Siemens AG 2018	E	E	F of F	

SIEMENS INDUSTRY, INC.

HP 60 VOLTS < 600V RPM 1800 TYPE SD100
HZ 60 PHASE 3 FRAME 364TS NEMA B

TORQUE & CURRENT VS. SPEED

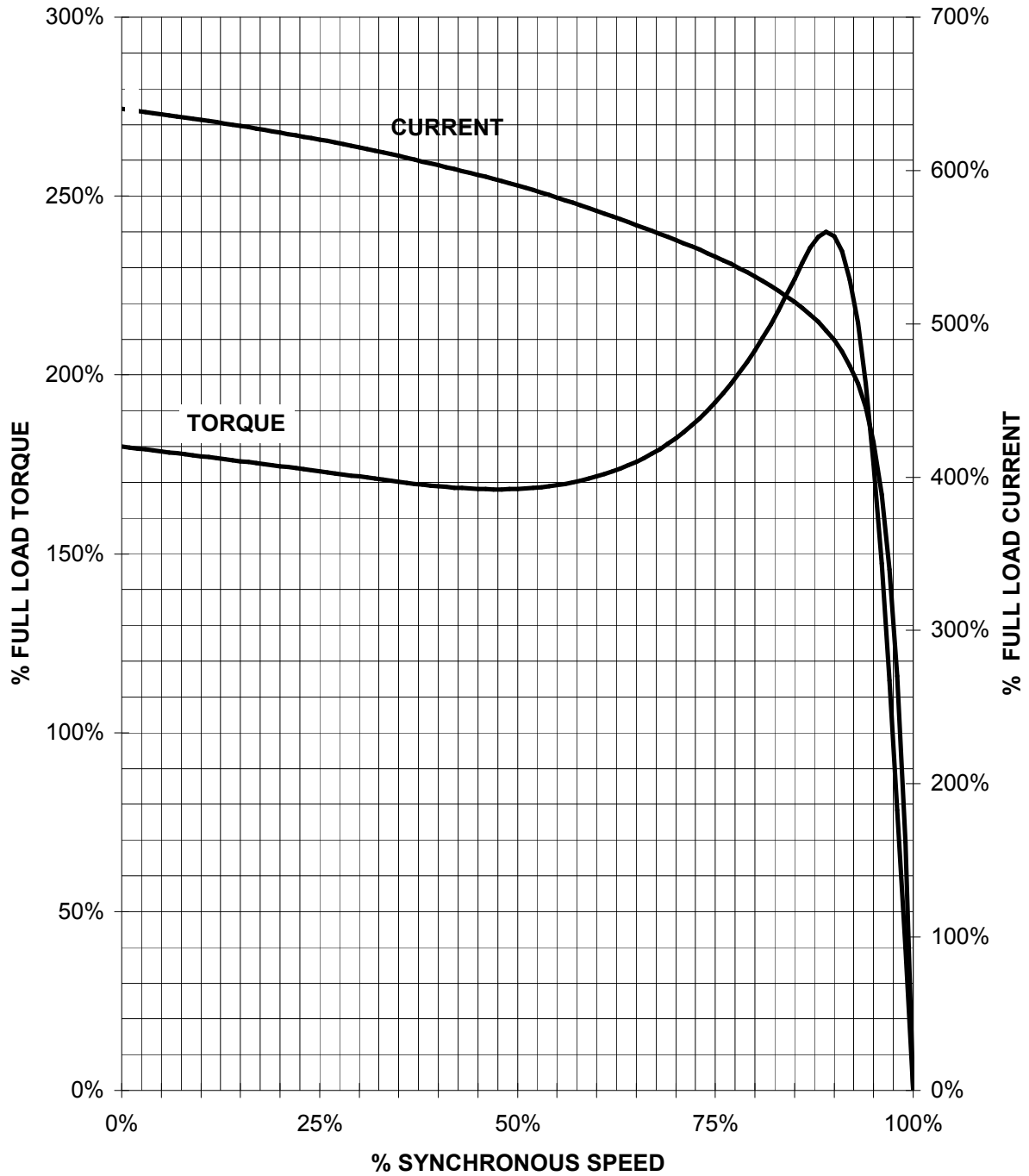

CUSTOMER: _____ ORDER#: _____

60 HP 1800 RPM 364TS FRAME 460 VOLTS 3 PHASE NEMA DESIGN B

SIEMENS INDUSTRY, INC.
PERFORMANCE CURVE
SD100

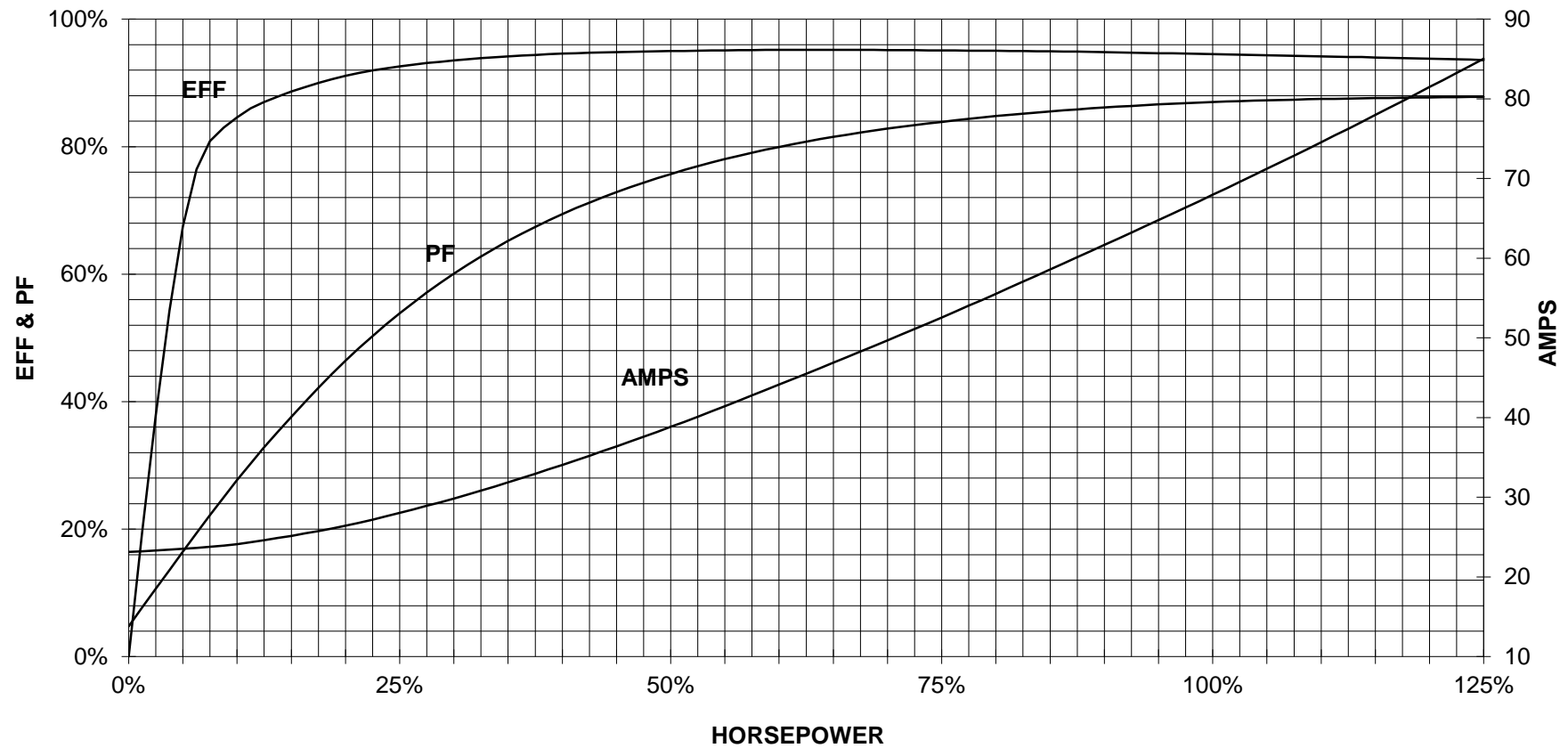

CUSTOMER: _____ ORDER #: _____

PERFORMANCE BASED ON DESIGN CALCULATIONS. SUBJECT TO CHANGE WITHOUT NOTICE.

REV. 1

Main terminal diagram



3 LEAD DELTA			
LINES			CONN.
L1	L2	L3	
T1	T2	T3	Δ

responsible dep. DI MC LVM	technical reference	created by	approved by	Project		
	document type Wiring Diagram		document status free		customer	
	title 1LE2321-3DB11-2AA3		document number			
© Siemens AG 2019			rev. 01	creation date 12/03/2019	language en	Page 1/1