

# Data sheet for three-phase Squirrel-Cage-Motors SIMOTICS

**Motor type:** SD100 IE3E **FS: 182T - 4p - 3 hp -**

Client order no.	Item-No.	Offer no.
Order no.	Consignment no.	Project
Remarks		

## Electrical data

**Class I Division 2 Gr. A, B, C or D, T3**

U [V]	$\Delta/Y$	f [Hz]	P [HP]	P [kW]	n [rpm]	I Load [Amps]					LRC	Nom. Eff Load [%]			Pwr. Factor Load [%]			Torque [lb-ft]	T <sub>A</sub> /T <sub>N</sub> LRT [%]	T <sub>k</sub> /T <sub>N</sub> BDT [%]
						4/4	3/4	1/2	0	4/4		3/4	2/4	4/4	3/4	2/4				
460	Y	60	3.00	2.00	1,800	4.00	3.30	2.70	2.10	33.0	89.5	89.4	87.8	78.5	71.7	59.5	9.0	233	356	

Frame Type: 182T	Type of constr.: ( E ) Foot mounted - C-Face	Ins. Cl.:Standard Class F Insulation	Motor Prot.:(A) Without Protection	NEMA Des.: B	S.F.: 1.15
Mtr. WT:132		Temp. Rise Cl.: B	Amb. Temp.: + 40 to -20 °C @1000 m	kVA: K	IP 55

## Mechanical data

Sound level (SPL / SWL) at 60 Hz	57.0 dB(A) / 67.0 dB(A)							Thickener	Polyurea
Octave Band Center Frequencies Hertz								Safe Stall Time Hot	17 s
	250	500	1000	2000	4000	8000	Hz	Safe Stall Time Cold	29 s
SPL@3	42.0	46.0	54.0	49.0	43.0	32.0	dB(A)	Frame material	cast iron
Moment of inertia	0.3 Lb-ft <sup>2</sup>							Color, paint shade	Standard Paint - RAL7030
Ext Load Inertia Capability:	17.0 Lb ft <sup>2</sup>							Coating (paint finish)	Standard Alkyed + Epoxy (C2)
<b>Bearings</b>								<b>Ventilation Type</b>	
Bearing DE   NDE	6206 Z C3 S0			6206 Z C3 S0				Method of cooling	TEFC
Bearing_Type	Ball Bearing			Ball Bearing				Direction of rotation	Bidirectional
AFBMA:	30BC02JP30			30BC02JP30				Fan Material	Polypropylen ESD
<b>Grease</b>								VFD	CT: 20:1 VT: 20:1
Capacity	0.2 oz			0.2 oz				Space heaters	without
Grease Type:	Exxon Mobile EM							Brake:	without

## Terminal box

Lead Wire Connection				3 LEAD - WYE	Terminal box position	(3) F-1, Standard Floor Mount, T. Box LHS
Voltage	L1	L1	L1	Connected together	Material of terminal box	Cast Iron
----	----	----	----	----	Cable entry	.75" NPT
----	T1	T2	T3	----		

### Notes:

I<sub>r</sub>/I<sub>N</sub> = locked rotor current / current nominal  
M<sub>r</sub>/M<sub>N</sub> = locked rotor torque / torque nominal  
M<sub>b</sub>/M<sub>N</sub> = break down torque / nominal torque

3) Value is valid only for DOL operation with motor design IC411  
2) at rated power / at full load

responsible dep. DI MC LVM	technical reference	created by DT Configurator	approved by	<i>Technical data are subject to change! There may be discrepancies between software and hardware versions</i>	
	document type datasheet	document status released	customer		
	title 1LE2421-1CB11-2EA3	document number			
© Siemens AG 2022	rev. 01	creation date 2022-04-08 17:32	language en	Page 1/1	

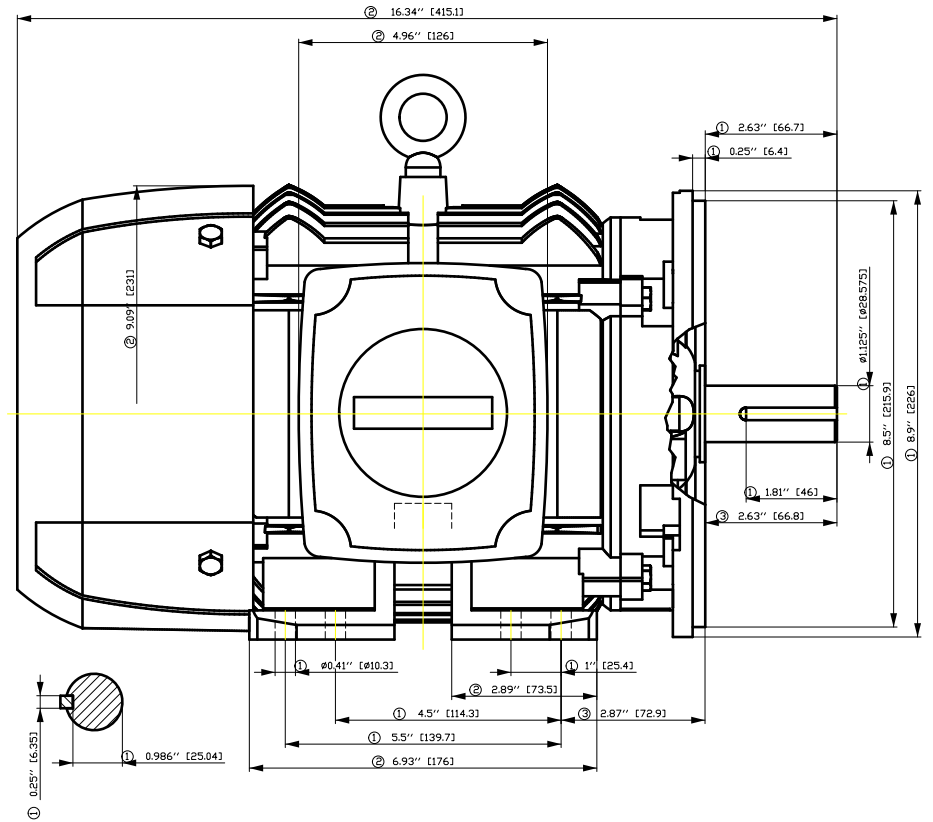
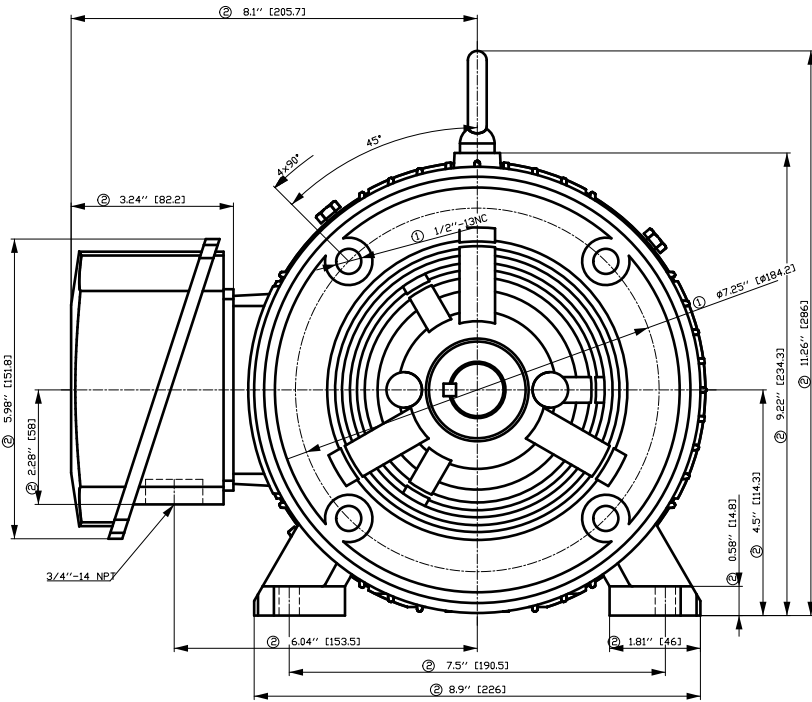

- ① Tolerances according to NEMA std.
- ② All these dimensions corresponding to assemblies and castings shall have a tolerance as per DIN standard 1686-GTB 19.
- ③ Not according to NEMA std.

Tolerance	Surface	Material	Weight	Scale
F50G GF-E00FFB00EH	Author	ÖS	E	
E	Creator			
	Approval			
	Department			
	Change Order	MFB		Doc Type
SIEMENS	Doc State	I B B G	Item No	Paper Size
	Revision	Index RS	Doc No	1st Language
				2nd Language
© Siemens AG 2018	Project No	E	Ref No	E
				Sheet F of F

# SIEMENS INDUSTRY, INC.

HP 3 VOLTS < 600V RPM 1800 TYPE SD100 IEEE841  
HZ 60 PHASE 3 FRAME 182T NEMA B

## TORQUE & CURRENT VS. SPEED

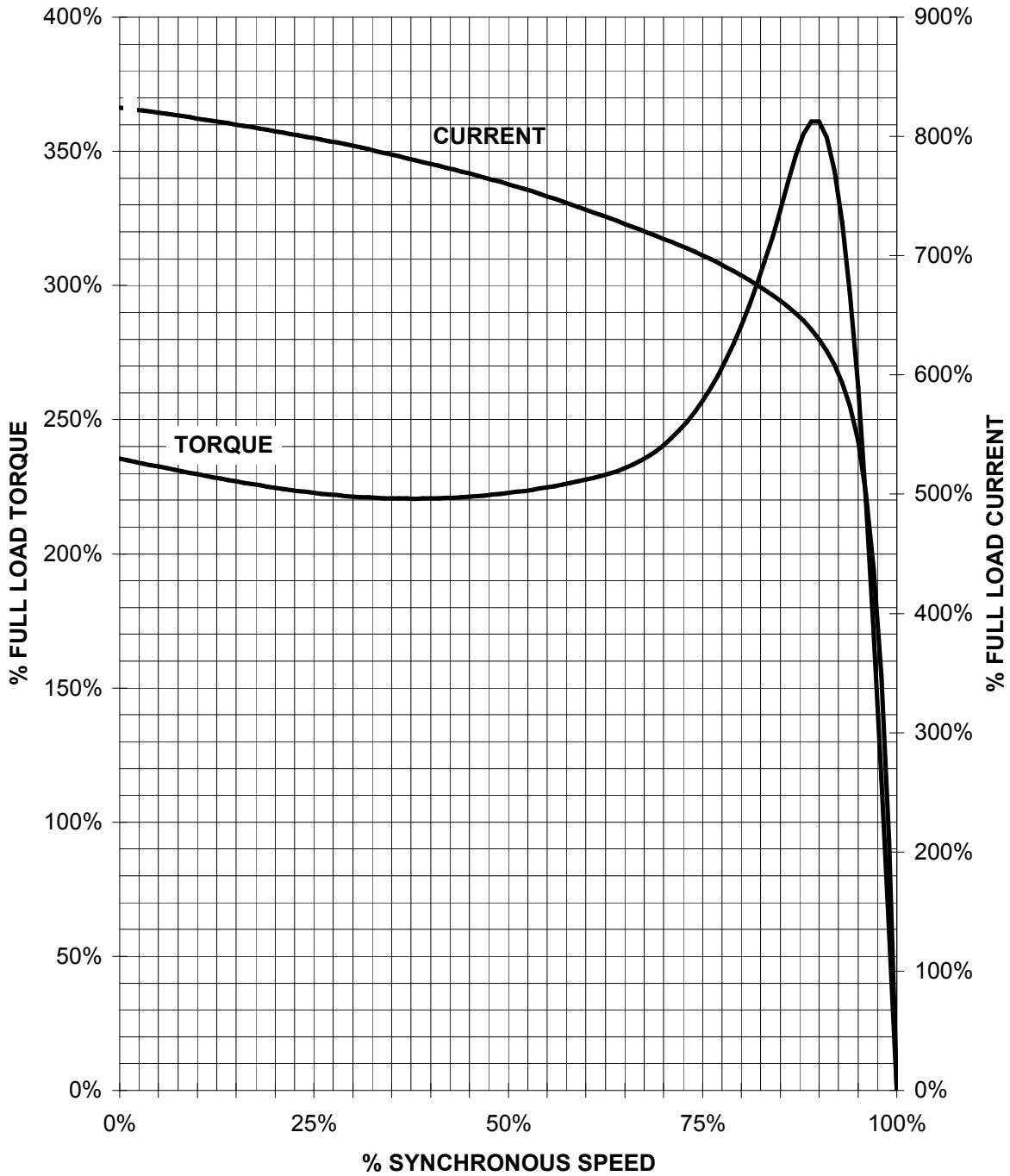

CUSTOMER: \_\_\_\_\_ ORDER#: \_\_\_\_\_

3 HP 1800 RPM 182T FRAME 460 VOLTS 3 PHASE NEMA DESIGN B

**SIEMENS INDUSTRY, INC.**  
**PERFORMANCE CURVE**  
**SD100 IEEE841**

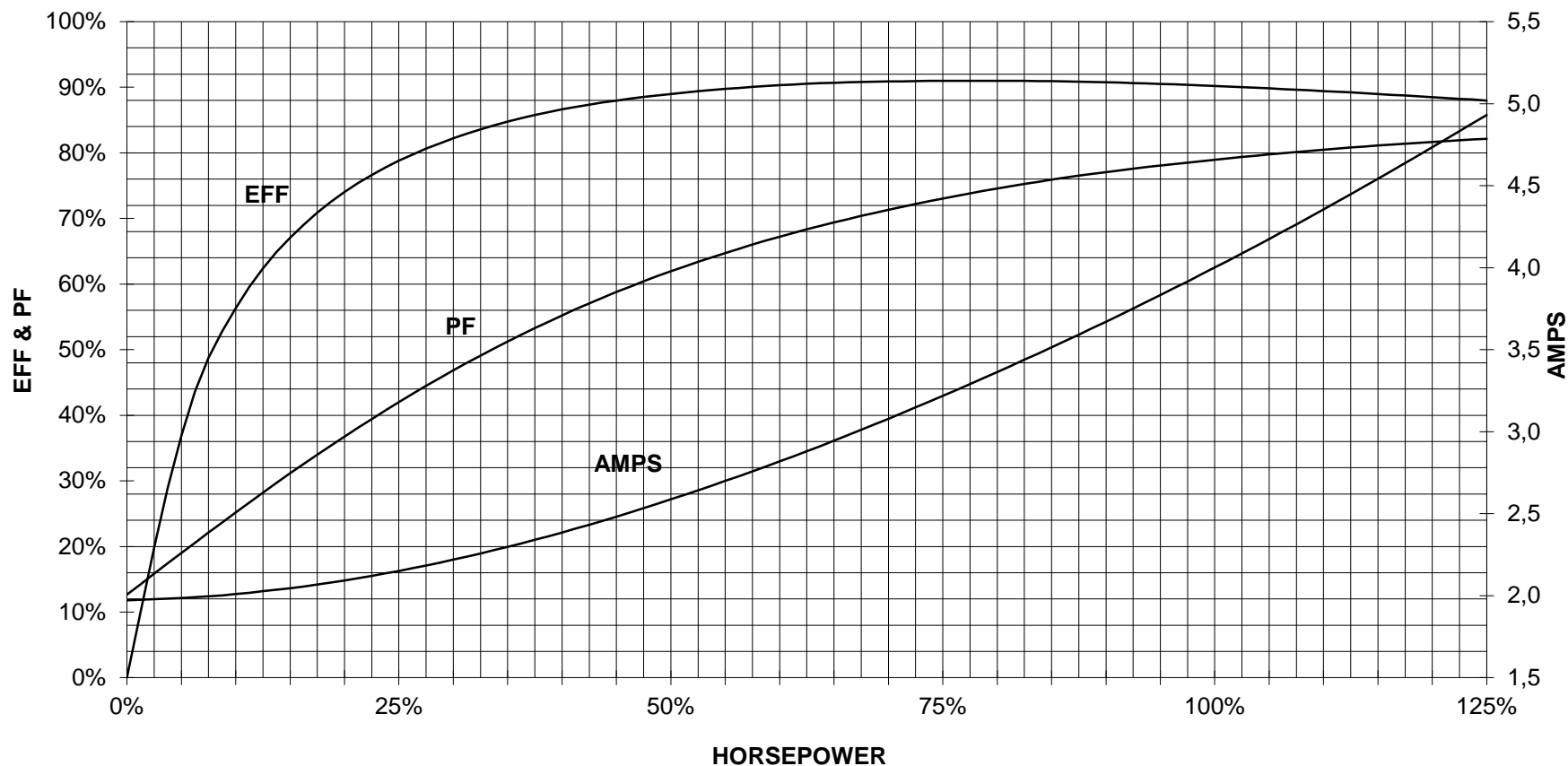

CUSTOMER \_\_\_\_\_ ORDER # \_\_\_\_\_ PO # \_\_\_\_\_

PERFORMANCE BASED ON DESIGN CALCULATIONS. SUBJECT TO CHANGE WITHOUT NOTICE.

REV. 1

Main terminal diagram



3 LEAD WYE			
LINES			CONN.
L1	L2	L3	
T1	T2	T3	

responsible dep.  
DI MC LVM

technical reference

created by

approved by

Project

**SIEMENS**

document type  
Wiring Diagram

title  
1LE2421-1CB11-2EA3

document status  
free

document number

customer