

Data sheet for three-phase Squirrel-Cage-Motors SIMOTICS

Motor type: **SD100 IEEE** FS: **254T - 2p - 15 hp -**

| | | |
|------------------|-----------------|-----------|
| Client order no. | Item-No. | Offer no. |
| Order no. | Consignment no. | Project |
| Remarks | | |

Electrical data

Class I Division 2 Gr. A, B, C or D, T3

| U [V] | Δ/Y | f [Hz] | P [HP] | P [kW] | n [rpm] | I Load [Amps] | | | | | LRC | Nom. Eff Load [%] | | | Pwr. Factor Load [%] | | | Torque [lb-ft] | T _A /T _N LRT [%] | T _k /T _N BDT [%] |
|------------------|------------|--|--------|--------|---------|---------------------------------------|-------|-------------------------------------|------|------|--------------|-------------------|------------|------|----------------------|------|------|----------------|--|--|
| | | | | | | 4/4 | 3/4 | 1/2 | 0 | 4/4 | | 3/4 | 2/4 | 4/4 | 3/4 | 2/4 | | | | |
| 575 | Y | 60 | 15.00 | 11.00 | 3,600 | 14.00 | 10.60 | 7.70 | 4.10 | 92.8 | 91.0 | 91.3 | 90.7 | 88.2 | 87.4 | 80.6 | 22.0 | 209 | 259 | |
| Frame Type: 254T | | Type of constr.: (A) Foot mounted - End shield | | | | Ins. Cl.: Standard Class F Insulation | | Motor Prot.: (A) Without Protection | | | NEMA Des.: B | | S.F.: 1.15 | | | | | | | |
| Mtr. WT: 331 | | | | | | Temp. Rise Cl.: B | | Amb. Temp.: + 40 to -20 °C @1000 m | | | kVA: G | | IP 55 | | | | | | | |

Mechanical data

| | | | | | | | | | |
|--------------------------------------|-------------------------|------|-------------------------|------------------------------|------------------|------|-------|----------------------|-----------|
| Sound level (SPL / SWL) at 60 Hz | 70.0 dB(A) / 79.0 dB(A) | | Thickener | Polyurea | | | | | |
| Octave Band Center Frequencies Hertz | | | Safe Stall Time Hot | 24 s | | | | | |
| | 250 | 500 | 1000 | 2000 | 4000 | 8000 | Hz | Safe Stall Time Cold | 48 s |
| SPL@3 | 60.0 | 73.0 | 72.0 | 75.0 | 69.0 | 56.0 | dB(A) | Frame material | cast iron |
| Moment of inertia | 1.1 Lb-ft ² | | Color, paint shade | Standard Paint - RAL7030 | | | | | |
| Ext Load Inertia Capability: | 16.0 Lb ft ² | | Coating (paint finish) | Standard Alkyed + Epoxy (C2) | | | | | |
| Bearings | | | Ventilation Type | | | | | | |
| Bearing DE NDE | 6309 Z C3 S0 | | 6309 Z C3 S0 | Method of cooling | TEFC | | | | |
| Bearing_Type | Ball Bearing | | Ball Bearing | Direction of rotation | Bidirectional | | | | |
| AFBMA: | 45BC03JP30 | | 45BC03JP30 | Fan Material | Polypropylen ESD | | | | |
| Grease | | | VFD | CT: 4:1 VT: 20:1 | | | | | |
| Capacity | 0.5 oz | | 0.5 oz | Space heaters | without | | | | |
| Grease Type: | Exxon Mobile EM | | Brake: | without | | | | | |

Terminal box

| | | | | | | |
|----------------------|------|--------------|------|--------------------|--------------------------|---|
| Lead Wire Connection | | 3 LEAD - WYE | | | Terminal box position | (3) F-1, Standard Floor Mount, T. Box LHS |
| Voltage | L1 | L1 | L1 | Connected together | Material of terminal box | Cast Iron |
| ---- | ---- | ---- | ---- | ---- | Cable entry | 1.25" NPT |
| ---- | T1 | T2 | T3 | ---- | | |

Notes:

I_L/I_N = locked rotor current / current nominal
M_L/M_N = locked rotor torque / torque nominal
M_B/M_N = break down torque / nominal torque

3) Value is valid only for DOL operation with motor design IC411
2) at rated power / at full load

| | | | | | |
|--|-----------------------------|-----------------------------------|----------------|--|--|
| responsible dep. DI MC LVM | technical reference | created by DT Configurator | approved by | <i>Technical data are subject to change! There may be discrepancies between software and hardware versions</i> | |
|  | document type datasheet | document status released | customer | | |
| | title 1LE2421-2BA11-3AA3 | document number | | | |
| © Siemens AG 2022 | rev. 01 | creation date 2022-04-08 20:01 | language en | Page 1/1 | |

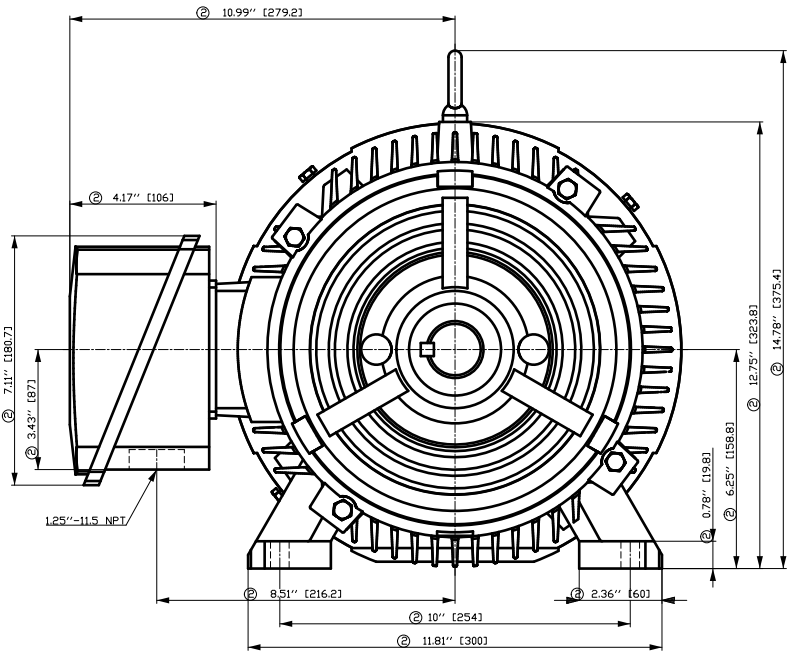

- ① Tolerances according to NEMA std.
- ② All these dimensions corresponding to assemblies and castings shall have a tolerance as per DIN standard 1686-GTB 19.
- ③ Not according to NEMA std.

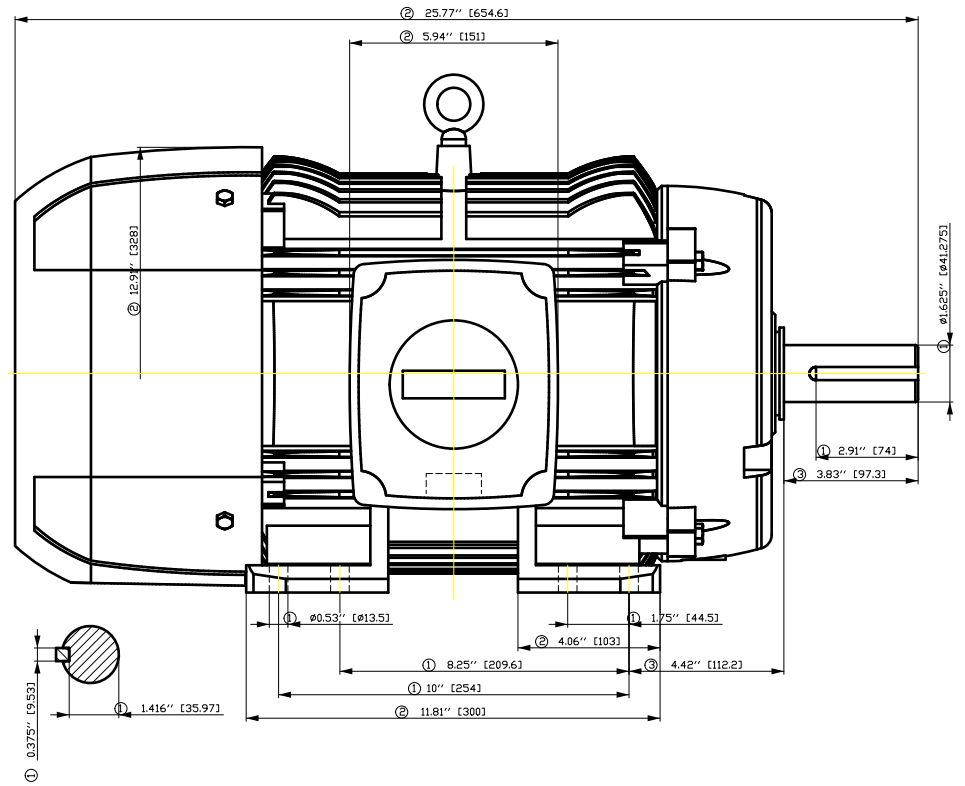

| Tolerance | Surface | Material | Weight | Scale |
|-------------------|--------------|----------|----------|--------------|
| F50G GF300FFH00H | Author | ÖS | E | 1:1 |
| E | Creator | | | |
| | Approval | | | |
| | Department | | | |
| | Change Order | MFB | Doc Type | / |
| SIEMENS | Doc. State | I 0000 | Item No. | Paper Size |
| | Revision | Index RS | Doc No. | 1st Language |
| | | | | 2nd Language |
| © Siemens AG 2018 | Project No. | E | Ref No. | E |
| | | | Sheet | F of F |

SIEMENS INDUSTRY, INC.

HP 15 VOLTS < 600V RPM 3600 TYPE SD100 IEEE841
HZ 60 PHASE 3 FRAME 254T NEMA B

TORQUE & CURRENT VS. SPEED

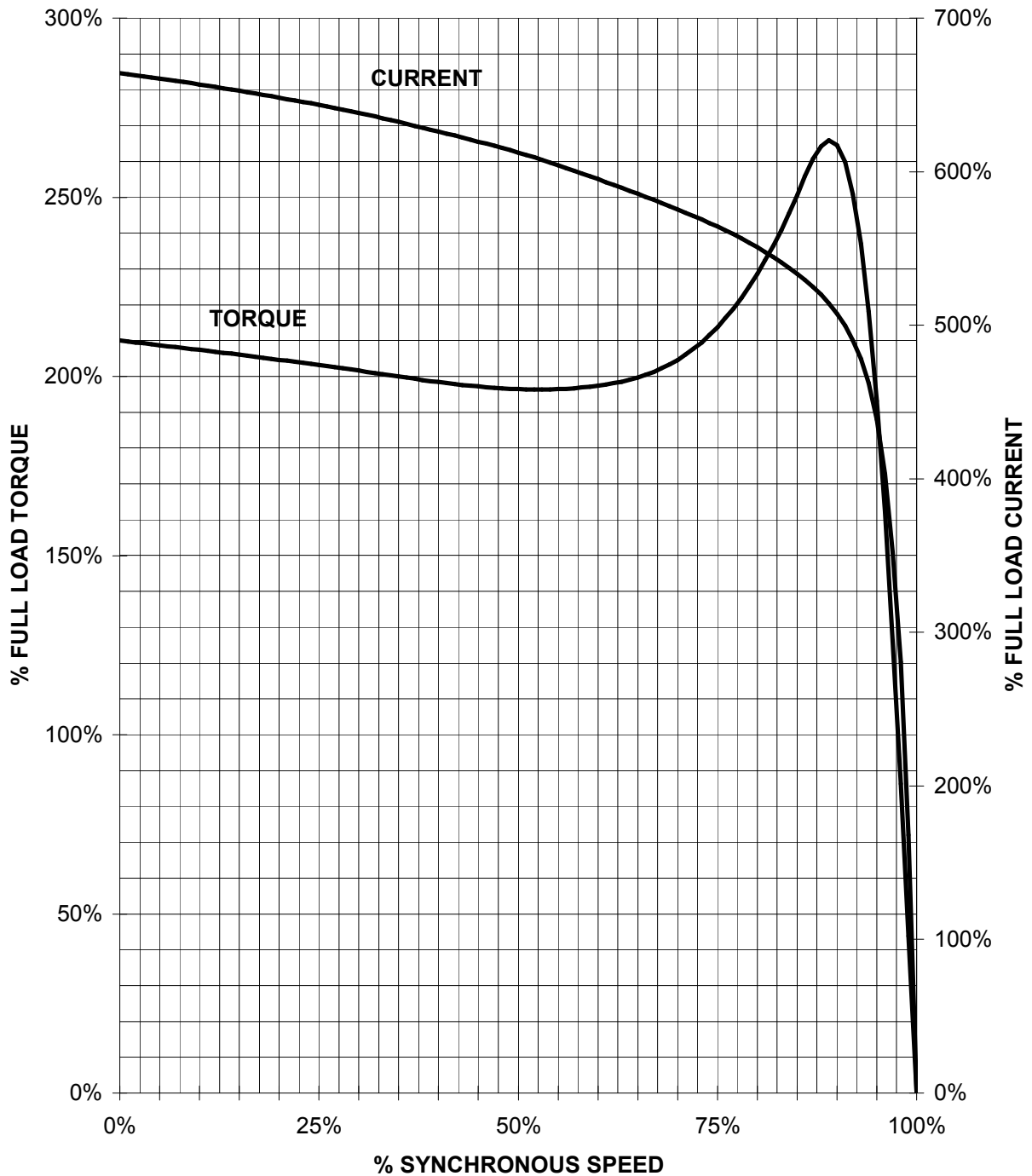

CUSTOMER: _____ ORDER#: _____

15 HP 3600 RPM 254T FRAME 575 VOLTS 3 PHASE NEMA DESIGN B

SIEMENS INDUSTRY, INC.
PERFORMANCE CURVE
SD100 IEEE841

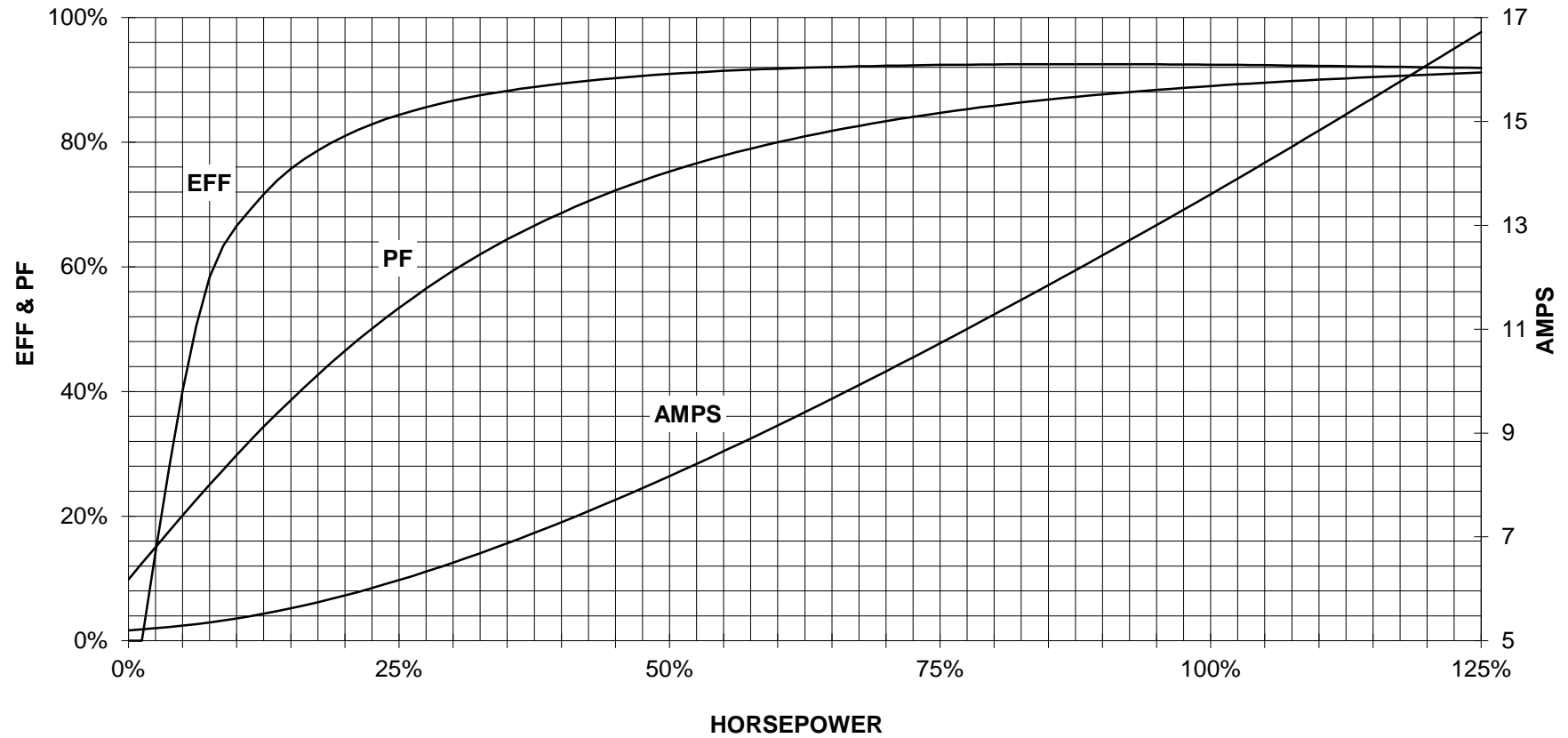

CUSTOMER _____ ORDER # _____ PO # _____

PERFORMANCE BASED ON DESIGN CALCULATIONS. SUBJECT TO CHANGE WITHOUT NOTICE.

REV. 1

Main terminal diagram



| 3 LEAD WYE | | | |
|------------|----|----|-------|
| LINES | | | CONN. |
| L1 | L2 | L3 | |
| T1 | T2 | T3 | Y |

| | | | | | | |
|--|---------------------------------|------------|-------------------------|-----------------------------|----------------|-------------|
| responsible dep. DI MC LVM | technical reference | created by | approved by | Project | | |
|  | document type Wiring Diagram | | document status free | | customer | |
| | title 1LE2421-2BA11-3AA3 | | document number | | | |
| © Siemens AG 2019 | | | rev. 01 | creation date 12/03/2019 | language en | Page 1/1 |