

Data sheet for three-phase Squirrel-Cage-Motors SIMOTICS

Motor type: SD100 IEEE **FS: 256T - 4p - 20 hp -**

Client order no.	Item-No.	Offer no.
Order no.	Consignment no.	Project
Remarks		

Electrical data

Class I Division 2 Gr. A, B, C or D, T3

U [V]	Δ/Y	f [Hz]	P [HP]	P [kW]	n [rpm]	I Load [Amps]					LRC	Nom. Eff Load [%]			Pwr. Factor Load [%]			Torque [lb-ft]	T _A /T _N LRT [%]	T _k /T _N BDT [%]
						4/4	3/4	1/2	0	4/4		3/4	2/4	4/4	3/4	2/4				
460	Y	60	20.00	15.00	1,800	25.00	19.80	15.40	10.50	145.0	93.0	93.4	93.1	80.5	75.9	65.3	60.0	183	240	
Frame Type: 256T		Type of constr.: (A) Foot mounted - End shield				Ins. Cl.: Standard Class F Insulation		Motor Prot.: (A) Without Protection			NEMA Des.: B		S.F.: 1.15							
Mtr. WT: 319						Temp. Rise Cl.: B		Amb. Temp.: + 40 to -20 °C @1000 m			kVA: G		IP 55							

Mechanical data

Sound level (SPL / SWL) at 60 Hz	61.0 dB(A) / 73.0 dB(A)		Thickener	Polyurea					
Octave Band Center Frequencies Hertz			Safe Stall Time Hot	15 s					
	250	500	1000	2000	4000	8000	Hz	Safe Stall Time Cold	33 s
SPL@3	47.0	53.0	59.0	56.0	47.0	38.0	dB(A)	Frame material	cast iron
Moment of inertia	2.1 Lb-ft ²		Color, paint shade	Standard Paint - RAL7030					
Ext Load Inertia Capability:	99.0 Lb ft ²		Coating (paint finish)	Standard Alkyed + Epoxy (C2)					
Bearings			Ventilation Type						
Bearing DE NDE	6309 Z C3 S0		6309 Z C3 S0	Method of cooling	TEFC				
Bearing_Type	Ball Bearing		Ball Bearing	Direction of rotation	Bidirectional				
AFBMA:	45BC03JP30		45BC03JP30	Fan Material	Polypropylen ESD				
Grease			VFD	CT: 20:1	VT: 20:1				
Capacity	0.5 oz		0.5 oz	Space heaters	without				
Grease Type:	Exxon Mobile EM		Brake:	without					

Terminal box

Lead Wire Connection	3 LEAD - WYE				Terminal box position	(3) F-1, Standard Floor Mount, T. Box LHS
Voltage	L1	L1	L1	Connected together	Material of terminal box	Cast Iron
----	----	----	----	----	Cable entry	1.25" NPT
----	T1	T2	T3	----		

Notes:

I_L/I_N = locked rotor current / current nominal
M_L/M_N = locked rotor torque / torque nominal
M_B/M_N = break down torque / nominal torque

3) Value is valid only for DOL operation with motor design IC411
2) at rated power / at full load

responsible dep. DI MC LVM	technical reference	created by DT Configurator	approved by	<i>Technical data are subject to change! There may be discrepancies between software and hardware versions</i>	
	document type datasheet	document status released	customer		
	title 1LE2421-2BB21-2AA3	document number			
© Siemens AG 2022	rev. 01	creation date 2022-04-08 20:05	language en	Page 1/1	

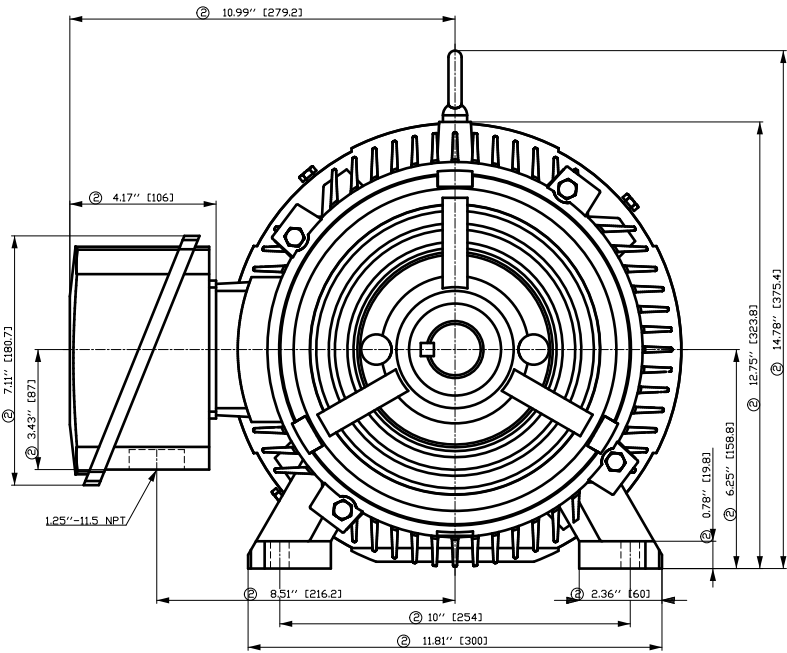

- ① Tolerances according to NEMA std.
- ② All these dimensions corresponding to assemblies and castings shall have a tolerance as per DIN standard 1686-GTB 19.
- ③ Not according to NEMA std.

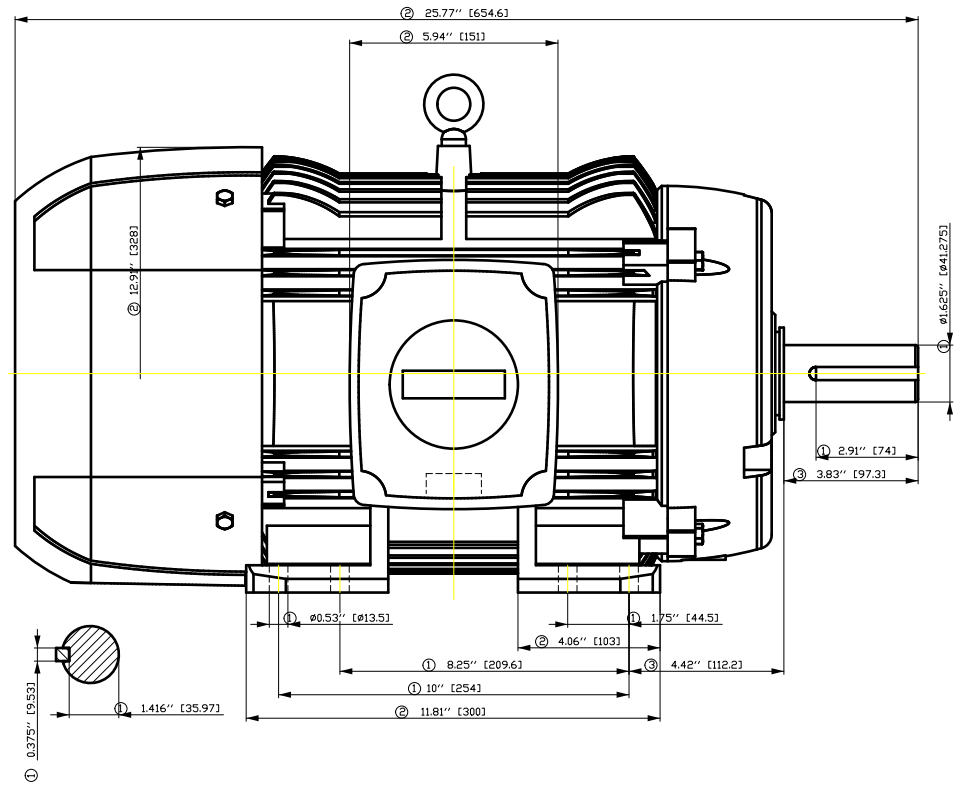

Tolerance	Surface	Material	Weight	Scale
F50G GF E300H	Author	ÖS	E	
E	Creator			
	Approval			
	Department			
	Change Order	MFB	Doc Type	
	Doc. State	I 0000	Item No	Paper Size
	Revision	Index RS	Doc No	1st Language
				2nd Language
© Siemens AG 2018	Project No	E	Ref No	E
				Sheet F of F

SIEMENS INDUSTRY, INC.

HP 20 VOLTS < 600V RPM 1800 TYPE SD100 IEEE841
HZ 60 PHASE 3 FRAME 256T NEMA B

TORQUE & CURRENT VS. SPEED

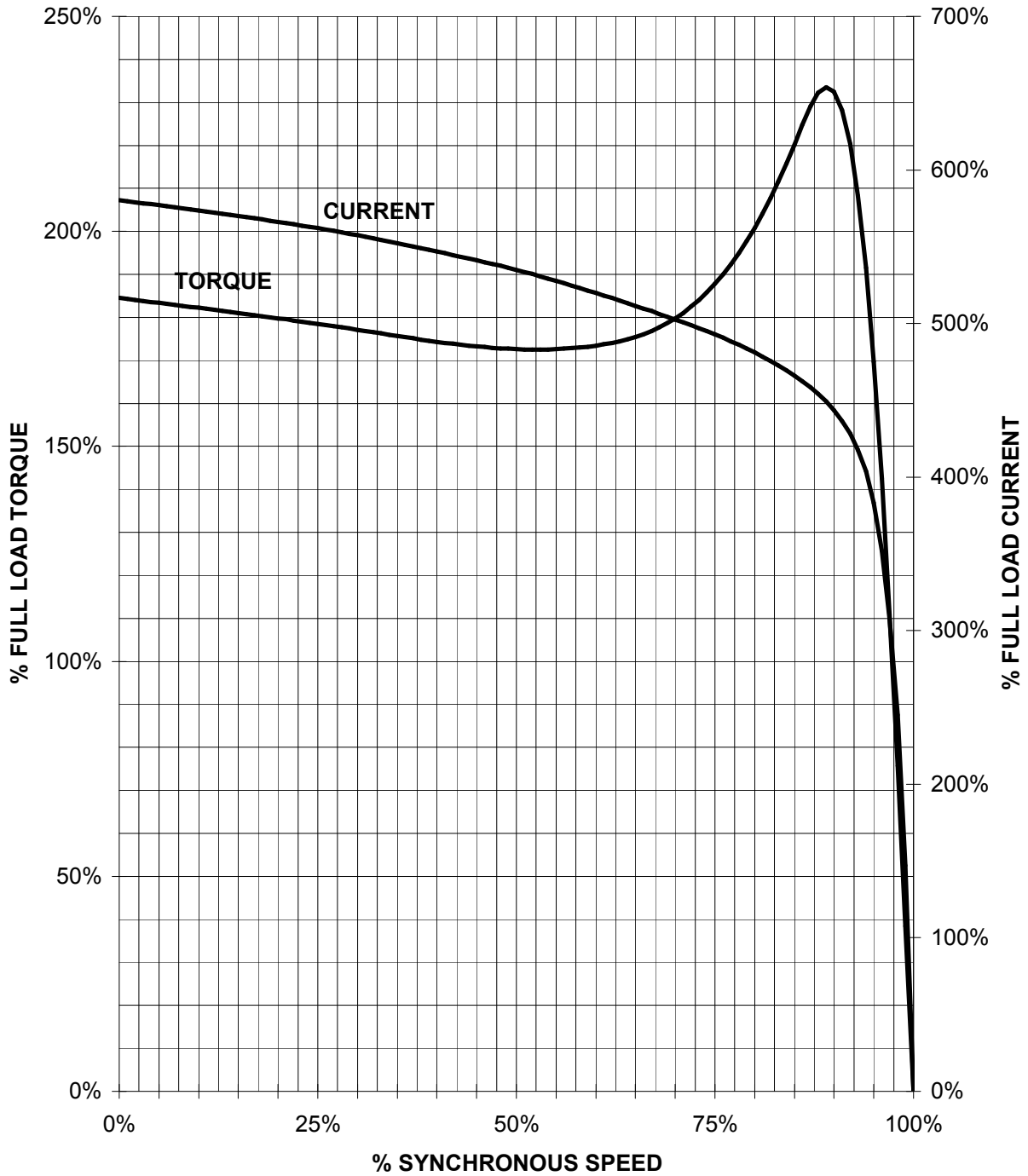

CUSTOMER: _____ ORDER#: _____

20 HP 1800 RPM 256T FRAME 460 VOLTS 3 PHASE NEMA DESIGN B

SIEMENS INDUSTRY, INC.
PERFORMANCE CURVE
SD100 IEEE841

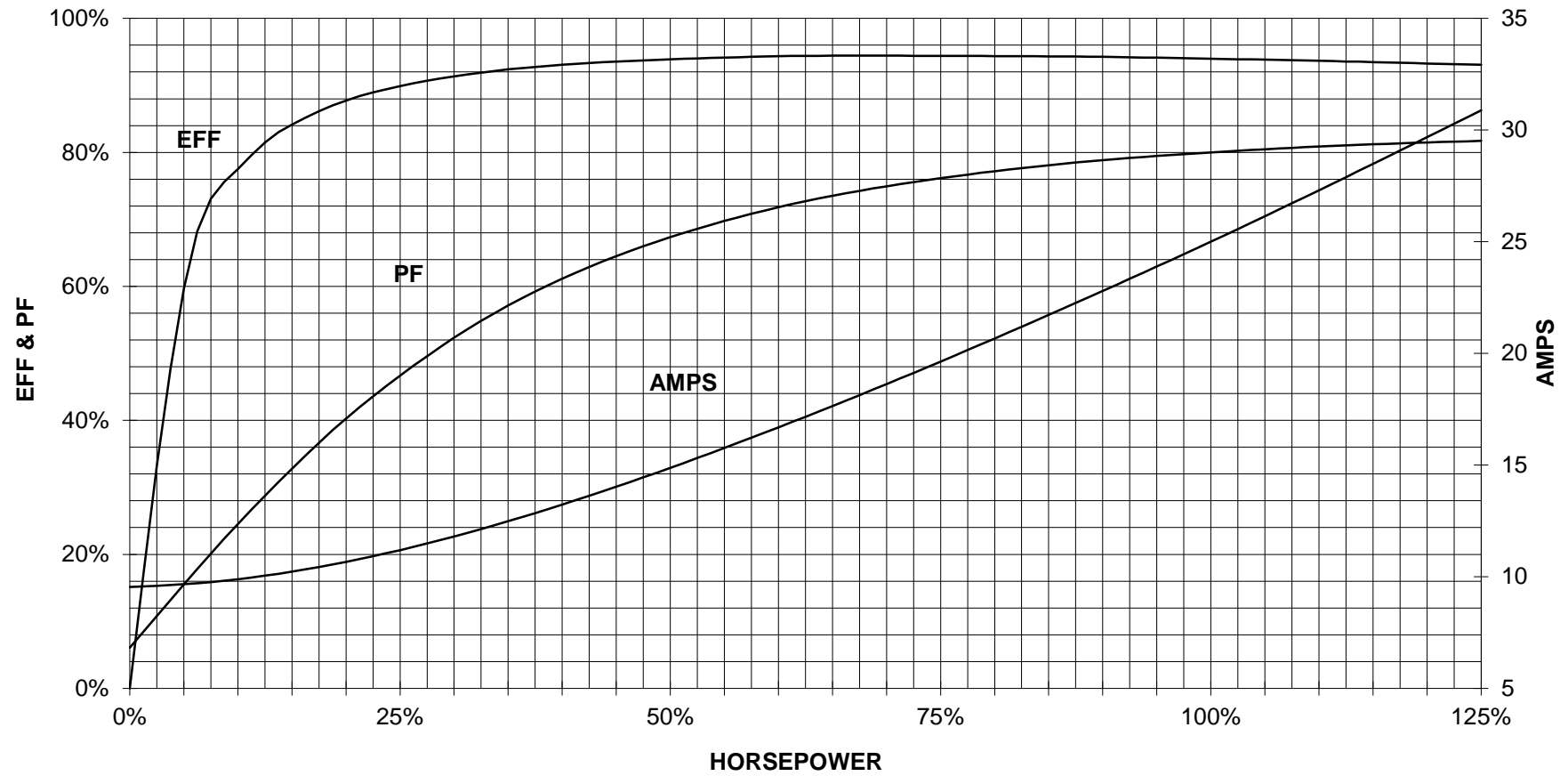

CUSTOMER _____ ORDER # _____ PO # _____

PERFORMANCE BASED ON DESIGN CALCULATIONS. SUBJECT TO CHANGE WITHOUT NOTICE.

REV. 1

Main terminal diagram



3 LEAD WYE			
LINES			CONN.
L1	L2	L3	
T1	T2	T3	Y

responsible dep. DI MC LVM	technical reference	created by	approved by	Project
SIEMENS	document type Wiring Diagram	document status free		customer
	title 1LE2421-2BB21-2AA3	document number		
© Siemens AG 2019	rev. 01	creation date 12/03/2019	language en	Page 1/1