

Data sheet for three-phase Squirrel-Cage-Motors SIMOTICS

Motor type: **SD100 IEEE** FS: **284TS - 2p - 25 hp -**

Client order no.	Item-No.	Offer no.
Order no.	Consignment no.	Project

Remarks

Electrical data

Class I Division 2 Gr. A, B, C or D, T3

U [V]	Δ / Y	f [Hz]	P [HP]	P [kW]	n [rpm]	I Load [Amps]					LRC	Nom. Eff Load [%]			Pwr. Factor Load [%]			Torque [lb-ft]	T _A /T _N LRT [%]	T _k /T _N BDT [%]
						4/4	3/4	1/2	0	4/4		3/4	2/4	4/4	3/4	2/4				
575	Δ	60	25.00	18.50	3,600	23.20	17.90	12.70	6.40	146.4	91.7	92.2	92.0	88.0	85.0	80.0	37.0	159	251	

Frame Type: 284TS	Type of constr.: (A) Foot mounted - End shield	Ins. Cl.: Standard Class F Insulation	Motor Prot.: (A) Without Protection	NEMA Des.: B	S.F.: 1.15
Mtr. WT: 396		Temp. Rise Cl.: B	Amb. Temp.: + 40 to -20 °C @1000 m	kVA: G	IP 55

Mechanical data

Sound level (SPL / SWL) at 60 Hz	72.0 dB(A) / 83.0 dB(A)							Thickener	Polyurea
Octave Band Center Frequencies Hertz								Safe Stall Time Hot	16 s
	250	500	1000	2000	4000	8000	Hz	Safe Stall Time Cold	30 s
SPL@3	57.0	65.0	64.0	69.0	65.0	54.0	dB(A)	Frame material	cast iron
Moment of inertia	1.4 Lb-ft ²							Color, paint shade	Standard Paint - RAL7030
Ext Load Inertia Capability:	26.0 Lb ft ²							Coating (paint finish)	Standard Alkyed + Epoxy (C2)
Bearings								Ventilation Type	
Bearing DE NDE	6310 Z C3 S0			6310 Z C3 S0				Method of cooling	TEFC
Bearing_Type	Ball Bearing			Ball Bearing				Direction of rotation	Bidirectional
AFBMA:	50BC03JP30			50BC03JP30				Fan Material	Polypropylen ESD
Grease								VFD	CT: 4:1 VT: 20:1
Capacity	2.6 oz			2.6 oz				Space heaters	without
Grease Type:	Exxon Mobile EM							Brake:	without

Terminal box

Lead Wire Connection	3 LEAD - DELTA				Terminal box position	(3) F-1, Standard Floor Mount, T. Box LHS
Voltage	L1	L1	L1	Connected together	Material of terminal box	Cast Iron
----	----	----	----	----	Cable entry	1.5" NPT
----	T1	T2	T3	----		

Notes:

I_L/I_N = locked rotor current / current nominal
M_L/M_N = locked rotor torque / torque nominal
M_B/M_N = break down torque / nominal torque

3) Value is valid only for DOL operation with motor design IC411
2) at rated power / at full load

responsible dep. DI MC LVM	technical reference	created by DT Configurator	approved by	<i>Technical data are subject to change! There may be discrepancies between software and hardware versions</i>			
	document type datasheet	document status released		customer			
	title 1LE2421-2DA11-3AA3	document number					
© Siemens AG 2022	rev. 01	creation date 2022-04-08 20:51	language en	Page 1/1			

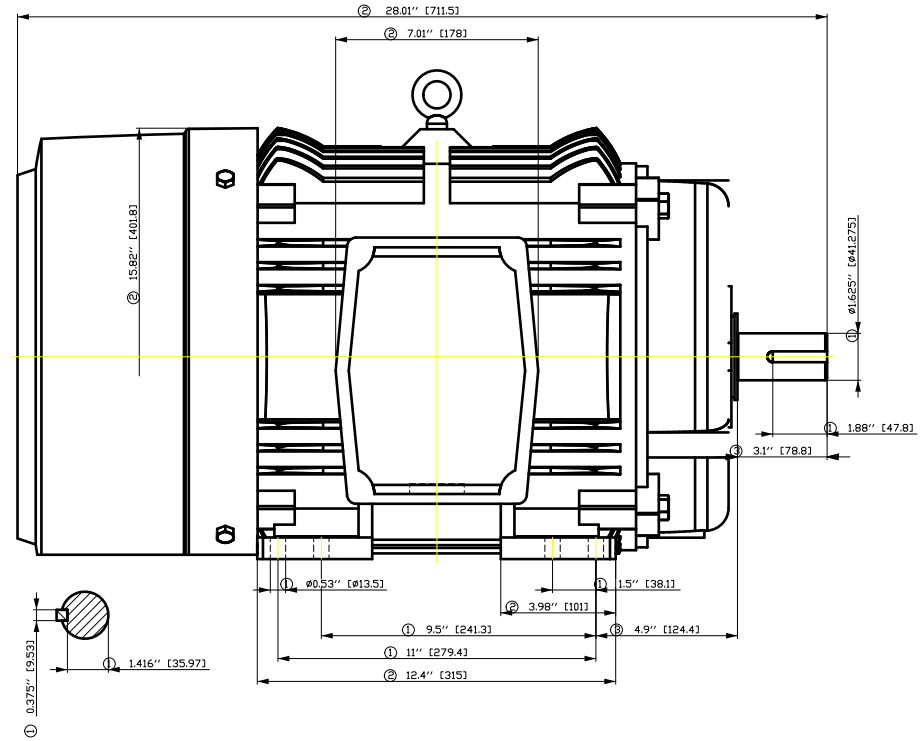
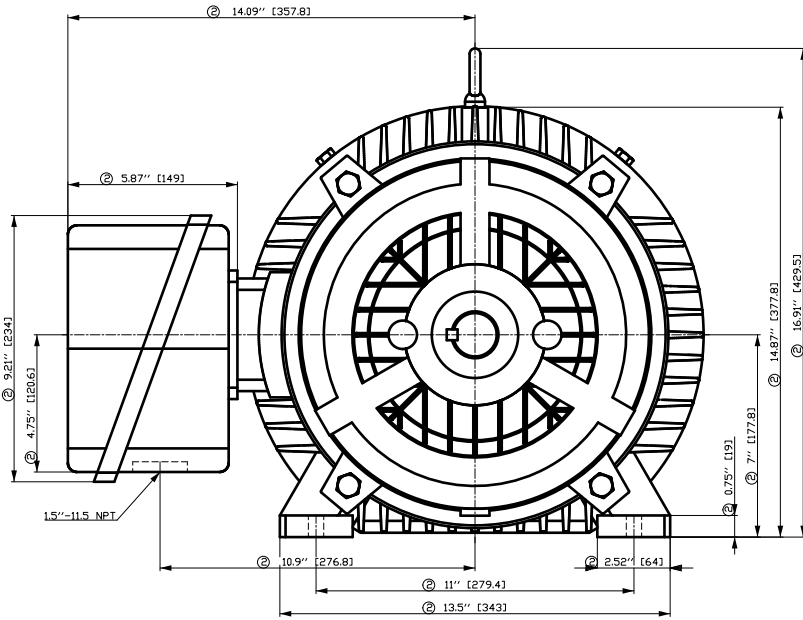

- ① Tolerances according to NEMA std.
- ② All these dimensions corresponding to assemblies and castings shall have a tolerance as per DIN standard 1686-GTB 19.
- ③ Not according to NEMA std.

Tolerance	Surface	Material	Weight	Scale
F50G GF300FFH00H E	Author Creator Approval Department Change Order	ÖVS T a : ^ & @ } *	E	{ {
SIEMENS	Doc. State	Item No	Doc Type	
	Revision	Index	Doc No	Paper Size
© Siemens AG 2018	Project No	Ref No	1st Language	2nd Language
	E	E	^	â
			Sheet	F of F

SIEMENS INDUSTRY, INC.

HP 25 VOLTS < 600V RPM 3600 TYPE SD100 IEEE841
HZ 60 PHASE 3 FRAME 284TS NEMA B

TORQUE & CURRENT VS. SPEED

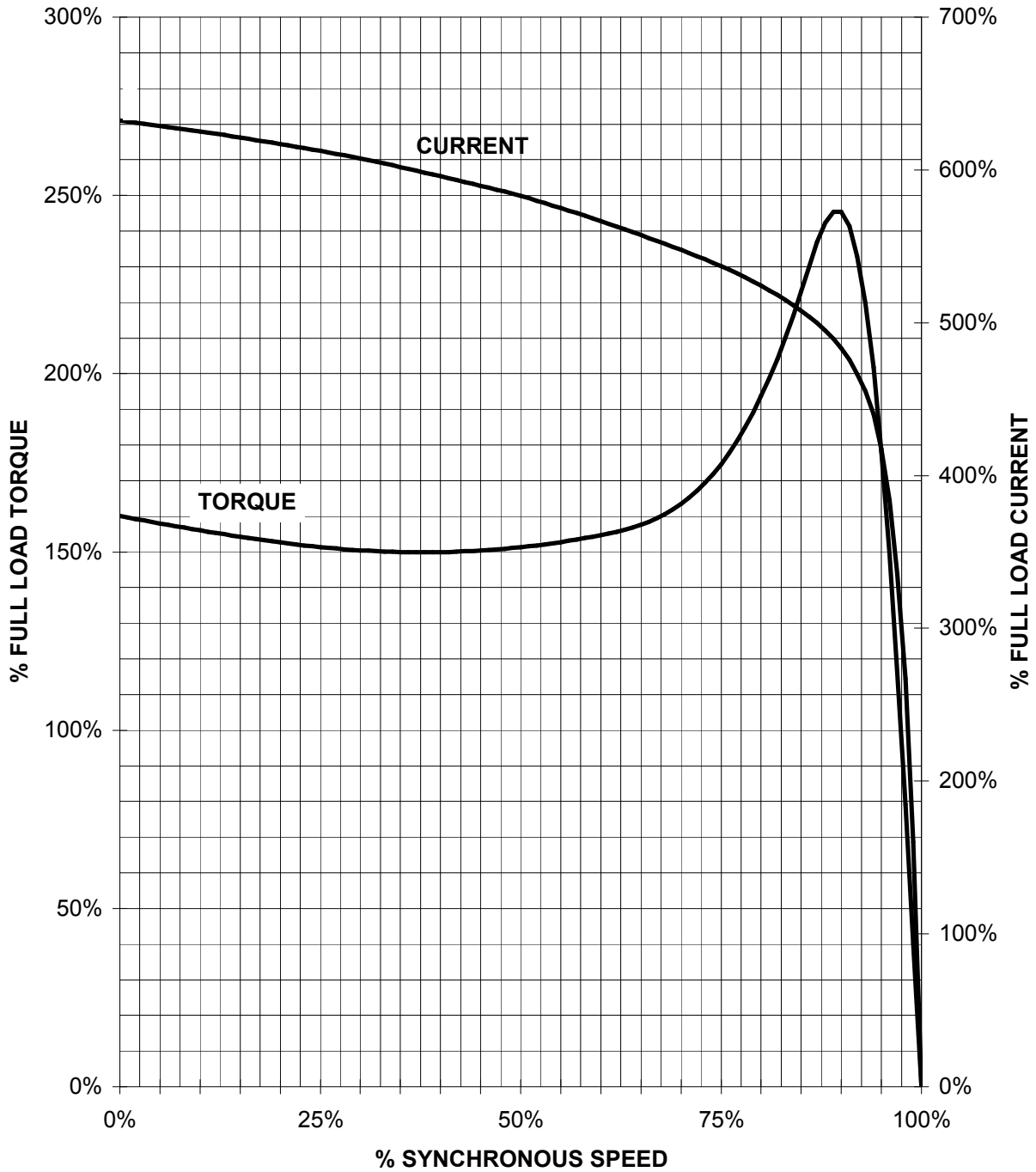

CUSTOMER: _____ ORDER#: _____

25 HP 3600 RPM 284TS FRAME 575 VOLTS 3 PHASE NEMA DESIGN B

SIEMENS INDUSTRY, INC.
PERFORMANCE CURVE
SD100 IEEE841

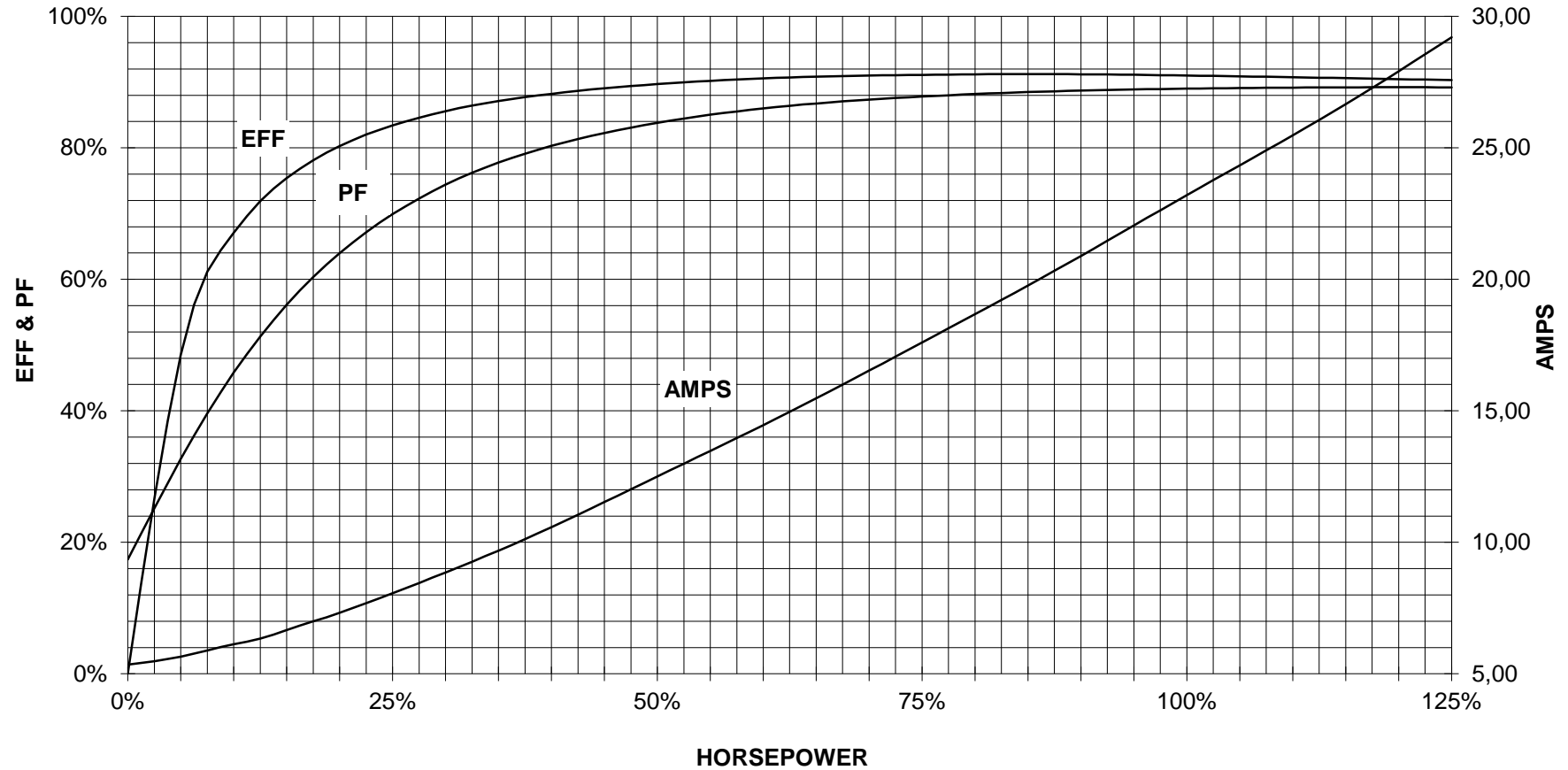

CUSTOMER _____ ORDER # _____ PO # _____

PERFORMANCE BASED ON DESIGN CALCULATIONS. SUBJECT TO CHANGE WITHOUT NOTICE.

REV. 1

Main terminal diagram

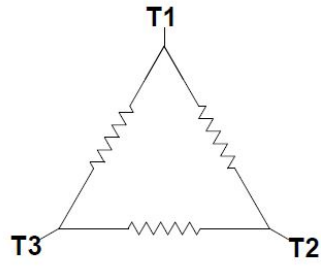

3 LEAD DELTA			
LINES			CONN.
L1	L2	L3	
T1	T2	T3	Δ

responsible dep. DI MC LVM	technical reference	created by	approved by	Project
SIEMENS	document type Wiring Diagram	document status free		customer
	title 1LE2421-2DA11-3AA3	document number		
© Siemens AG 2019		rev. 01	creation date 12/03/2019	language en Page 1/1