

Data sheet for three-phase Squirrel-Cage-Motors SIMOTICS

Motor type: **SD100 IEEE** FS: **324T - 8p - 20 hp -**

| | | |
|------------------|-----------------|-----------|
| Client order no. | Item-No. | Offer no. |
| Order no. | Consignment no. | Project |

Remarks

Electrical data

Class I Division 2 Gr. A, B, C or D, T3

| U [V] | Δ / Y | f [Hz] | P [HP] | P [kW] | n [rpm] | I Load [Amps] | | | | | LRC | Nom. Eff Load [%] | | | Pwr. Factor Load [%] | | | Torque [lb-ft] | T _A /T _N LRT [%] | T _k /T _N BDT [%] |
|-------|--------------|--------|--------|--------|---------|---------------|-------|-------|-------|-------|------|-------------------|------|------|----------------------|------|-------|----------------|--|--|
| | | | | | | 4/4 | 3/4 | 1/2 | 0 | 4/4 | | 3/4 | 2/4 | 4/4 | 3/4 | 2/4 | | | | |
| 460 | Δ | 60 | 20.00 | 15.00 | 900 | 31.00 | 25.30 | 20.90 | 18.00 | 145.0 | 91.0 | 91.1 | 89.8 | 67.0 | 61.0 | 50.0 | 119.0 | 140 | 200 | |

| | | | | | |
|------------------|--|---------------------------------------|-------------------------------------|--------------|------------|
| Frame Type: 324T | Type of constr.: (A) Foot mounted - End shield | Ins. Cl.: Standard Class F Insulation | Motor Prot.: (A) Without Protection | NEMA Des.: B | S.F.: 1.15 |
| Mtr. WT: 570 | | Temp. Rise Cl.: B | Amb. Temp.: + 40 to -20 °C @1000 m | kVA: G | IP 55 |

Mechanical data

| | | | | | | | | | |
|--------------------------------------|--------------------------|------|------|--------------|------|------|-------|-------------------------|------------------------------|
| Sound level (SPL / SWL) at 60 Hz | 63.0 dB(A) / 73.0 dB(A) | | | | | | | Thickener | Polyurea |
| Octave Band Center Frequencies Hertz | | | | | | | | Safe Stall Time Hot | 15 s |
| | 250 | 500 | 1000 | 2000 | 4000 | 8000 | Hz | Safe Stall Time Cold | 35 s |
| SPL@3 | 51.0 | 57.0 | 58.0 | 56.0 | 51.0 | 50.0 | dB(A) | Frame material | cast iron |
| Moment of inertia | 0.0 Lb-ft ² | | | | | | | Color, paint shade | Standard Paint - RAL7030 |
| Ext Load Inertia Capability: | 525.0 Lb ft ² | | | | | | | Coating (paint finish) | Standard Alkyed + Epoxy (C2) |
| Bearings | | | | | | | | Ventilation Type | |
| Bearing DE NDE | 6312 Z C3 S0 | | | 6312 Z C3 S0 | | | | Method of cooling | TEFC |
| Bearing_Type | Ball Bearing | | | Ball Bearing | | | | Direction of rotation | Bidirectional |
| AFBMA: | 60BC03JP30 | | | 60BC03JP30 | | | | Fan Material | Polypropylen ESD |
| Grease | | | | | | | | VFD | CT: 4:1 VT: 20:1 |
| Capacity | 5.5 oz | | | 5.5 oz | | | | Space heaters | without |
| Grease Type: | Exxon Mobile EM | | | | | | | Brake: | without |

Terminal box

| | | | | | | |
|----------------------|----------------|------|------|--------------------|--------------------------|---|
| Lead Wire Connection | 3 LEAD - DELTA | | | | Terminal box position | (3) F-1, Standard Floor Mount, T. Box LHS |
| Voltage | L1 | L1 | L1 | Connected together | Material of terminal box | Cast Iron |
| ---- | ---- | ---- | ---- | ---- | Cable entry | 2" NPT |
| ---- | T1 | T2 | T3 | ---- | | |

Notes:

I_L/I_N = locked rotor current / current nominal
M_L/M_N = locked rotor torque / torque nominal
M_B/M_N = break down torque / nominal torque

3) Value is valid only for DOL operation with motor design IC411
2) at rated power / at full load

| | | | | |
|-------------------------------|---------------------|-------------------------------|-------------|--|
| responsible dep. DI MC LVM | technical reference | created by DT Configurator | approved by | <i>Technical data are subject to change! There may be discrepancies between software and hardware versions</i> |
|-------------------------------|---------------------|-------------------------------|-------------|--|

| | | | | |
|--|-----------------------------|-----------------------------------|----------------|-------------|
|  | document type datasheet | document status released | customer | |
| | title 1LE2421-3AD11-2AA3 | document number | | |
| © Siemens AG 2022 | rev. 01 | creation date 2022-04-08 21:30 | language en | Page 1/1 |

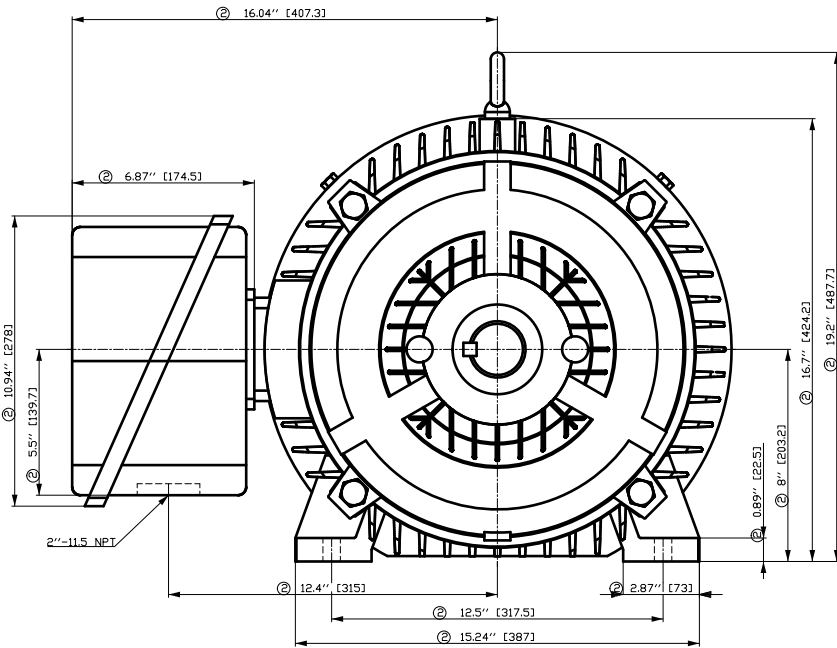

- ① Tolerances according to NEMA std.
- ② All these dimensions corresponding to assemblies and castings shall have a tolerance as per DIN standard 1686-GTB 19.
- ③ Not according to NEMA std.

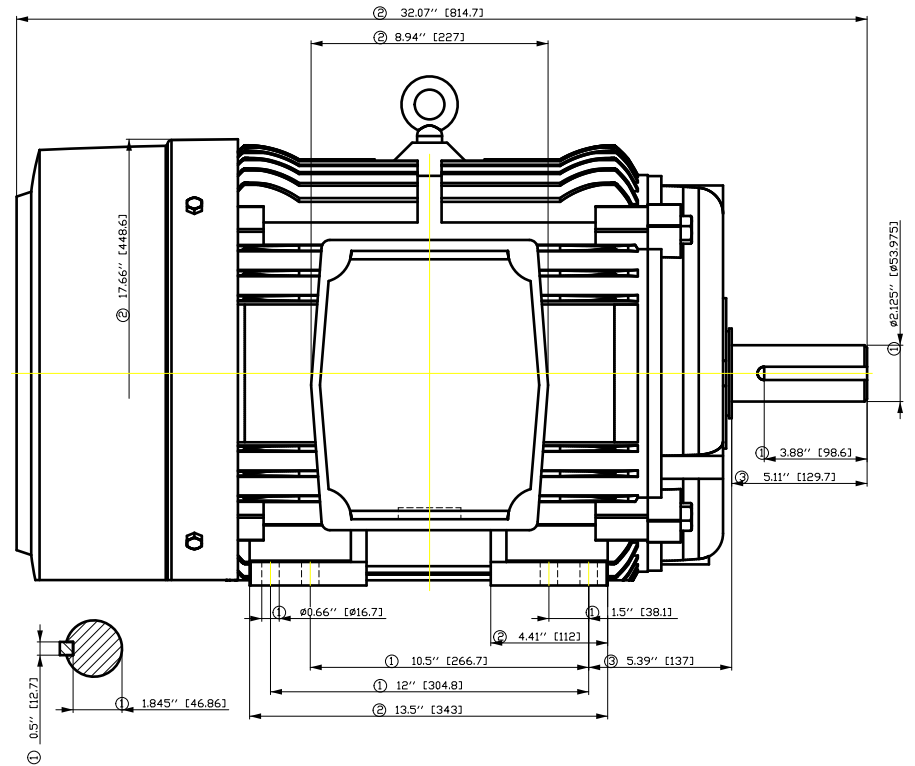

| Tolerance | Surface | Material | Weight | Scale |
|-----------------------|---|---------------------------|------------------------------|------------|
| F50G GF-00FF000H E | Author Creator Approval Department Change Order | ÖS T a : ^ @ } * | E | { { |
| SIEMENS | Doc. State Revision | MLFB Item No Doc No | Doc Type Paper Size | CH |
| © Siemens AG 2018 | Index RS | Ref No E | 1st Language 2nd Language | ^ } a ^ |
| | Project No E | | Sheet | F of F |

SIEMENS INDUSTRY, INC.

HP 20 VOLTS < 600V RPM 900 TYPE SD100 IEEE841
HZ 60 PHASE 3 FRAME 324T NEMA B

TORQUE & CURRENT VS. SPEED

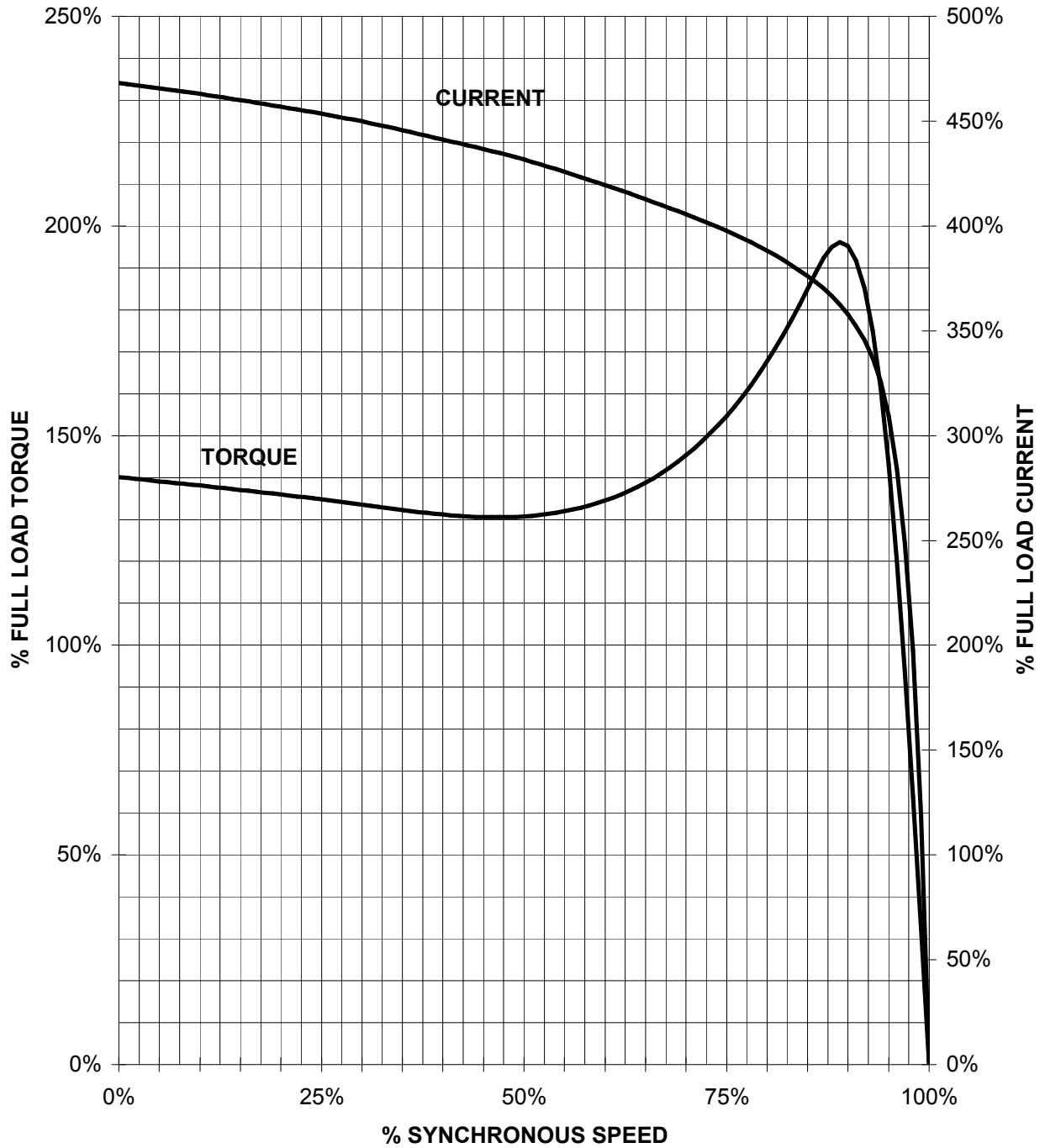

CUSTOMER: _____ ORDER#: _____

20 HP 900 RPM 324T FRAME 460 VOLTS 3 PHASE NEMA DESIGN B

SIEMENS INDUSTRY, INC.
PERFORMANCE CURVE
SD100 IEEE841

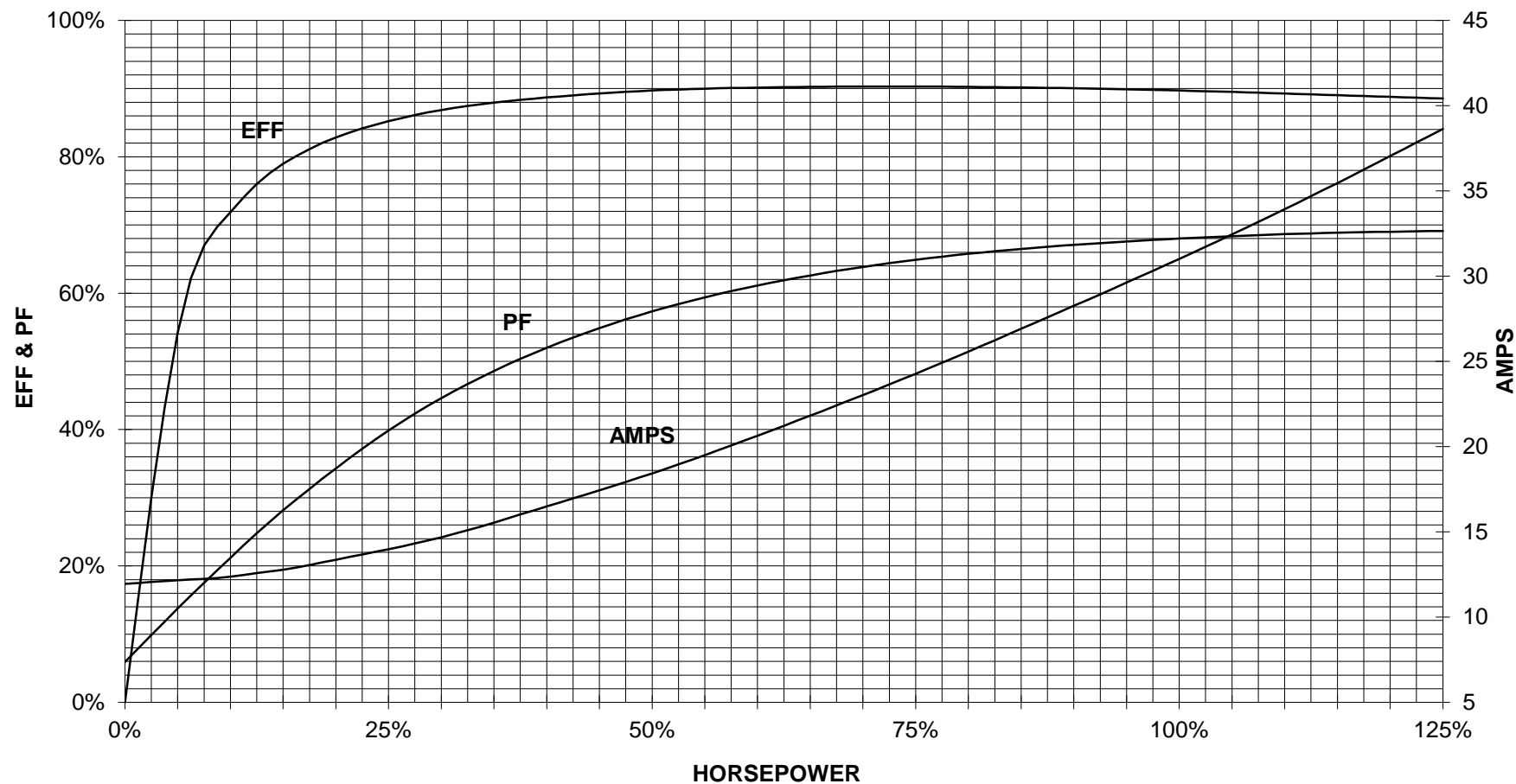

CUSTOMER: _____ ORDER #: _____

PERFORMANCE BASED ON DESIGN CALCULATIONS. SUBJECT TO CHANGE WITHOUT NOTICE.

REV. 1

Main terminal diagram



| 3 LEAD DELTA | | | |
|--------------|----|----|-------|
| LINES | | | CONN. |
| L1 | L2 | L3 | |
| T1 | T2 | T3 | Δ |

responsible dep.
DI MC LVM

technical reference

created by

approved by

Project

SIEMENS

document type
Wiring Diagram

title
1LE2421-3AD11-2AA3

document status
free

document number

customer