

# Data sheet for three-phase Squirrel-Cage-Motors SIMOTICS

Motor type: SD100 IEEE FS: 324TS - 2p - 40 hp -

Client order no.	Item-No.	Offer no.
Order no.	Consignment no.	Project

Remarks

## Electrical data

Class I Division 2 Gr. A, B, C or D, T3

U [V]	$\Delta / Y$	f [Hz]	P [HP]	P [kW]	n [rpm]	I Load [Amps]					LRC	Nom. Eff Load [%]			Pwr. Factor Load [%]			Torque [lb-ft]	T <sub>A</sub> /T <sub>N</sub> LRT [%]	T <sub>k</sub> /T <sub>N</sub> BDT [%]
						4/4	3/4	1/2	0	4/4		3/4	2/4	4/4	3/4	2/4				
460	$\Delta$	60	40.00	30.00	3,600	45.00	34.30	24.90	12.00	290.0	93.6	94.1	94.0	89.0	87.0	80.0	60.0	150	250	

Frame Type: 324TS	Type of constr.: (A) Foot mounted - End shield	Ins. Cl.: Standard Class F Insulation	Motor Prot.: (A) Without Protection	NEMA Des.: B	S.F.: 1.15
Mtr. WT: 539		Temp. Rise Cl.: B	Amb. Temp.: + 40 to -20 °C @1000 m	kVA: G	IP 55

## Mechanical data

Sound level (SPL / SWL) at 60 Hz	77.0 dB(A) / 87.0 dB(A)							Thickener	Polyurea
Octave Band Center Frequencies Hertz								Safe Stall Time Hot	22 s
	250	500	1000	2000	4000	8000	Hz	Safe Stall Time Cold	45 s
SPL@3	56.0	68.0	68.0	70.0	74.0	54.0	dB(A)	Frame material	cast iron
Moment of inertia	3.0 Lb-ft <sup>2</sup>							Color, paint shade	Standard Paint - RAL7030
Ext Load Inertia Capability:	40.0 Lb ft <sup>2</sup>							Coating (paint finish)	Standard Alkyed + Epoxy (C2)
<b>Bearings</b>								<b>Ventilation Type</b>	
Bearing DE   NDE	6312 Z C3 S0			6312 Z C3 S0				Method of cooling	TEFC
Bearing_Type	Ball Bearing			Ball Bearing				Direction of rotation	Bidirectional
AFBMA:	60BC03JP30			60BC03JP30				Fan Material	Polypropylen ESD
<b>Grease</b>								VFD	CT: 4:1 VT: 20:1
Capacity	5.5 oz			5.5 oz				Space heaters	without
Grease Type:	Exxon Mobile EM							Brake:	without

## Terminal box

Lead Wire Connection	3 LEAD - DELTA				Terminal box position	(3) F-1, Standard Floor Mount, T. Box LHS
Voltage	L1	L1	L1	Connected together	Material of terminal box	Cast Iron
----	----	----	----	----	Cable entry	2" NPT
----	T1	T2	T3	----		

## Notes:

I<sub>L</sub>/I<sub>N</sub> = locked rotor current / current nominal  
M<sub>L</sub>/M<sub>N</sub> = locked rotor torque / torque nominal  
M<sub>B</sub>/M<sub>N</sub> = break down torque / nominal torque

3) Value is valid only for DOL operation with motor design IC411  
2) at rated power I at full load

responsible dep. DI MC LVM	technical reference	created by DT Configurator	approved by	<i>Technical data are subject to change! There may be discrepancies between software and hardware versions</i>	
	document type datasheet	document status released	customer		
	title 1LE2421-3BA11-2AA3	document number			
© Siemens AG 2022	rev. 01	creation date 2022-04-08 21:32	language en	Page 1/1	

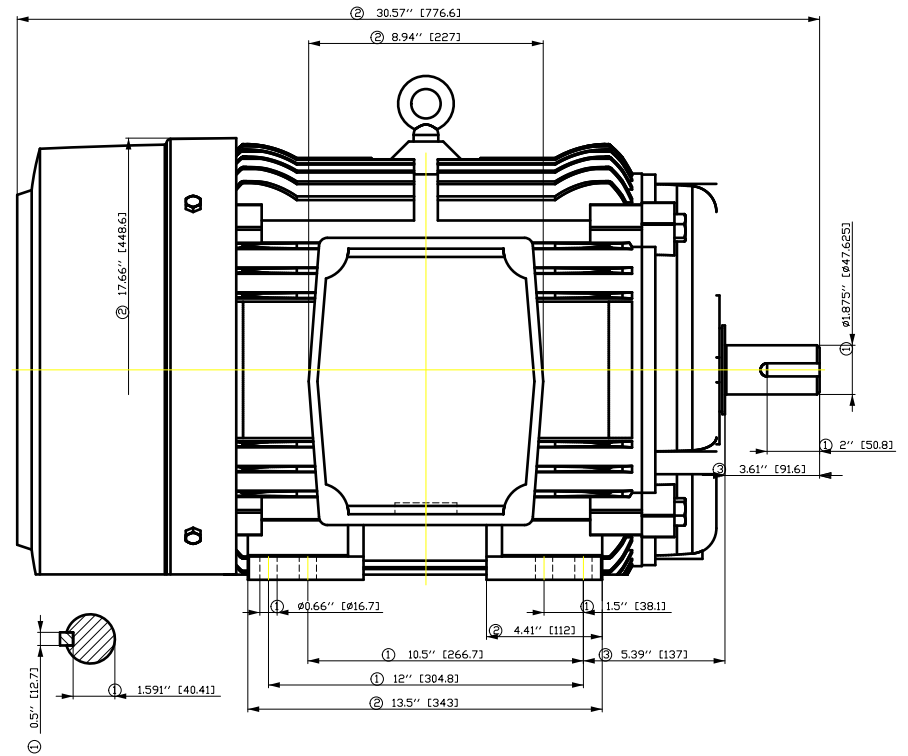
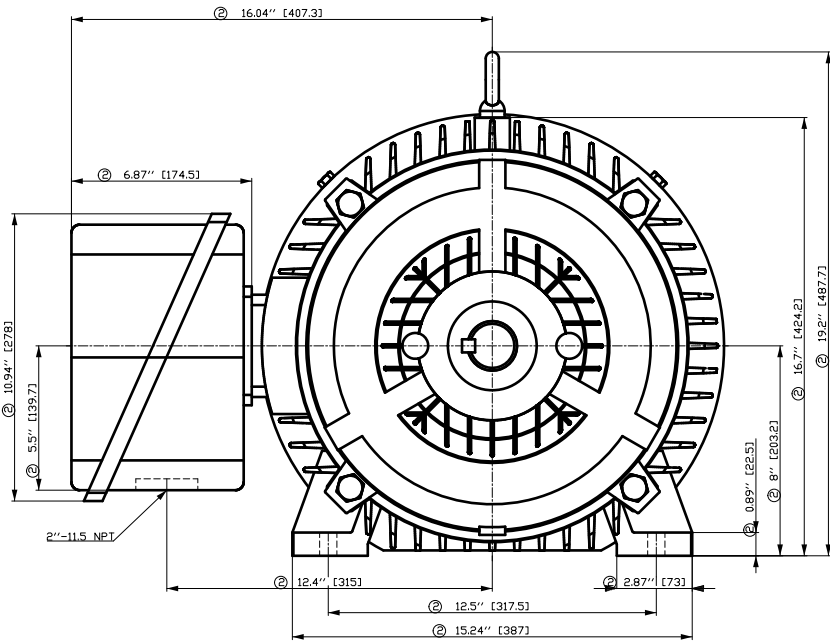

- ① Tolerances according to NEMA std.
- ② All these dimensions corresponding to assemblies and castings shall have a tolerance as per DIN standard 1686-GTB 19.
- ③ Not according to NEMA std.

Tolerance	Surface	Material	Weight	Scale
F50G GF-H00FFB00EH	Author	ÖS	É	{ {
É	Creator	ÖS		
	Approval	T a : ^ @ ~ } *		
	Department			
	Change Order	MFB		Doc Type
<b>SIEMENS</b>	Doc State	I ð B G	Item No	Paper Size CH
© Siemens AG	Revision	Index RS	Doc No	1st Language ^
2018	Project No	É	Ref No	2nd Language á^
				Sheet F of F

# SIEMENS INDUSTRY, INC.

HP 40 VOLTS < 600V RPM 3600 TYPE SD100 IEEE841  
HZ 60 PHASE 3 FRAME 324TS NEMA B

## TORQUE & CURRENT VS. SPEED

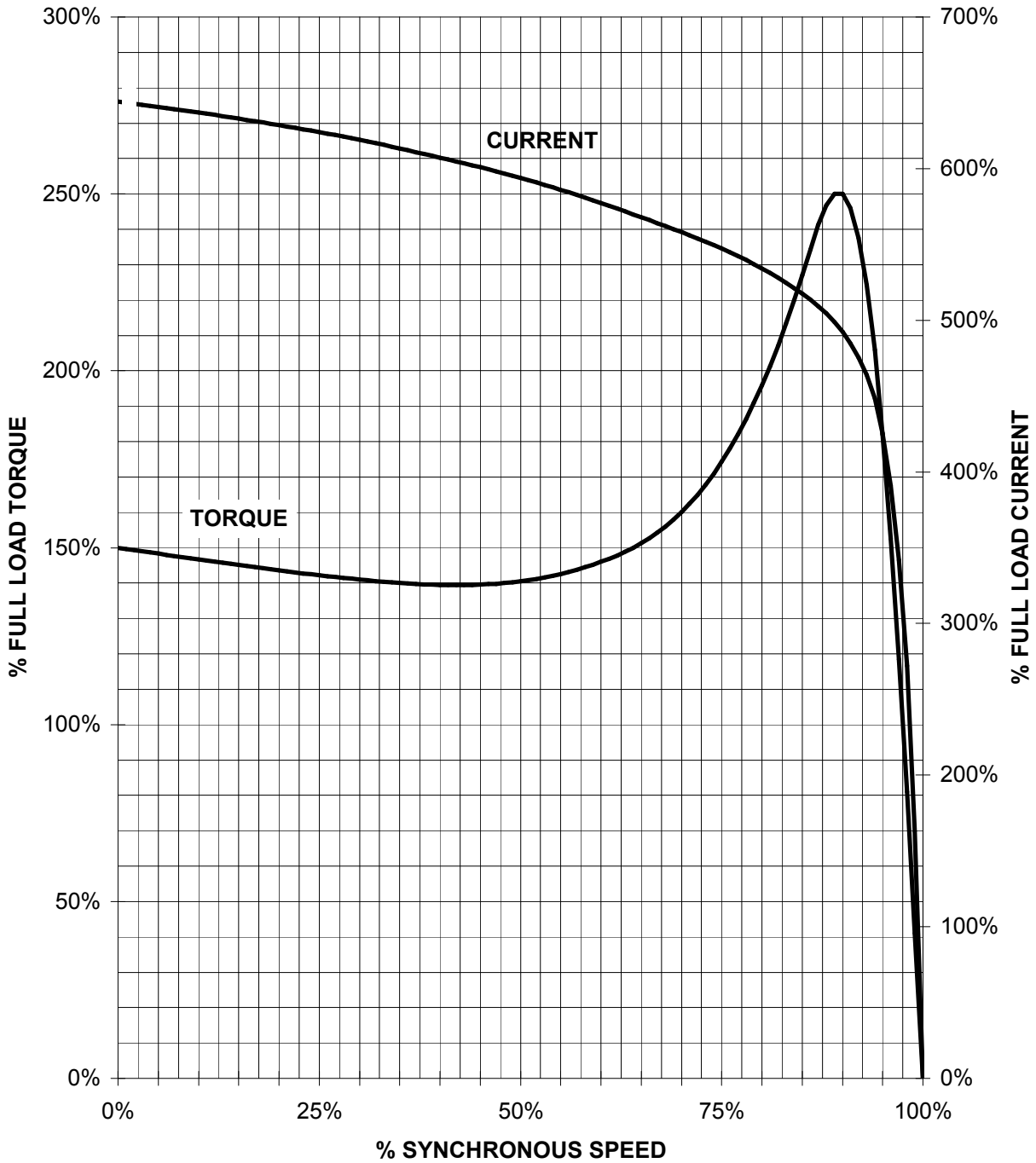

CUSTOMER: \_\_\_\_\_ ORDER#: \_\_\_\_\_

40HP 3600 RPM 324TS FRAME 460 VOLTS 3 PHASE NEMA DESIGN B

**SIEMENS INDUSTRY, INC.**  
**PERFORMANCE CURVE**  
**SD100 IEEE841**

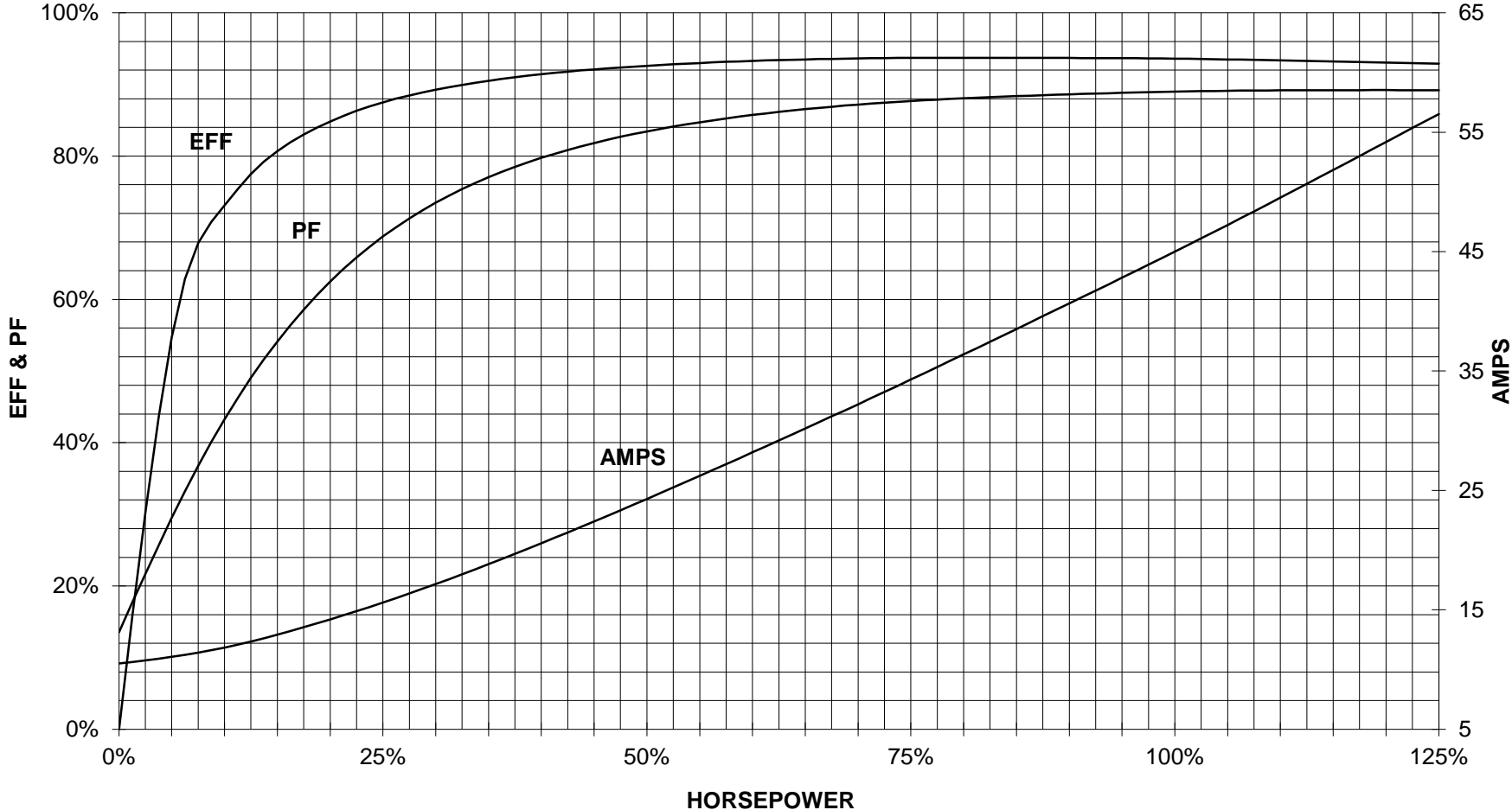

CUSTOMER: \_\_\_\_\_ ORDER \_\_\_\_\_ PO \_\_\_\_\_

PERFORMANCE BASED ON DESIGN CALCULATIONS. SUBJECT TO CHANGE WITHOUT NOTICE.

Main terminal diagram



3 LEAD DELTA			
LINES			CONN.
L1	L2	L3	
T1	T2	T3	Δ

responsible dep. DI MC LVM	technical reference	created by	approved by	Project	
	document type Wiring Diagram		document status free		customer
	title 1LE2421-3BA11-2AA3		document number		
© Siemens AG 2019			rev. 01	creation date 12/03/2019	language Page en 1/1