

Data sheet for three-phase Squirrel-Cage-Motors SIMOTICS

Motor type: SD100 IEEE **FS: 364T - 8p - 30 hp -**

Client order no.	Item-No.	Offer no.
Order no.	Consignment no.	Project
Remarks		

Electrical data

Class I Division 2 Gr. A, B, C or D, T3

U [V]	Δ / Y	f [Hz]	P [HP]	P [kW]	n [rpm]	I Load [Amps]					LRC	Nom. Eff Load [%]			Pwr. Factor Load [%]			Torque [lb-ft]	T _A /T _N LRT [%]	T _k /T _N BDT [%]
						4/4	3/4	1/2	0	4/4		3/4	2/4	4/4	3/4	2/4				
460	Δ	60	30.00	22.00	900	47.00	37.50	31.60	26.00	218.0	91.7	92.0	90.6	65.0	61.0	49.0	178.0	150	200	

Frame Type: 364T	Type of constr.: (A) Foot mounted - End shield	Ins. Cl.: Standard Class F Insulation	Motor Prot.: (A) Without Protection	NEMA Des.: B	S.F.: 1.15
Mtr. WT: 740		Temp. Rise Cl.: B	Amb. Temp.: + 40 to -20 °C @1000 m	kVA: G	IP 55

Mechanical data

Sound level (SPL / SWL) at 60 Hz	60.0 dB(A) / 71.0 dB(A)							Thickener	Polyurea
Octave Band Center Frequencies Hertz									
	250	500	1000	2000	4000	8000	Hz	Safe Stall Time Hot	22 s
SPL@3	48.0	53.0	54.0	53.0	52.0	50.0	dB(A)	Safe Stall Time Cold	40 s
Moment of inertia	0.0 Lb-ft ²							Frame material	cast iron
Ext Load Inertia Capability:	769.0 Lb ft ²							Color, paint shade	Standard Paint - RAL7030
Bearings								Coating (paint finish)	Standard Alkyed + Epoxy (C2)
Bearing DE NDE	6314 Z C3 S0			6314 Z C3 S0			Ventilation Type		
Bearing_Type	Ball Bearing			Ball Bearing			Method of cooling	TEFC	
AFBMA:	70BC03JP30			70BC03JP30			Direction of rotation	Bidirectional	
Grease								Fan Material	Polypropylen ESD
Capacity	7.5 oz			7.5 oz			VFD	CT: 4:1 VT: 20:1	
Grease Type:	Exxon Mobile EM							Space heaters	without
								Brake:	without

Terminal box

Lead Wire Connection	3 LEAD - DELTA				Terminal box position	(3) F-1, Standard Floor Mount, T. Box LHS
Voltage	L1	L1	L1	Connected together	Material of terminal box	Cast Iron
----	----	----	----	----	Cable entry	3" NPT
----	T1	T2	T3	----		

Notes:

I_L/I_N = locked rotor current / current nominal
M_L/M_N = locked rotor torque / torque nominal
M_B/M_N = break down torque / nominal torque

3) Value is valid only for DOL operation with motor design IC411
2) at rated power / at full load

responsible dep. DI MC LVM	technical reference	created by DT Configurator	approved by	<i>Technical data are subject to change! There may be discrepancies between software and hardware versions</i>	
	document type datasheet	document status released	customer		
	title 1LE2421-3CD11-2AA3	document number			
© Siemens AG 2022	rev. 01	creation date 2022-04-08 22:10	language en	Page 1/1	

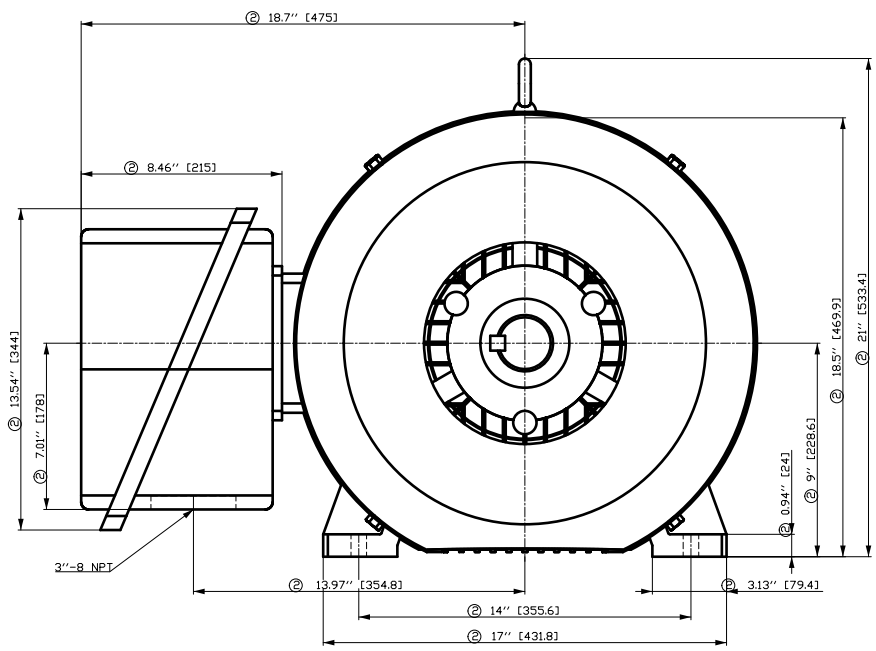

- ① Tolerances according to NEMA std.
- ② All these dimensions corresponding to assemblies and castings shall have a tolerance as per DIN standard 1686-GTB 19.
- ③ Not according to NEMA std.

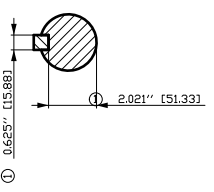
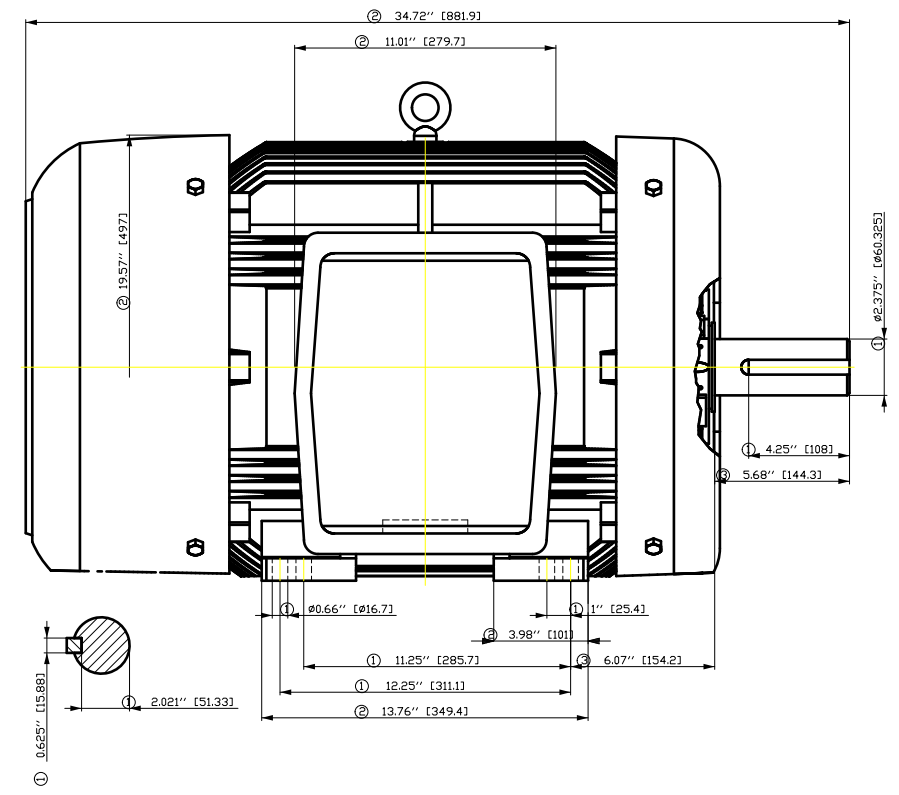

Tolerance	Surface	Material	Weight	Scale
F50G GF-HÖFFER	Author	ÖS T a : ^ & @ } *	È	{ {
È	Creator			
	Approval			
	Department			
	Change Order	MFB	Doc Type	/
SIEMENS	Doc. State	I ð BGG	Item No	Paper Size
	Revision	Index RS	Doc No	1st Language ^
				2nd Language à^
© Siemens AG 2018	Project No	È	Ref No	È
			Sheet	F of F

刀线管
 用转为
 所全
 文
 图
 形
 数
 据
 库
 中
 存
 档
 此
 图
 纸
 为
 数
 据
 库
 中
 存
 档
 的
 图
 纸
 其
 中
 的
 数
 据
 均
 已
 存
 档
 如
 有
 更
 改
 请
 与
 数
 据
 库
 管
 理
 人
 员
 联
 系
 此
 图
 纸
 为
 数
 据
 库
 中
 存
 档
 的
 图
 纸
 其
 中
 的
 数
 据
 均
 已
 存
 档
 如
 有
 更
 改
 请
 与
 数
 据
 库
 管
 理
 人
 员
 联
 系
 此
 图
 纸
 为
 数
 据
 库
 中
 存
 档
 的
 图
 纸
 其
 中
 的
 数
 据
 均
 已
 存
 档
 如
 有
 更
 改
 请
 与
 数
 据
 库
 管
 理
 人
 员
 联
 系

SIEMENS INDUSTRY, INC.

HP 30 VOLTS < 600V RPM 900 TYPE SD100 IEEE841
HZ 60 PHASE 3 FRAME 364T NEMA B

TORQUE & CURRENT VS. SPEED

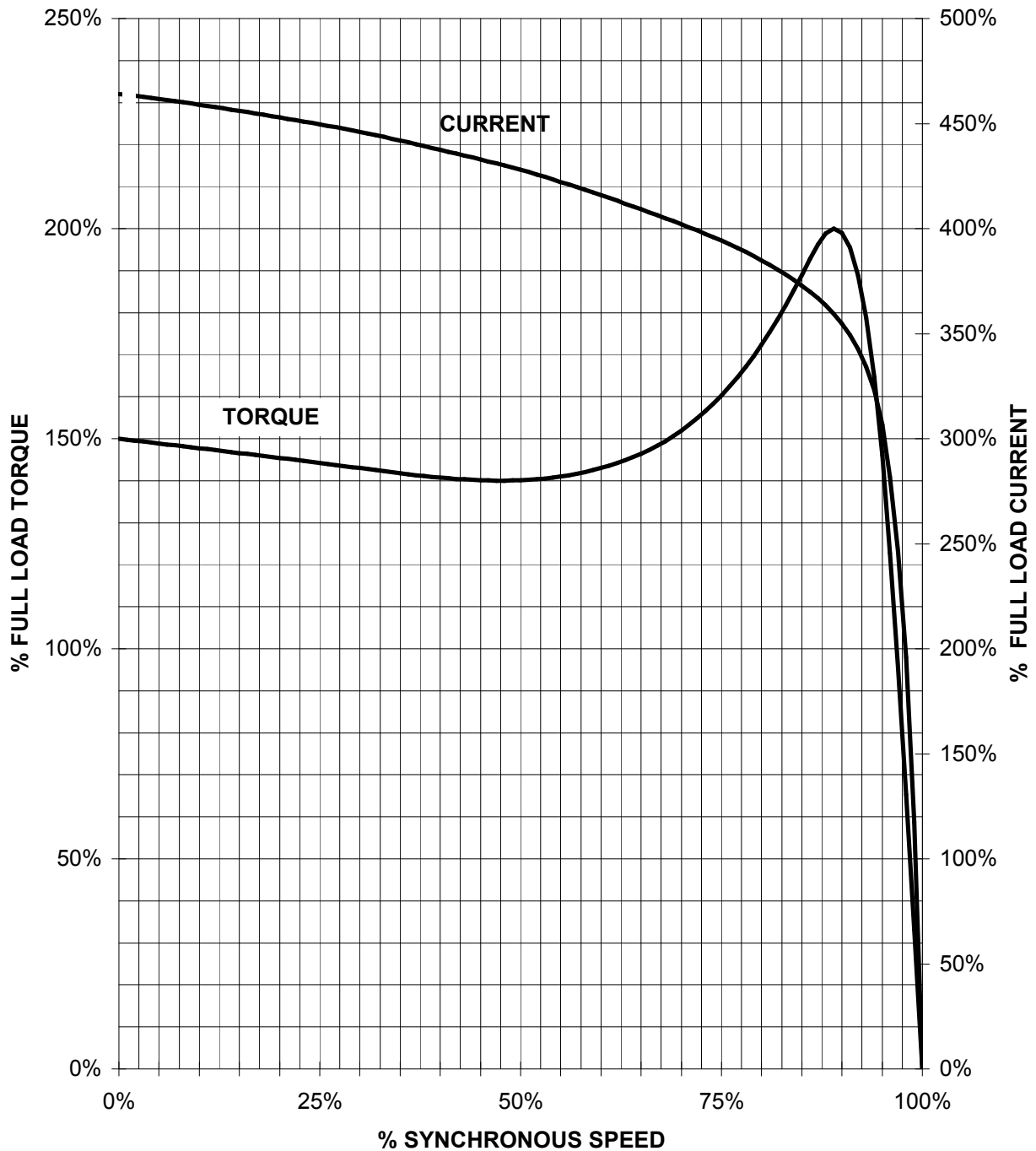

CUSTOMER: _____ ORDER#: _____

30 HP 900 RPM 364T FRAME 460 VOLTS 3 PHASE NEMA DESIGN B

SIEMENS INDUSTRY, INC.
PERFORMANCE CURVE
SD100 IEEE841

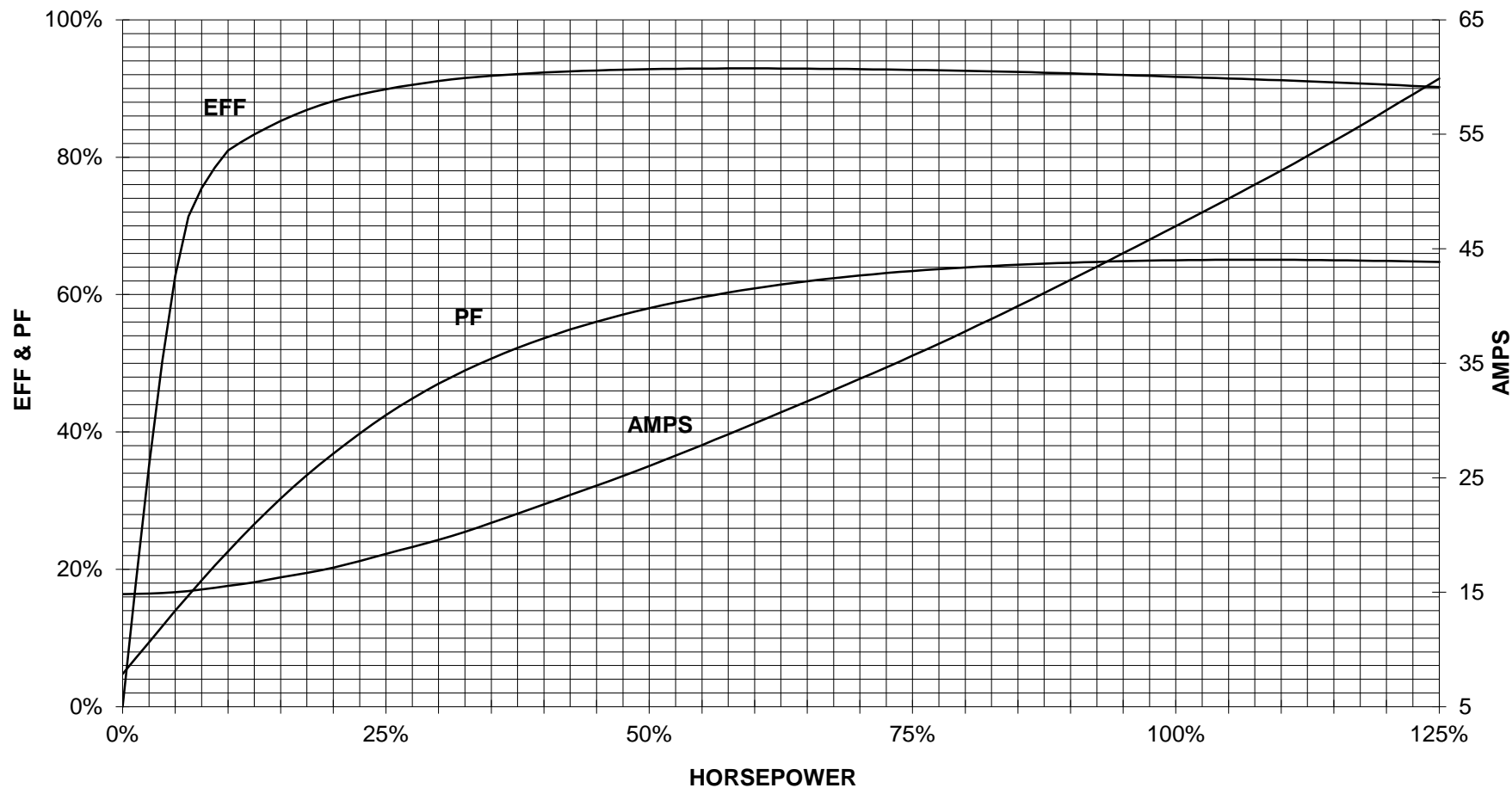

CUSTOMER _____ ORDER # _____ PO # _____

PERFORMANCE BASED ON DESIGN CALCULATIONS. SUBJECT TO CHANGE WITHOUT NOTICE.

REV. 1

Main terminal diagram

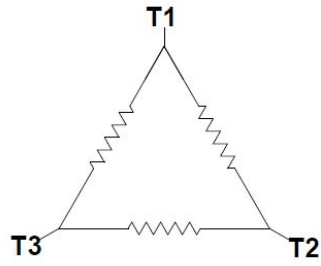

3 LEAD DELTA			
LINES			CONN.
L1	L2	L3	
T1	T2	T3	Δ

responsible dep. DI MC LVM	technical reference	created by	approved by	Project		
	document type Wiring Diagram		document status free		customer	
	title 1LE2421-3CD11-2AA3		document number			
© Siemens AG 2019			rev. 01	creation date 12/03/2019	language en	Page 1/1