

Data sheet for three-phase Squirrel-Cage-Motors SIMOTICS

Motor type: SD100 IEEE FS: 365TS - 2p - 75 hp -

Client order no.	Item-No.	Offer no.
Order no.	Consignment no.	Project
Remarks		

Electrical data

Class I Division 2 Gr. A, B, C or D, T3

U [V]	Δ / Y	f [Hz]	P [HP]	P [kW]	n [rpm]	I Load [Amps]					LRC	Nom. Eff Load [%]			Pwr. Factor Load [%]			Torque [lb-ft]	T _A /T _N LRT [%]	T _k /T _N BDT [%]
						4/4	3/4	1/2	0	4/4		3/4	2/4	4/4	3/4	2/4				
460	Δ	60	75.00	55.00	3,600	86.00	64.90	46.30	22.00	543.0	94.1	94.3	93.7	88.0	86.0	81.0	111.0	160	260	
Frame Type: 365TS		Type of constr.: (A) Foot mounted - End shield				Ins. Cl.: Standard Class F Insulation		Motor Prot.: (A) Without Protection			NEMA Des.: B		S.F.: 1.15							
Mtr. WT: 817						Temp. Rise Cl.: B		Amb. Temp.: + 40 to -20 °C @1000 m			kVA: G		IP 55							

Mechanical data

Sound level (SPL / SWL) at 60 Hz	81.0 dB(A) / 91.0 dB(A)		Thickener	Polyurea					
Octave Band Center Frequencies Hertz			Safe Stall Time Hot	16 s					
250	500	1000	2000	4000	8000	Hz	Safe Stall Time Cold	27 s	
SPL@3	65.0	76.0	75.0	76.0	66.0	59.0	dB(A)	Frame material	cast iron
Moment of inertia	5.8 Lb-ft ²		Color, paint shade	Standard Paint - RAL7030					
Ext Load Inertia Capability:	71.0 Lb ft ²		Coating (paint finish)	Standard Alkyed + Epoxy (C2)					
Bearings			Ventilation Type						
Bearing DE NDE	6314 Z C3 S0		6314 Z C3 S0						
Bearing_Type	Ball Bearing		Ball Bearing						
AFBMA:	70BC03JP30		70BC03JP30						
Grease			Method of cooling						
Capacity	7.5 oz		7.5 oz						
Grease Type:	Exxon Mobile EM		Direction of rotation						
			Fan Material						
			VFD						
			Space heaters						
			Brake:						

Terminal box

Lead Wire Connection		3 LEAD - DELTA			Terminal box position	(3) F-1, Standard Floor Mount, T. Box LHS
Voltage	L1	L1	L1	Connected together	Material of terminal box	Cast Iron
----	----	----	----	----	Cable entry	3" NPT
----	T1	T2	T3	----		

Notes:

I_L/I_N = locked rotor current / current nominal
M_L/M_N = locked rotor torque / torque nominal
M_B/M_N = break down torque / nominal torque

3) Value is valid only for DOL operation with motor design IC411
2) at rated power / at full load

responsible dep. DI MC LVM	technical reference	created by DT Configurator	approved by	<i>Technical data are subject to change! There may be discrepancies between software and hardware versions</i>	
	document type datasheet	document status released		customer	
	title 1LE2421-3DA21-2AA3	document number			
© Siemens AG 2022	rev. 01	creation date 2022-04-08 22:13	language en	Page 1/1	

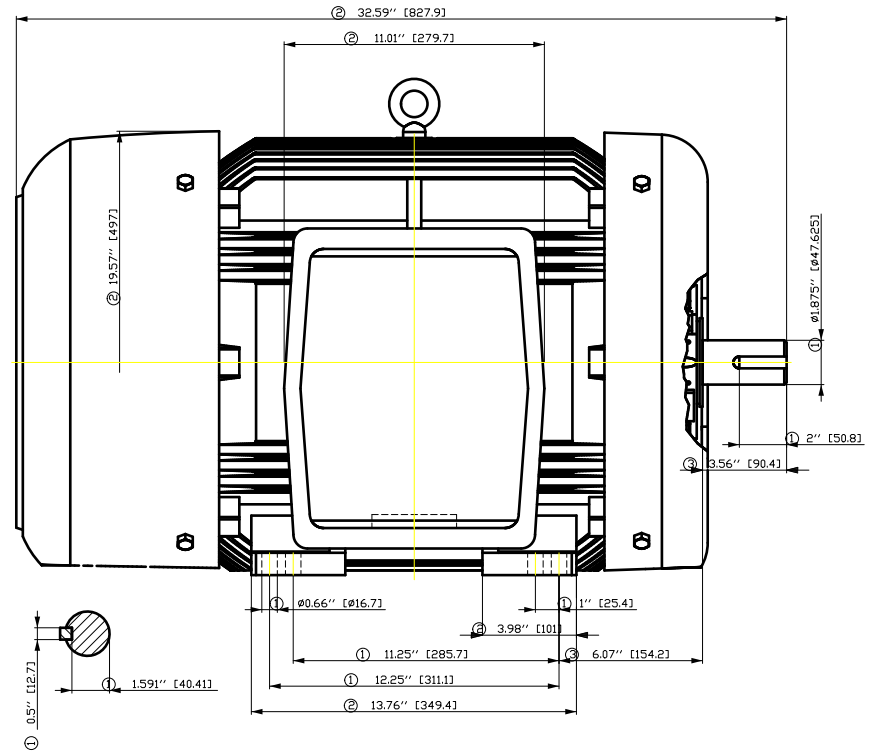
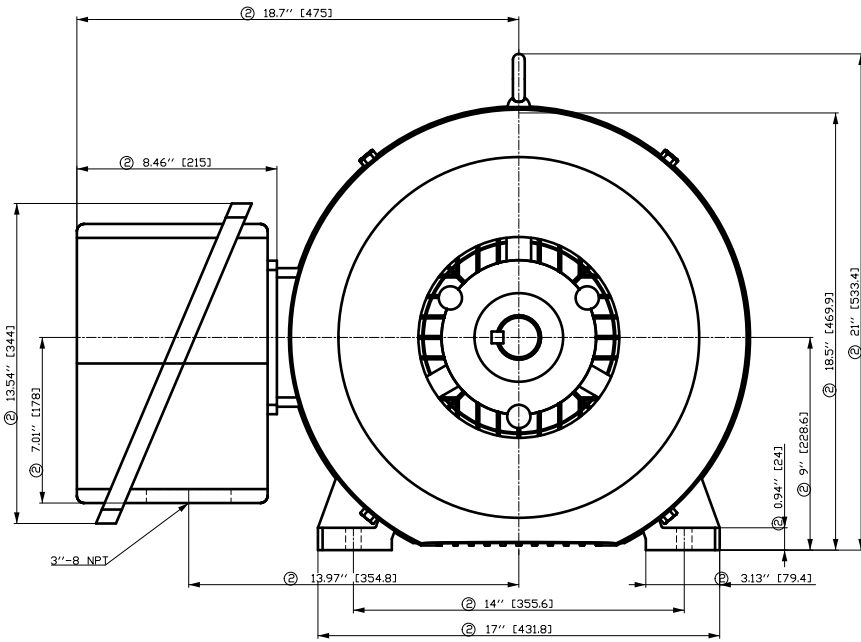

- ① Tolerances according to NEMA std.
- ② All these dimensions corresponding to assemblies and castings shall have a tolerance as per DIN standard 1686-GTB 19.
- ③ Not according to NEMA std.

Tolerance	Surface	Material	Weight	Scale
F50G GF-H00G F300H E	Author Creator Approval Department Change Order	ÖS T æ : ^ & @ ~ } *	E	{ {
SIEMENS	Doc. State	Item No	Doc Type	Paper Size
	Revision	Index	Doc No	1st Language 2nd Language
© Siemens AG 2018	Project No	Ref No	Sheet	F of F

SIEMENS INDUSTRY, INC.

HP 75 VOLTS < 600V RPM 3600 TYPE SD100 IEEE841
HZ 60 PHASE 3 FRAME 365TS NEMA B

TORQUE & CURRENT VS. SPEED

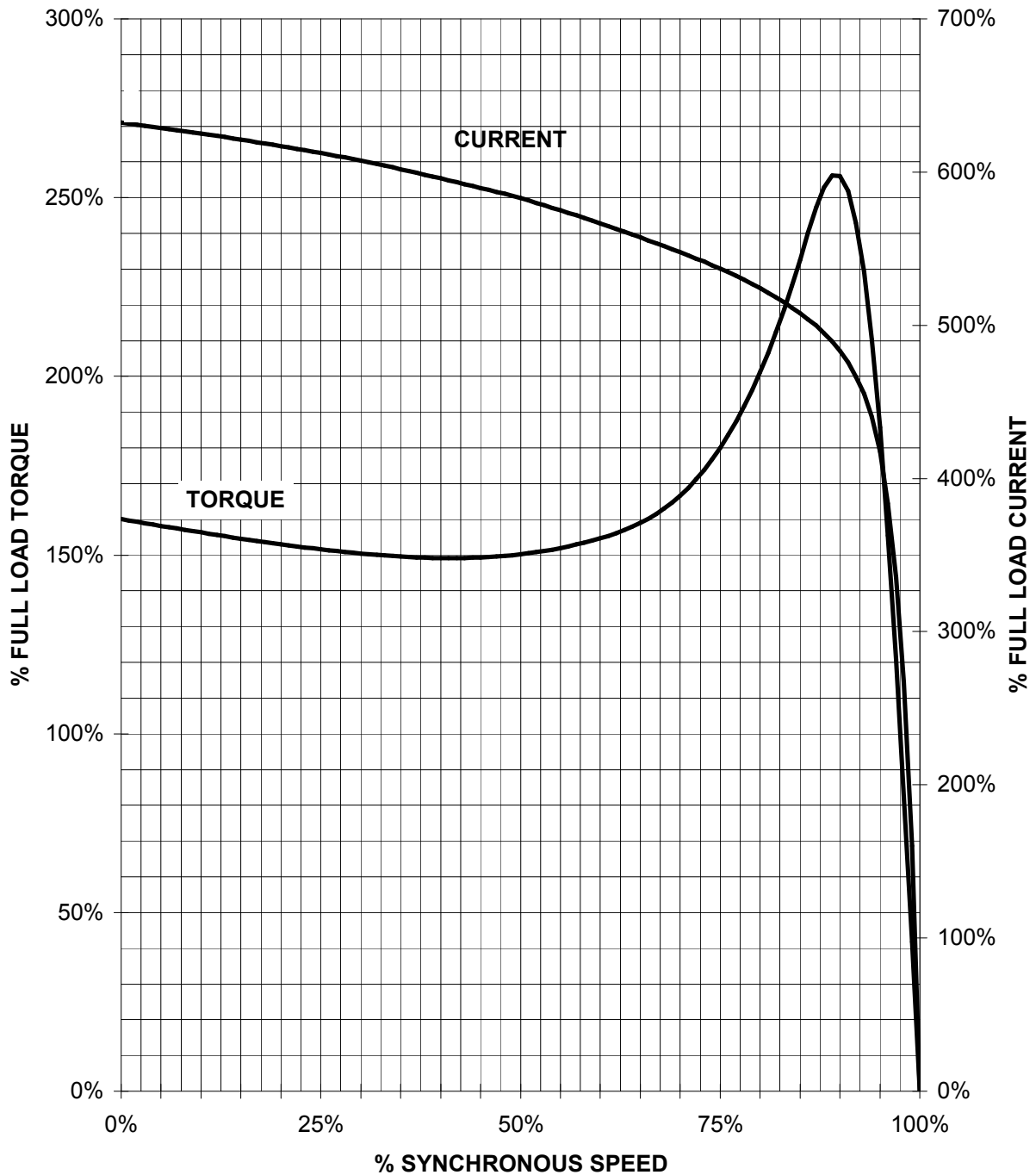

CUSTOMER: _____ ORDER#: _____

75 HP 3600 RPM 365TS FRAME 460 VOLTS 3 PHASE NEMA DESIGN B

SIEMENS INDSTRY, INC.
PERFORMANCE CURVE
SD100 IEEE841

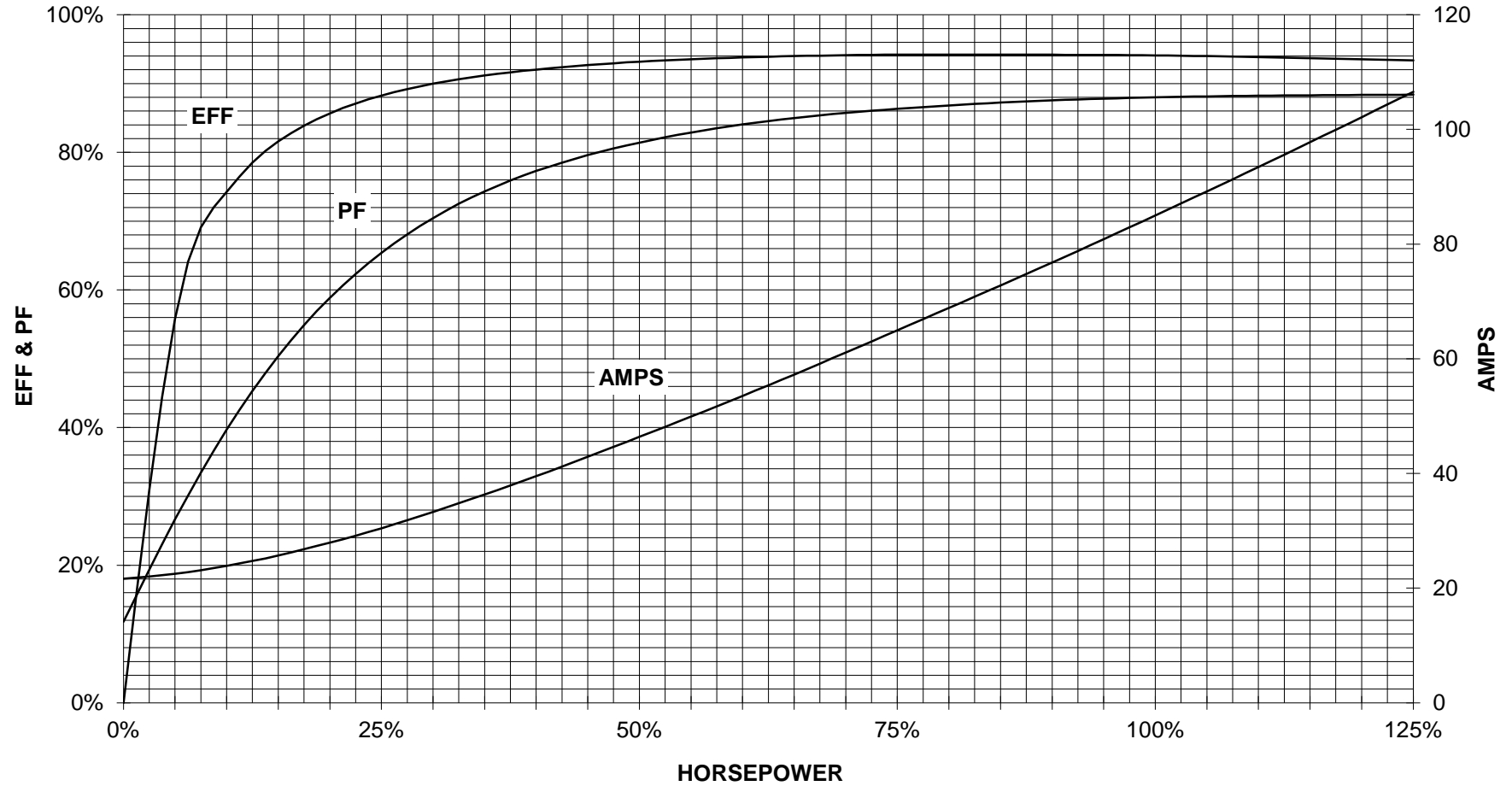

CUSTOMER _____ ORDER # _____ PO # _____

PERFORMANCE BASED ON DESIGN CALCULATIONS. SUBJECT TO CHANGE WITHOUT NOTICE.

REV. 1

Main terminal diagram

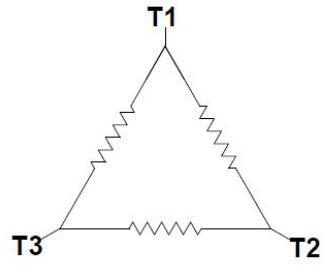

3 LEAD DELTA			
LINES			CONN.
L1	L2	L3	
T1	T2	T3	Δ

responsible dep. DI MC LVM	technical reference	created by	approved by	Project
SIEMENS	document type Wiring Diagram	document status free		customer
	title 1LE2421-3DA21-2AA3	document number		
© Siemens AG 2019		rev. 01	creation date 12/03/2019	language en Page 1/1