

Data sheet for three-phase Squirrel-Cage-Motors SIMOTICS

Motor type: SD100 IEEE FS: 404T - 8p - 50 hp -

Client order no.	Item-No.	Offer no.
Order no.	Consignment no.	Project
Remarks		

Electrical data

Class I Division 2 Gr. A, B, C or D, T3

U [V]	Δ / Y	f [Hz]	P [HP]	P [kW]	n [rpm]	I Load [Amps]					LRC	Nom. Eff Load [%]			Pwr. Factor Load [%]			Torque [lb-ft]	T _A /T _N LRT [%]	T _k /T _N BDT [%]
						4/4	3/4	1/2	0	4/4		3/4	2/4	4/4	3/4	2/4				
460	Δ	60	50.00	37.00	900	67.00	51.70	39.30	28.00	363.0	92.4	93.1	93.0	76.0	73.0	64.0	297.0	140	200	
Frame Type: 404T		Type of constr.: (A) Foot mounted - End shield				Ins. Cl.: Standard Class F Insulation		Motor Prot.: (A) Without Protection			NEMA Des.: B		S.F.: 1.15							
Mtr. WT: 1,116						Temp. Rise Cl.: B		Amb. Temp.: + 40 to -20 °C @1000 m			kVA: G		IP 55							

Mechanical data

Sound level (SPL / SWL) at 60 Hz	66.0 dB(A) / 77.0 dB(A)							Thickener	Polyurea
Octave Band Center Frequencies Hertz								Safe Stall Time Hot	25 s
	250	500	1000	2000	4000	8000	Hz	Safe Stall Time Cold	40 s
SPL@3	58.0	61.0	62.0	57.0	48.0	39.0	dB(A)	Frame material	cast iron
Moment of inertia	0.0 Lb-ft ²							Color, paint shade	Standard Paint - RAL7030
Ext Load Inertia Capability:	124.0 Lb ft ²							Coating (paint finish)	Standard Alkyed + Epoxy (C2)
Bearings								Ventilation Type	
Bearing DE NDE	6316 Z C3 S0			6316 Z C3 S0			Method of cooling	TEFC	
Bearing_Type	Ball Bearing			Ball Bearing			Direction of rotation	Bidirectional	
AFBMA:	80BC03JP30			80BC03JP30			Fan Material	Polypropylen ESD	
Grease								VFD	CT: 4:1 VT: 20:1
Capacity	7.5 oz			7.5 oz			Space heaters	without	
Grease Type:	Exxon Mobile EM							Brake:	without

Terminal box

Lead Wire Connection				3 LEAD - DELTA		Terminal box position	(3) F-1, Standard Floor Mount, T. Box LHS	
Voltage	L1	L1	L1	Connected together		Material of terminal box	Cast Iron	
----	----	----	----	----		Cable entry	3" NPT	
----	T1	T2	T3	----				

Notes:

I_L/I_N = locked rotor current / current nominal
M_L/M_N = locked rotor torque / torque nominal
M_B/M_N = break down torque / nominal torque

3) Value is valid only for DOL operation with motor design IC411
2) at rated power I at full load

responsible dep. DI MC LVM	technical reference	created by DT Configurator	approved by	<i>Technical data are subject to change! There may be discrepancies between software and hardware versions</i>			
	document type datasheet	document status released		customer			
	title 1LE2421-4AD11-2AA3	document number					
© Siemens AG 2022	rev. 01	creation date 2022-04-08 22:41	language en	Page 1/1			

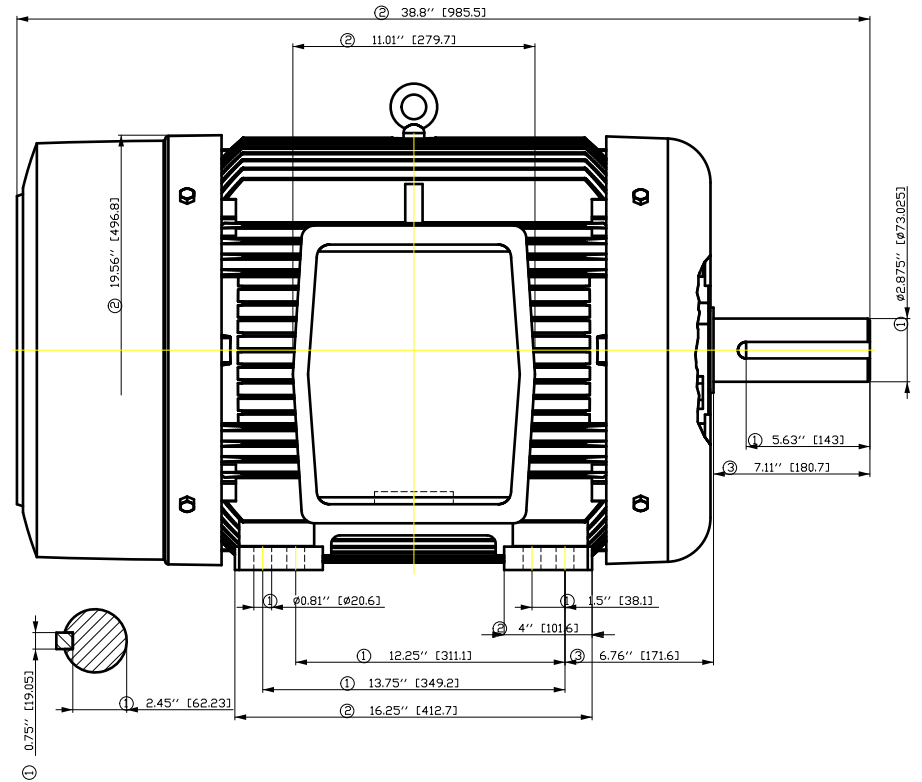
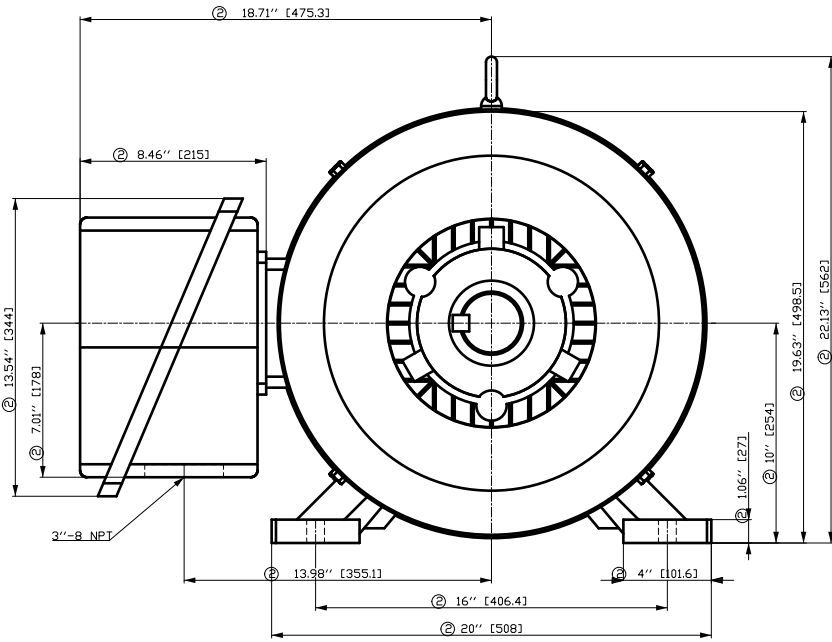

- ① Tolerances according to NEMA std.
- ② All these dimensions corresponding to assemblies and castings shall have a tolerance as per DIN standard 1686-GTB 19.
- ③ Not according to NEMA std.

Tolerance	Surface	Material	Weight	Scale
F50G GF8 COEFF300H E	Author Creator Approval Department Change Order	ÖVS T a : ^ & @ } *	E	{ {
SIEMENS	Doc. State	I B B G	MFB	Doc Type
	Revision	Index RS	Item No	Paper Size CH
© Siemens AG 2018	Project No	E	Doc No	1st Language ^ 2nd Language a^
			Ref No	E
				Sheet F of F

SIEMENS INDUSTRY, INC.

HP 50 VOLTS < 600V RPM 900 TYPE SD100 IEEE841
HZ 60 PHASE 3 FRAME 404T NEMA B

TORQUE & CURRENT VS. SPEED

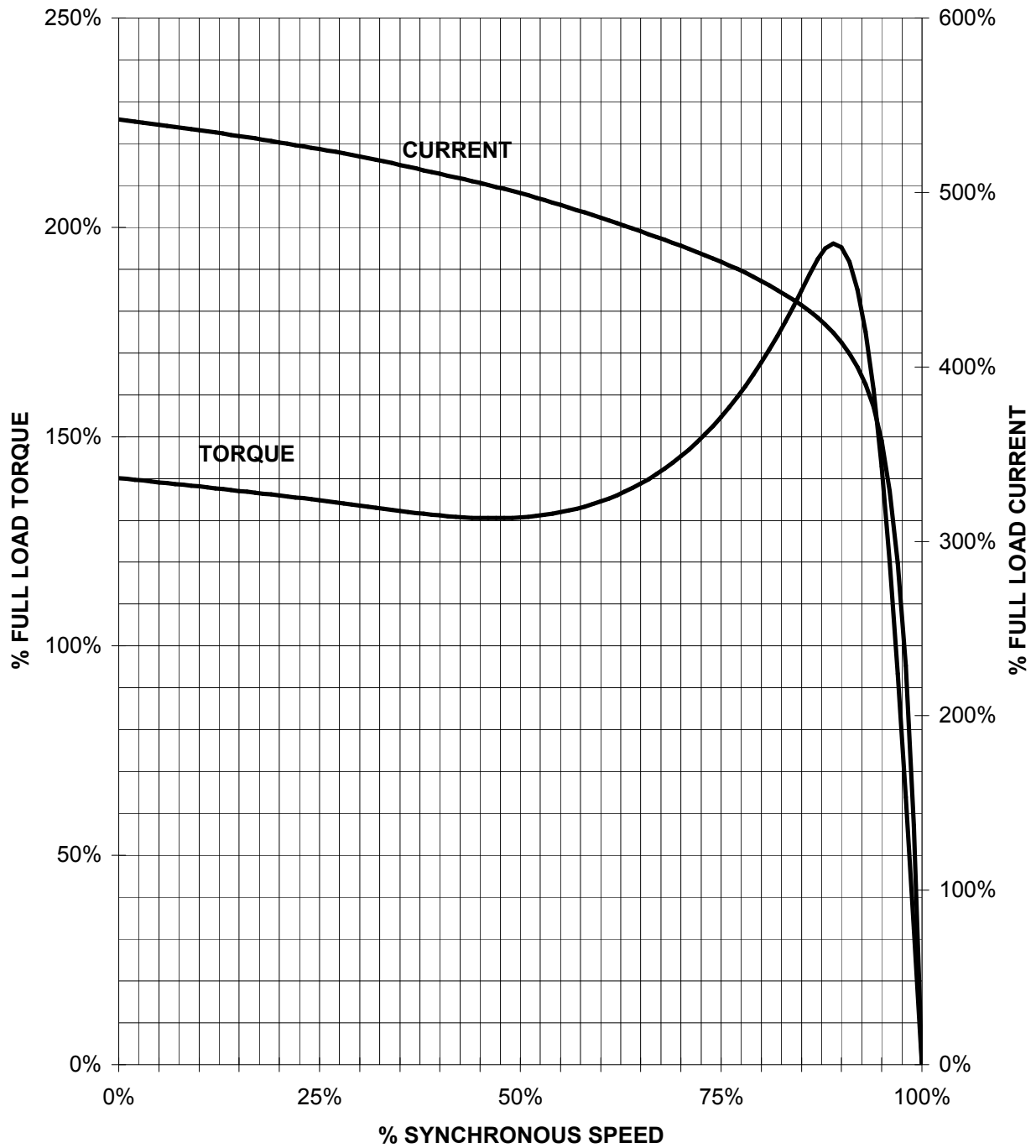

CUSTOMER: _____ ORDER#: _____

50 HP 900 RPM 404T FRAME 460 VOLTS 3 PHASE NEMA DESIGN B

SIEMENS INDUSTRY, INC.
PERFORMANCE CURVE
SD100 IEEE841

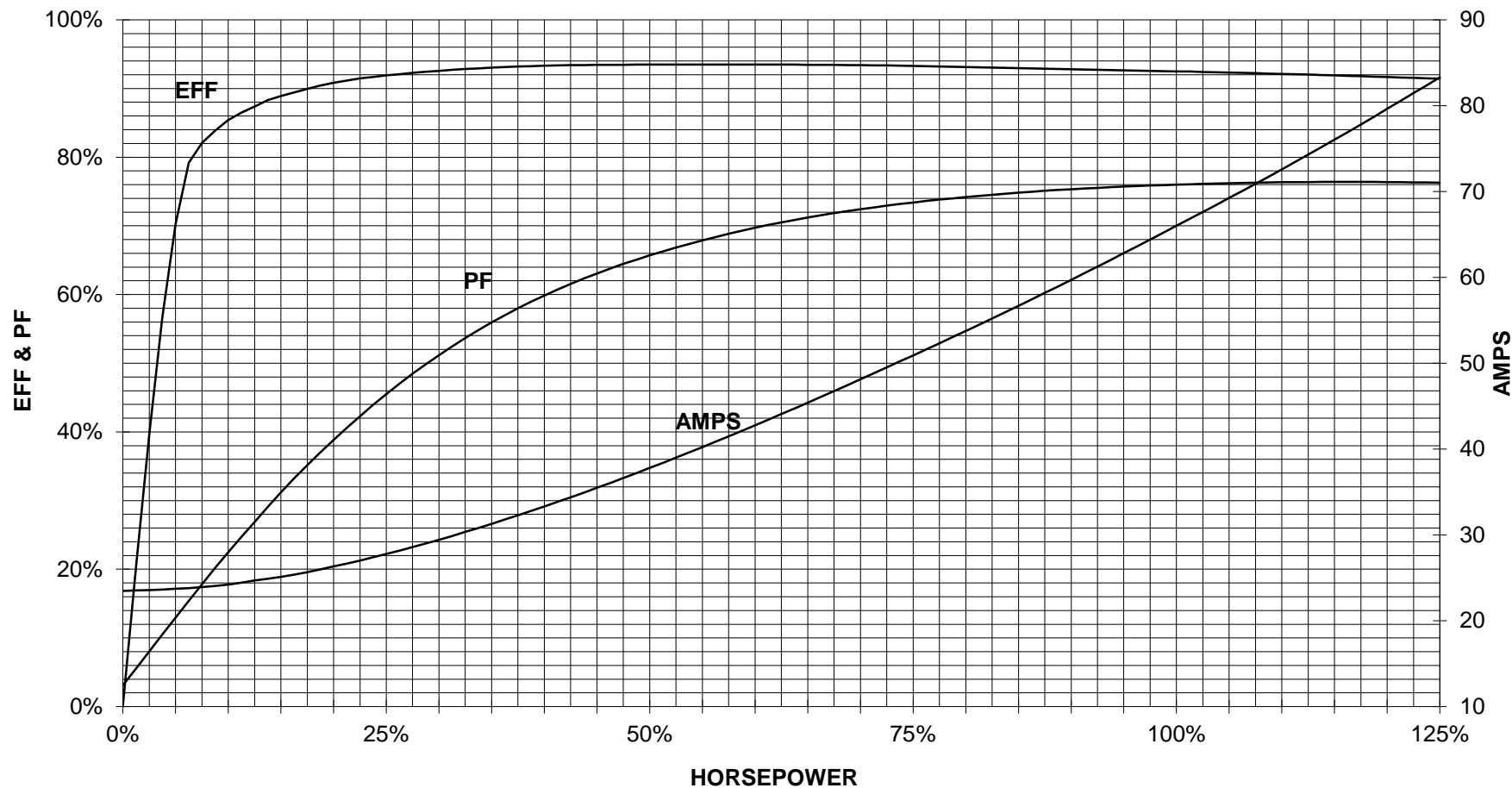

CUSTOMER _____ ORDER # _____ PO # _____

PERFORMANCE BASED ON DESIGN CALCULATIONS. SUBJECT TO CHANGE WITHOUT NOTICE.

REV. 1

Main terminal diagram

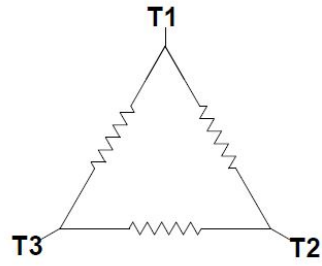

3 LEAD DELTA			
LINES			CONN.
L1	L2	L3	
T1	T2	T3	Δ

responsible dep. DI MC LVM	technical reference	created by	approved by	Project			
	document type Wiring Diagram			document status free		customer	
	title 1LE2421-4AD11-2AA3			document number			
© Siemens AG 2019				rev. 01	creation date 12/03/2019	language en	Page 1/1